

**Maintenance Library**

**Tools and Test Equipment  
Volume 2  
Parts Catalog**

## PREFACE

This Parts Catalog (PC) contains listings and illustrations of all replaceable assemblies, subassemblies and detail parts released to Production Control on or before September 1, 1972, for the Tools and Test Equipment, Volume 2.

This Tools and Test Equipment, Volume 2, Parts Catalog revision, Form S123-0438-3, obsoletes the previous level edition, Form S123-0438-2 and TNL SS26-3038.

Requests for copies of IBM publications should be made to your IBM representative or to the IBM branch office serving your locality.

This manual has been prepared by the IBM System Development Division, Publications Center, Dept. E01, P.O. Box 12275, Research Triangle Park, North Carolina 27709.

A form is provided at the back of this publication for reader's comments. If the form has been removed, comments may be sent to the above address.

HOW TO USE A PARTS CATALOG . . . . .		ii	<u>Figure</u>		<u>Page</u>
<u>Figure</u>		<u>Page</u>			
1	454105	Dynamic Timer Power Pac Assembly . . . . .	1	22	452400 I/O Tester . . . . . 45
2	453048	Adapter Tool Probe Assembly . . . . .	3	23	5708955 I/O Tester Power Supply . . . . . 47
3	210860	Portable Power Supply Assembly . . . . .	4	24	2200012 C. E. Box Assembly 2311/2314 . . . . . 49
4	477280	Power Supply Assembly . . . . .	6	25	2200014 Indicator Box Assembly . . . . . 51
5	724830	Remote Recycle Control Assembly . . . . .	9	26	5052684 C. E. Box Assembly 1070 . . . . . 53
6	460476	Data Transceiver Signal Simulator . . . . .	12	27	Deleted . . . . . 56
7	338106	CF-22 Pluggable Unit Assembly . . . . .	14	28	821050 C. E. Box Assembly 1440 . . . . . 58
8	261159	TR-5 Trigger Pluggable Unit Assembly . . . . .	15	29	635491 Add Machine Drive Unit . . . . . 61
9	300638	TR-1 Trigger Pluggable Unit Assembly . . . . .	16	30	2156809 C. E. Offline Test Set 1710 . . . . . 63
10	300642	TR-3 Trigger Pluggable Unit Assembly . . . . .	17	31	2108788 C. E. Remote Box Assembly . . . . . 65 1301-2302
11	338904	Front Cover Assembly . . . . .	18	32	727007 C. E. Box Assembly 1620 . . . . . 67
12	338903	Chassis Assembly . . . . .	19	33	822781 1050 C. E. Diagnostic Box Assembly . . . . . 69
13	461142	7330 Tape Tester Assembly . . . . .	21	34	2100937 305 Sync Panel Remote Control Box Assembly . . . . . 71
14	9900385	Offline Selectric Analyzer Assembly . . . . .	24	35	453670 Manual Interface Tester (MIT) . . . . . 72
15	2513300	Field Tester Assembly 2420 . . . . .	25	36	5712439 Marginal Check Control Unit Assembly . . . . . 74
16	1765342	Field Tester Assembly 2420/3420		37	2200054 44RK C. E. Control Box Assembly . . . . . 76
16	461222	7340M1 & 7340M2 Functional Tester . . . . .	27	38	453611 Universal Teleprocessing Testing Assembly . . . . . 77
16	461445	7340M3 Functional Tester . . . . .	27	39	453625 ROS Address Tracer Assembly . . . . . 80
17	452394	Communications System Simulator (2 sheets) . . . . .	30	40	453630 Control Unit Simulator Assembly . . . . . 82
18	822677	Control Panel Assembly . . . . .	34	41	1272825 2740 C. E. Aid Assembly . . . . . 85
19	822678	Chassis Assembly . . . . .	35	42	2200180 2301/2303 C. E. Clock Write Box Assembly . . . . . 87
20	461390	729/7330 Field Tester Assembly . . . . .	36	43	2263591 1512 C. E. Box Assembly . . . . . 89
21	461413	2401 Field Tester Assembly . . . . .	39	44	5495060 Interface Adapter Assembly . . . . . 90
21A	5420330	2400 Tape Unit Tester . . . . .	42	45	453599 Line Interogation Device - DOM 453649 Line Interogation Device - WTC . . . . . 91
				46	453596 New Selectric Tester (NEST) . . . . . 94
					NUMERICAL INDEX . . . . . X-1

## TOOLS AND TEST

### HOW TO USE THIS ILLUSTRATED PARTS CATALOG (IPC)

#### PART I

To find parts quickly, a general understanding of the structure of this catalog is necessary. The catalog is divided into three major sections:

- The Visual Index, containing overall views of the machine, with call-outs pointing to detailed figures.
- The Catalog Section, containing a pictorial breakdown of assemblies and subassemblies.
- The Numerical Index, which is a numerical list of all parts used in the machine, with cross-references to the figure on which the part is found.

#### VISUAL INDEX

The Visual Index, located before the Catalog Section, contains a reduced illustration of every figure in the Catalog Section. The reduced illustrations are tied together with flow arrows to form a natural progression from large assemblies to small assemblies and possibly subassemblies. In effect, a visual table of contents is formed by the Visual Index illustrations.

#### CATALOG SECTION

The Catalog Section contains the full-sized illustrations previously noted in the Visual Index. Index numbers on figures refer to corresponding entries in the Group Assembly Parts List accompanying each figure. Refer to part II for explanation of terms used in the Group Assembly Parts List.

#### NUMERICAL INDEX

The Numerical Index is located after the Catalog Section and contains a complete list, in numerical order, of all part numbers used on the machine. Listed with the part number is the index and figure number on which the part is illustrated. The numerical index makes it possible to locate a part when only the part number is known.

#### STACKED INDEX NUMBERS

Stacked index numbers are used when showing a part and its attaching hardware. The sequence of a typical stack is shown at the right. The circled index number indicates the assembly is broken down within the figure.

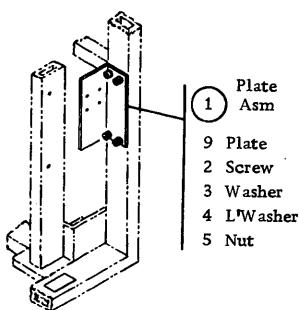

#### ILLUSTRATION NOTES

Cross-reference notes are directly on the illustration. The illustration's next higher assembly reference, normally located in the upper left corner of the page will read: "For Parts Not Shown See Figure X". If an assembly is referenced to a lower level figure, the note located next to the index number will read: "See Figure X."

#### DOUBLE LINED DETAIL BOX

The double lined box differentiates between parts shown on the basic model and parts related to a level and/or feature difference. An explanation of the level or feature difference is given in the double lined box.

#### FINDING A PART

The Visual Index is the starting point for locating a part. The illustrations in the Visual Index are reduced versions of all illustrations in the Catalog Section; therefore, the illustrations can be used to find the assembly containing the desired part. Use references to the detailed figure in the Catalog Section, or to another Visual Index illustration, to determine location of part number.

Once the detailed figure in the catalog section is determined, finding the part on the figure and referring to the listing for the part number and description is all that is required in most cases. If the first catalog section figure referenced shows the assembly containing the required part, the index number for the assembly will reference a lower-level figure where the assembly is broken down to its component parts. If the figure referenced by the Visual Index contains neither the part nor an assembly containing the part, it is then necessary to go to the next higher assembly figure. This figure should then contain the part or an assembly containing the part; if not, an even higher level figure must be used. Refer back to the Visual Index for some other figure that could show the desired part.

Note: Many detailed parts are unavailable, because they are part of an inseparable assembly (two or more parts welded or bonded together), or because they are part of an assembly purchased as a unit. If parts are found on a welded or bonded assembly, the following note follows the description of the assembly: "Assembly components are not replaceable!" If the part is found on a purchased assembly, and the detail parts of this assembly do not have IBM part numbers, the note following the assembly description will read: "Assembly components are not available." In either case, you need to obtain the part number of the assembly, rather than the detailed part.

#### EXAMPLE FOR ORDERING PARTS

			REF
4 -	5726422	FAN ASM-P/S ENCLOSURE FOR NEXT HIGHER ASSEMBLY SEE FIGURE 1-184 FOR ILLUSTRATION SEE FIGURE 4	
- 1	334921	TERMINAL,RING- 18-22 AWG,#6 HOLE,INS	2
- 2	187854	SHIELD,TERMINAL BLOCK- 2 POS	1
- 3	210984	SCREW, RD HD MACH-6-32 X .250 LG	ATT PT 1
- 4	5357050	FAN ASM-NO CONNECTOR	1
- 5	32042	SCREW,MACH BIND. HD 10-32 X .375 LG	ATT PT 2
- 6	5337066	BLADE	1
- 7	5337067	MOTOR 208V/230V 60CY 220V 50CY	1
- 8	130434	SCREW,MACH-SLOTTED HEX HD 10-32 X .375 LG	ATT PT 2
- 9	56079	WASHER,LOCK-EXT T .195ID .410 OD	ATT PT 2
- 10	5726436	HEADER-POWER SUPPLY FAN	1

If the entire fan is required, part number 5726422 should be ordered (all one dot items will be received). If only the subassembly is required, part number 5357050 should be ordered (all two dot items will be received). Each part may be ordered individually.

TOOLS AND TEST

HOW TO USE THIS ILLUSTRATED PARTS CATALOG (IPC)

PART II

- 1) AR  
As Required (AR) in the units per assembly column denotes that the quantity is used as required.
- 2) ATT PT  
Attaching Parts: These parts are used to attach a subassembly to an assembly. The attaching parts are listed immediately following the part to be attached.
- 3) COMM  
Commercial hardware: When this indication appears in the part number column, it denotes hardware procurable from normal commercial sources and not identified by an IBM part number.
- 4) INDENTURE  
The relationship of a part to its next higher assembly is indicated by indentures. For example:  

1	2	3	4
Unit			
•	Assemblies and Detail Parts of Unit		
•	Attaching Parts for Assemblies & Detail Parts		
•	•	Subassemblies	
•	•	Attaching Parts for Subassemblies	
•	•	Detail Parts for Subassemblies, etc.	
- 5) LOZENGE  
The lozenge in the part number column denotes the part is procurable but not recommended for field replacement, and that the next higher assembly should be ordered.
- 6) NP  
The entry NP in the part number column denotes the assembly is non-procurable and the detail parts should be ordered separately.

- 7) NO NO.  
When this indication appears in the part number column, it denotes a group of parts for which no assembly part number has been assigned, and the detail parts should be ordered separately.
- 8) REF  
This entry in the units per assembly column denotes an assembly which is completely assembled on a preceding illustration. Quantities for such items are found in its next higher assembly.
- 9) SIMILAR ASSEMBLIES  
If two assemblies contain a majority of identical parts, they are broken down on the same list. Common parts are shown by one index number. Parts peculiar to one or the other of the assemblies are listed separately and identified by Usable On Code.
- 10) USABLE ON CODE  
Part application and interchangeability is indicated by the usable on code. If this column is blank, the parts pertain to all equipment(s) covered. Two types of codes are used. The alphabetic code denotes similar assemblies and/or features; the numeric code denotes level. Refer to the beginning of each list for the explanation of the code(s).
- 11) SUFFIX CODE  
The suffix code indicates the month (alphabetic) and the year (numeric) of the engineering change which affected interchangeability of the part.

EXAMPLE OF PARTS LIST

LIST AND INDEX NO.	PART NO.	DESCRIPTION				UNITS PER ASM.	USABLE ON CODE
		1	2	3	4		
2-		DRIVE MOTOR ASSEMBLY					
-	2199376 NP	CODE A USED ON 60 CYCLE ONLY CODE B USED ON 50 CYCLE ONLY CODE 1 USED ON ASM PRIOR TO B6 SUFFIX				REF	1A
-	2199386 NP	MOTOR ASM,DRIVE-220 VOLTS 50 CYCLE				REF	1B
- 1	2204176	PULLEY, 60 CYCLE				1	A
- 1	2199255	PULLEY, 50 CYCLE				1	B
- 2	79842	SETSCREW, SPLINE DR CUP PT 8-32 X 3/8 LG				1	
- 3	2204116	MOTOR ASM, 220V AC 60 CYCLE				1	A
- 4	NO NO.	MOTOR ASM, 220V AC 50 CYCLE				1	B
- 5	5526	SCREW, MACH BIND HD 8-32 X 0.625 LG				4	
- 6	2204082	FERRULE, OUTER				1	
- 7	2204033	FERRULE, INNER				1	
- 8	COMM	MOTOR, 1/12 HP-220V 60CPS				1	
- 8	2199258	MOTOR, DRIVE - 220V 50CPS				1	
- 9	2199401	PLATE, MOTOR MT-115/220 VOLTS 60 CYCLE				1	A
- 9	2199402	PLATE, MOTOR MT-220 VOLTS 50 CYCLE				1	B



TOOLS AND TEST

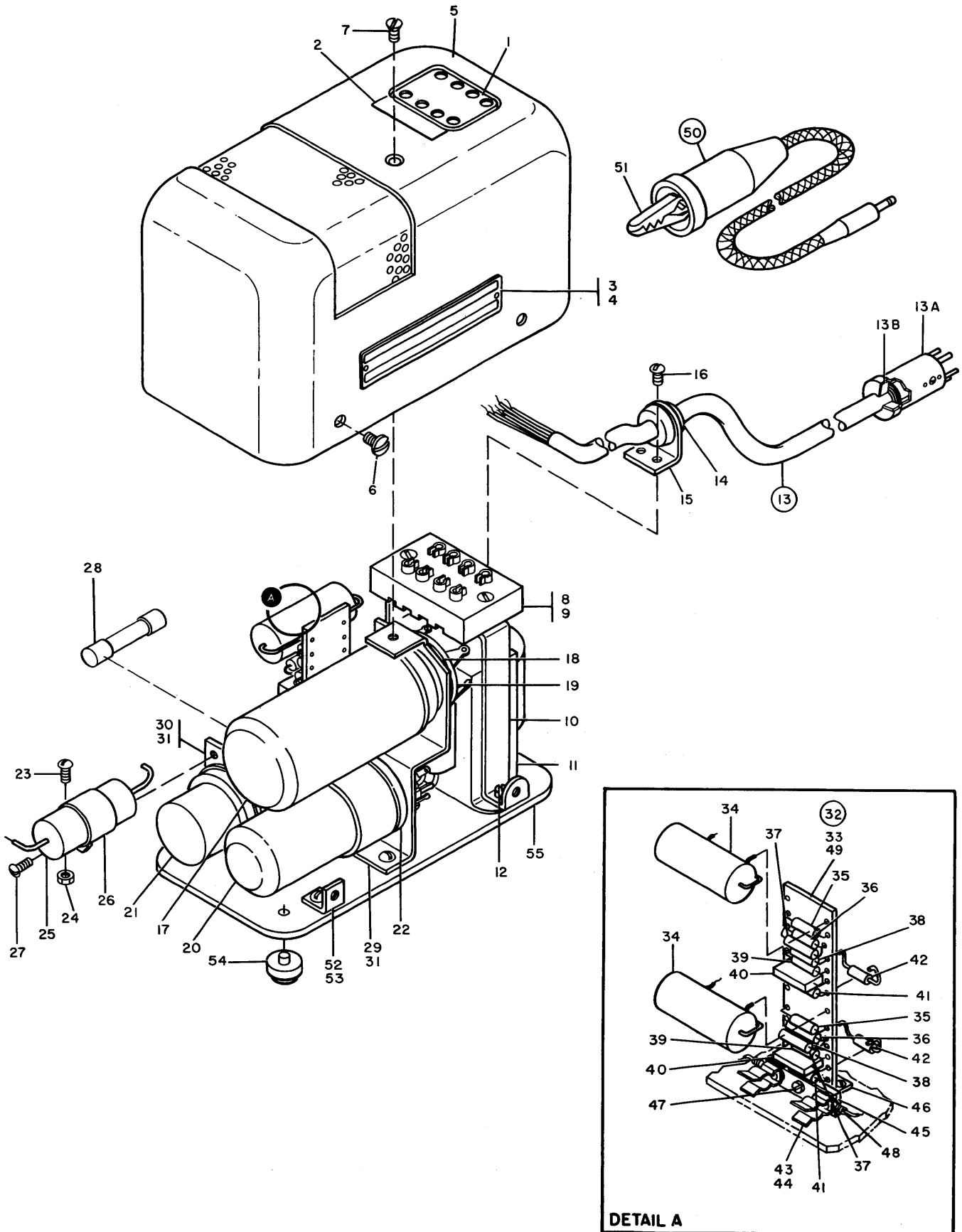

FIGURE 1. DYNAMIC TIMER POWER PAC ASSEMBLY. SEE LIST 1.

TOOLS AND TEST

LIST AND INDEX NUMBER	PART NUMBER	DESCRIPTION	UNITS PER ASM.	USABLE ON CODE
		1 2 3 4		
		DYNAMIC TIMER POWER PAC ASSEMBLY		
1 -	454105	DYNAMIC TIMER POWER PAC ASSEMBLY SEE FIGURE 1 FOR ILLUSTRATION	1	
- 1	451057	. COVER, SAFETY	1	
- 2	221665	. DECAL, PLUG HUB IDENTIFICATION	1	
- 3	186988	. PLATE, VOLTAGE	1	
- 4	105792	. SCREW, SELF-TAPPING	2	ATT PT
- 5	18645C	. CASE	1	
- 6	186636	. SCREW, MACH, BH, 5-40 X 1/8 LG	6	ATT PT
- 7	1668	. SCREW, MACH, FL CSK H, 5-40 X 3/16 LG	1	ATT PT
- 8	237322	. BLOCK, TIMER TERMINAL	1	
- 9	2118	. SCREW, MACH, FL CSK H, 5-40 X 1/2 LG	1	ATT PT
- 10	186442	. BRACKET, MOUNTING, TERMINAL BLOCK	2	
- 11	206589	. TRANSFORMER, 40 VOLT	1	
- 12	92	. SCREW, MACH, RH, 5-40 X 1/4 LG	2	ATT PT
- 13	186478	. CABLE ASSEMBLY, CONNECTOR	1	
- 13A	186460	. . CONNECTOR, CABLE, 6 MALE PRONGS	1	
- 13B	186461	. . BUSHING, CABLE PROTECTIVE	1	
- 14	186722	. GROMMET	1	
- 15	186448	. BRACKET, CABLE MOUNTING	1	
- 16	1413	. SCREW, MACH, RD, 8-32 X 1/4 LG	2	ATT PT
- 17	206916	. VIBRATOR, F1603S	1	
- 18	25757C	. CLIP	1	
- 19	206915	. SOCKET	1	
- 20	206913	. TUBE, 6SL7GT, DHC-TRIODE	1	
- 21	206914	. TUBE, 6H6, DUO HALF WAVE RECTIFIER	1	
- 22	170589	. SOCKET, ELECTRON TUBE-OCTAL	2	
- 23	18491	. SCREW, MACH, RH, 5-40 X 3/16 LG	1	
- 24	7341	. NUT, PLAIN, HEX, 5-40 X 1/4 PL W	1	
- 25	206593	. CAPACITOR, PAPER, 0.47MFD P/M 20% 200VDC	1	
- 26	186446	. BRACKET, CAPACITOR	1	
- 27	103895	. SCREW, MACH, RD HD, 5-40 X 1/8 LG	1	ATT PT
- 28	6325	. FUSE, 1 AMP	1	
- 29	186449	. BRACKET, MOUNTING, AMP AND VIBRATOR	1	
- 30	186444	. BRACKET, RECTIFIER MOUNTING	1	
- 31	38363	. SCREW, MACH, FIL H, 8-32 X 5/32 LG	6	ATT PT
- 32	186530 NP	. PANEL ASSEMBLY, CONDENSER, RESISTOR		
- 33	38271	. SCREW, MACH, FIL H, 5-40 X 3/16 LG	2	ATT PT
- 34	206592	. . CAPACITOR, ALUM, ELBC, 4MFD 450VDC	2	
- 35	300734	. . RESISTOR, FXD CCMP, 510K, P/M 5% 1/2W	2	
- 36	317011	. . RESISTOR, FXD COMP, 470 OHMS, P/M 5% 1/2W	2	
- 37	317272	. . RESISTOR, FXD GEN, 47K, P/M 5% 2W	2	
- 38	213714	. . RESISTOR, FXD CCMP, 1.8K, P/M 5% 1/2W	2	
- 39	317025	. . RESISTOR, FXD COMP, 6.8K, P/M 5% 1/2W	2	
- 40	206595	. . CAPACITOR, MCLDED, 500PF P/M 5% 500VDC	2	
- 41	317037	. . RESISTOR, FXD GP, 220K, P/M 5% 1/2W	2	
- 42	213539	. . RESISTOR, FXD COMP, 150K, P/M 5% 1/2W	2	
- 43	186455	. . CLIP, FUSE	2	
- 44	118418	. . SCREW, MACH, RH, 5-40 X 5/32 LG	2	ATT PT
- 45	186454	. . BLOCK, MOUNTING, FUSE	1	
- 46	186453	. . BRACKET, PANEL	1	
- 47	194	. . SCREW, MACH, FLAT HD, 5-40 X 1/4 LG	1	ATT PT
- 48	187459	. . TERMINAL, LUG, NINS, 20AWG NO.8 MTG HOLE	2	
- 49	186452	. . STRIP, MOUNTING, RESISTOR AND CONDENSER	1	
- 50	206046	. CORD ASSEMBLY, RED	2	
- 50	206047	. CORD ASSEMBLY, BLACK	2	
- 51	450842	. . CLIP, ALIGATOR	4	
- 52	186447	. BRACKET, MOUNTING CASE	2	
- 53	38363	. SCREW, MACH-FIL H 8/32 X 5/32 LG	2	ATT PT
- 54	91514	. BUMPER	4	
- 55	186451	. BASE	1	



TOOLS AND TEST

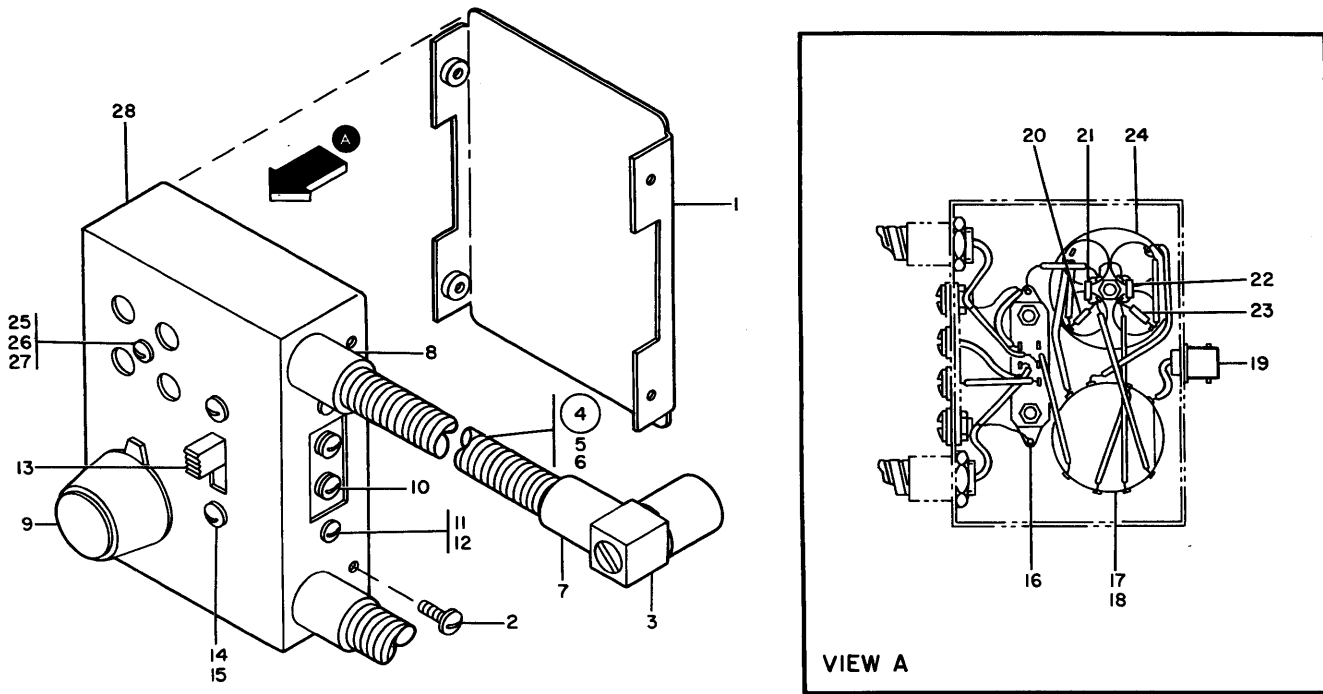

FIGURE 2. ADAPTER TOOL PROBE ASSEMBLY. SEE LIST 2.

LIST AND INDEX NUMBER	PART NUMBER	DESCRIPTION				UNITS PER ASM.	USABLE ON CODE
		1	2	3	4		
		ADAPTER TOOL PROBE ASSEMBLY					
2 -	45304E	PROBE ASSEMBLY, ADAPTER TOOL SEE FIGURE 2 FOR ILLUSTRATION				1	
- 1	846533	. COVER				1	
- 2	25197C	. SCREW, MACH, BS H, 4-40 X 0.250 LG		ATT PT	4		
- 3	846534	. CONNECTOR				2	
- 4	84654E	. TUBE ASSEMBLY, FLEXIBLE ARM				2	
- 5	824486	. NUT				2	ATT PT
- 6	846555	. WASHER				4	ATT PT
- 7	84654C	. FERRULE				1	
- 8	846554	. FERRULE				1	
- 9	846528	. KNOB				1	
- 10	846532	. POST				1	
- 11	251970	. SCREW, MACH, BS H, 4-40 X 0.250 LG		ATT PT	2		
- 12	37913	. NUT, HEX, 4-40				2	ATT PT
- 13	846531	. SWITCH, SLIDE				1	
- 14	251970	. SCREW, MACH, BS H, 4-40 X 0.250 LG		ATT PT	2		
- 15	37913	. NUT, HEX, 4-40				2	ATT PT
- 16	21492E	. LUG				2	
- 17	846525	. SWITCH, ROTARY				1	
- 18	824486	. NUT				2	ATT PT
- 19	317287	. JACK				1	
- 20	216741	. RESISTOR				1	
- 21	216499	. RESISTOR				1	
- 22	216746	. RESISTOR, FXD COMP, 1.0 MEG, 5% 1/4W				1	
- 23	216735	. RESISTOR, FXD, 510K, P/M 5% 1/4W				1	
- 24	846527	. TRIMMER, CERAMIC				1	
- 25	438550	. SCREW, MACH, BH, 4-40 X 1/2 LG		ATT PT	1		
- 26	37913	. NUT, HEX, 4-40				1	ATT PT
- 27	84652C	. SPACER				1	
- 28	84653C	. BOX, PROBE ADAPTER				1	

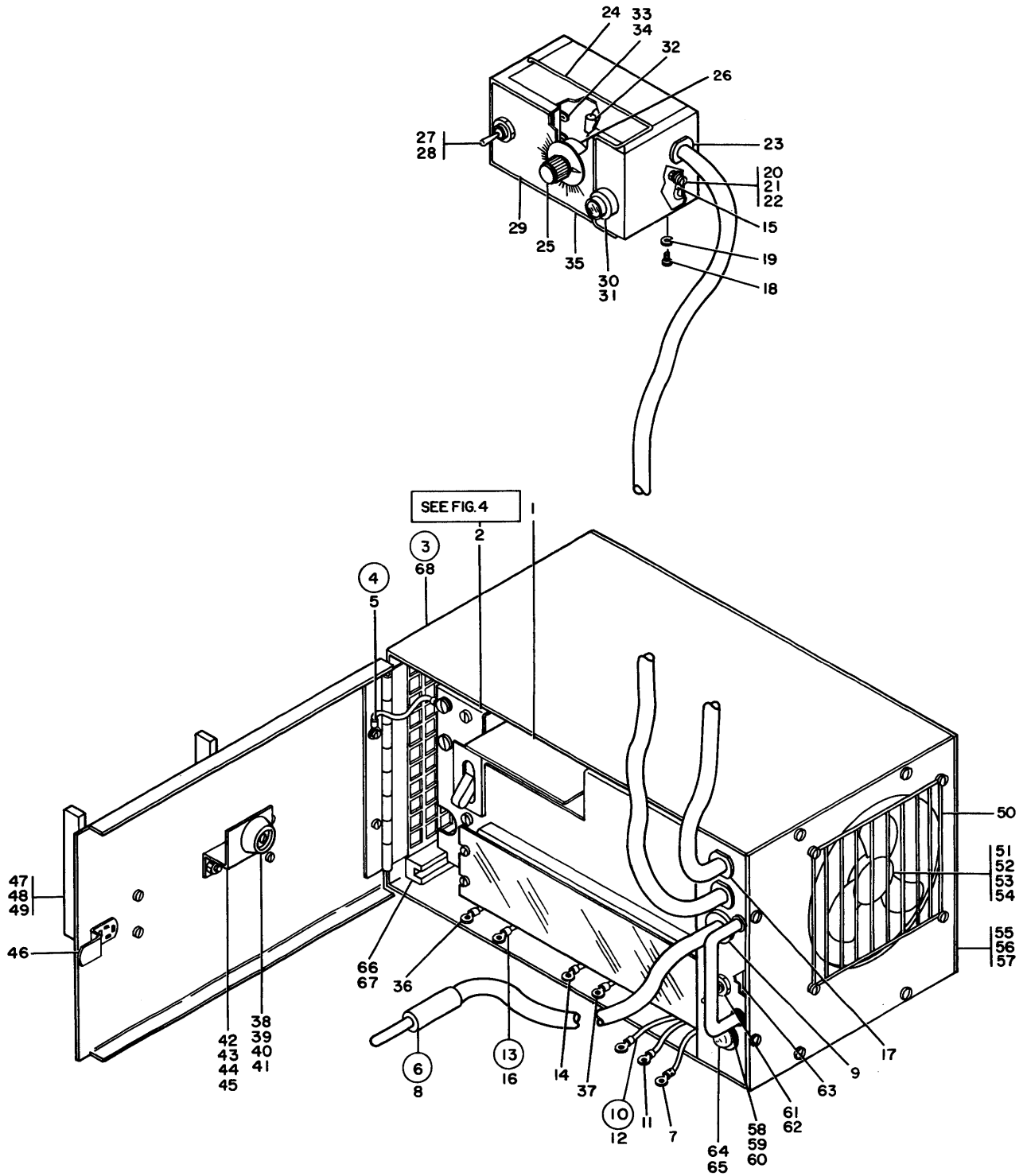
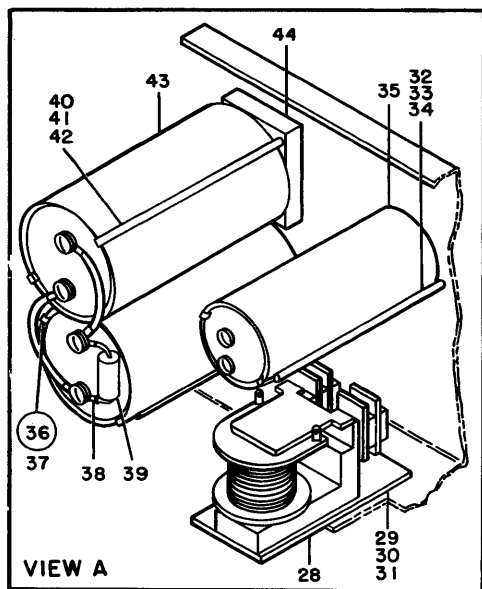

FIGURE 3. PORTABLE POWER SUPPLY ASSEMBLY. SEE LIST 3.

TOOLS AND TEST

LIST AND INDEX NUMBER	PART NUMBER	DESCRIPTION				UNITS PER ASM.	USABLE ON CODE
		1	2	3	4		
		PORTABLE POWER SUPPLY ASSEMBLY					
3 -	21086C	POWER SUPPLY ASM, PORTABLE SEE FIGURE 3 FOR ILLUSTRATION				1	
- 1	370616	. CARD ASSEMBLY				1	
- 2	47728C	. POWER SUPPLY ASSEMBLY SEE LIST 4 FOR DETAIL BREAKDOWN				1	
- 3	21085C	. HOUSING ASSEMBLY				1	
- 4	1127C55	. . JUMPER ASSEMBLY				2	
- 5	334932	. . . TERMINAL, RING, 18-22 AWG, #10 HOLE, INS				2	
- 6	216340	. . . CABLE ASSEMBLY, OUTPUT				1	
- 7	360370	. . . TERMINAL, RING, 14-16 AWG, NO.8 HOLE INS				3	
- 8	216339	. . . PLUG, PHONO				1	
- 9	92748	. . . GROMMET, STRAIN RELIEF-7/8"				1	
- 10	210871	. . . CCRD ASSEMBLY, AC INPUT				1	
- 11	92784	. . . TERMINAL, RING, 18-22 AWG, NO.8 HOLE, INS				1	
- 12	334921	. . . TERMINAL, RING, 18-22 AWG, #6 HOLE, INS				2	
- 13	216341	. . . CABLE ASSEMBLY, REMOTE CONTROL				1	
- 14	360370	. . . TERMINAL, RING, 14-16 AWG, NO.8 HOLE INS				2	
- 15	334921	. . . TERMINAL, RING, 18-22 AWG, #6 HOLE, INS				2	
- 16	92784	. . . TERMINAL, RING, 18-22 AWG, NO.8 HOLE, INS				6	
- 17	107611	. . . BUSHING				2	
- 18	183900	. . . SCREW, THD CTG, BH, 8-32 X 1/4 LG				1	
- 19	60646	. . . WASHER, LOCK, INT TEETH, NO. 8				1	
- 20	38235	. . . SCREW, MACH, BH, 6-32 X 0.312 LG				1	
- 21	62031	. . . WASHER, LOCK, INT TEETH, NO. 6 X 0.295 OD				1	
- 22	257187	. . . NUT, PLAIN, HEX 6-32				1	
- 23	107611	. . . BUSHING				1	
- 24	210875	. . . HANGER, CONTROL BOX				1	
- 25	519061	. . . KNCB, CONTROL, BLACK W/WHITE POINTER				1	
- 26	210846	. . . POTENTIOMETER, 1K, E/M 5% 2W				1	
- 27	128455	. . . SWITCH, TOGGLE				1	
- 28	216338	. . . WASHER, LOCK ATT PT				1	
- 29	210839	. . . ESCUTCHEON				1	
- 30	219628	. . . LAMP, INDICATOR				1	
- 31	334149	. . . HOLDER, LAMP				1	
- 32	521737	. . . CAPACITOR, ALUM, ELEC 50MFD 12V				2	
- 33	314047	. . . TERMINAL BOARD, 2 SOLDER LUGS				1	
- 34	1942	. . . SCREW, MACHINE, 6-32 X 1/4 LG ATT PT				1	
- 35	210855	. . . BOX, CONTROL				1	
- 36	92784	. . . TERMINAL, RING, 18-22 AWG, NO.8 HOLE, INS				2	
- 37	334921	. . . TERMINAL, RING, 18-22 AWG, #6 HOLE, INS				2	
- 38	301416	. . . BUMPER, RUBBER				1	
- 39	5528	. . . SCREW, MACH, BH, 8-32 X 0.625 LG ATT PT				1	
- 40	6318	. . . WASHER, LOCK, SPLIT, NO. 8 X 0.280 OD ATT PT				1	
- 41	257189	. . . NUT, HEX, 8-32 ATT PT				1	
- 42	210857	. . . BRACKET, BUMP MOUNTING				1	
- 43	38235	. . . SCREW, MACH, BH, 6-32 X 0.312 LG ATT PT				2	
- 44	6364	. . . WASHER, LOCK, SPLIT, NO. 6 X 1/4 OD ATT PT				2	
- 45	257187	. . . NUT, PLAIN, HEX 6-32 ATT PT				2	
- 46	210872	. . . FASTENER				1	
- 47	210868	. . . BRACKET, CABLE WRAP				2	
- 48	322550	. . . SCREW, MACH, BH, 6-32 X 1/2 LG ATT PT				4	
- 49	6364	. . . WASHER, LOCK, SPLIT, NO. 6 X 1/4 OD ATT PT				4	
- 50	177946	. . . GUARD, FAN				1	
- 51	597300	. . . FAN, AXIAL, 115V AC 1PH 60 HZ				1	
- 52	322065	. . . SCREW, MACH, BH, 6-32 X 5/8 LG ATT PT				4	
- 53	6364	. . . WASHER, LOCK, SPLIT, NO. 6 X 1/4 OD ATT PT				4	
- 54	257187	. . . NUT, PLAIN, HEX 6-32 ATT PT				4	
- 55	210866	. . . PLATE, END, FAN MOUNTING				1	
- 56	10170	. . . SCREW, MACH, BH, 6-32 X 1/4 LG ATT PT				6	
- 57	6364	. . . WASHER, LOCK, SPLIT, NO. 6 X 1/4 OD ATT PT				6	
- 58	159297	. . . HANDLE				2	
- 59	443	. . . SCREW, MACH, FIL H, 10-32 X 3/8 LG ATT PT				4	
- 60	9092	. . . WASHER, LOCK, SPLIT RING, 0.194 ID 0.3370 ATT PT				4	
- 61	128455	. . . SWITCH, TOGGLE				1	
- 62	216338	. . . WASHER, LOCK ATT PT				1	
- 63	216337	. . . INSULATOR				1	
- 64	317797	. . . LAMP, GLOW, 105 TO 125V 1/25W				1	
- 65	442814	. . . HOLDER, LAMP				1	
- 66	210870	. . . BAR, SLIDE				2	
- 67	438558	. . . SCREW, PLATE MTG ATT PT				6	
- 68	210867	. . . HOUSING				1	



FOR PARTS  
NOT SHOWN  
SEE FIG. 3

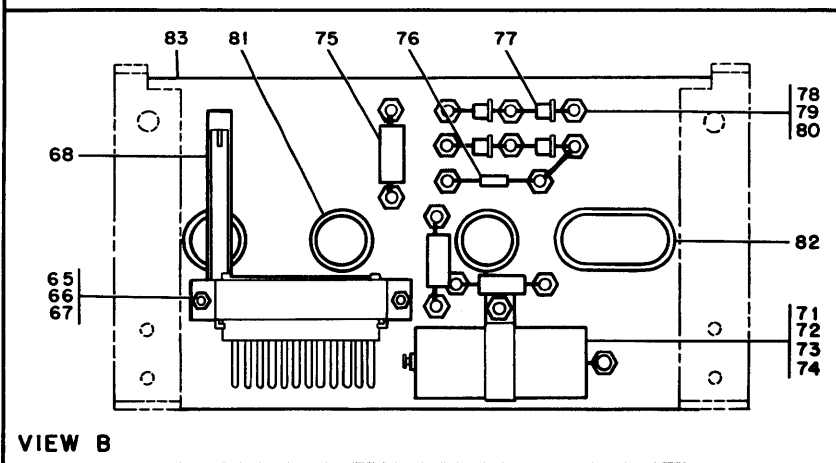
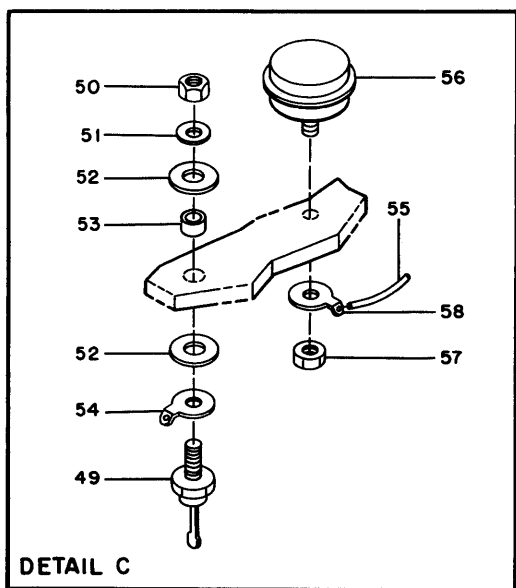
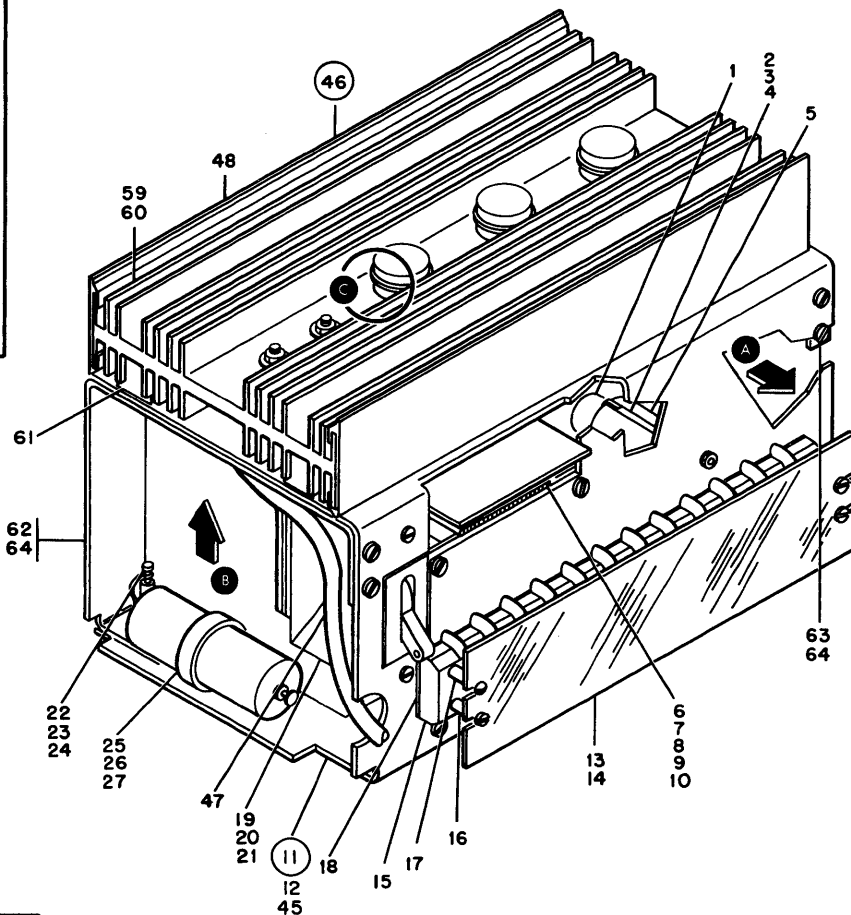

FIGURE 4. POWER SUPPLY ASSEMBLY. SEE LIST 4.

TOOLS AND TEST

LIST AND INDEX NUMBER	PART NUMBER	DESCRIPTION	UNITS PER ASM.	USABLE ON CODE
		POWER SUPPLY ASSEMBLY		
4 -	477280	POWER SUPPLY ASSEMBLY SEE LIST 3-2 FOR NEXT HIGHER ASSEMBLY AND FIG. 4 FOR ILLUSTRATION	REF	
- 1	526378	. INSULATION	2	
- 2	473576	. CAPACITOR	2	
- 3	38051	. NUT, PLAIN, HEX, 6-32 X 1/4 FL W ATT PT	2	
- 4	62031	. WASHER, LCKK, INT TEETH, NO.6 X 0.295 OD ATT PT	2	
- 5	210873	. CAPACITOR, 60 CPS	1	
- 6	210844	. REGULATOR, FERRORESONANT, 60 HZ	1	
- 7	32617	. SCREW, MACH, BH, 10-32 X 0.438 LG ATT PT	4	
- 8	56121	. WASHER, LOCK, INT TEETH, NO.10 X 0.3810D ATT PT	4	
- 9	47242	. WASHER, FLAT, NO.12 X 1/2 OD X 0.062 THK ATT PT	4	
- 10	11558	. NUT, PLAIN, HEX, 10-32 X 3/8 FL W ATT PT	4	
- 11	477284	. PLATE ASSEMBLY	1	
- 12	28413	. SCREW, MACH, BH, 10-32 X 5/16 LG ATT PT	8	
- 13	187855	. SHIELD, BLOCK, 2 IN. X 0.062 X 7 3/4 LG	1	
- 14	210584	. SCREW, MACH, RD HD, 6-32 X 0.250LG ATT PT	1	
- 15	18198	. BLOCK, 12 DBL SCREW TERMINALS	1	
- 16	209484	. STUD, SHD MIG, 8-32 X 9/16 LG ATT PT	3	
- 17	209483	. STUD, MCUNTING, 6-32 X 9/16 LG ATT PT	1	
- 18	557587	. INSULATOR	1	
- 19	207348	. CIRCUIT BREAKER, 1 PCLE 60V DC 6 AMP	1	
- 20	38235	. SCREW, MACH, EH, 6-32 X 0.312 LG ATT PT	2	
- 21	62031	. WASHER, LCKK, INT TEETH, NO.6 X 0.295 OD ATT PT	2	
- 22	533534	. TERMINAL	1	
- 23	10170	. SCREW, MACH, BH, 6-32 X 1/4 LG ATT PT	1	
- 24	62031	. WASHER, LOCK, INT TEETH, NO.6 X 0.295 OD ATT PT	1	
- 25	208229	. CAPACITOR, FXD ELECT, 70MFD P100M10%15V	1	
- 26	55726	. SCREW, MACH, BH, 6-32 X 0.188 LG ATT PT	1	
- 27	62031	. WASHER, LCKK, INT TEETH, NO.6 X 0.295 OD ATT PT	1	
- 28	210874	. RELAY, DPDT	1	
- 29	477252	. BRACKET	1	
- 30	58207	. SCREW, MACH, UNDRCT BH, 8-32 X 1/4 LG ATT PT	4	
- 31	60646	. WASHER, LCKK, INT TEETH, NO. 8 ATT PT	4	
- 32	473426	. CLAMP	2	
- 33	38051	. NUT, PLAIN, HEX, 6-32 X 1/4 FL W ATT PT	2	
- 34	62031	. WASHER, LCKK, INT TEETH, NO.6 X 0.295 OD ATT PT	2	
- 35	210845	. CAPACITOR, FXD ELECT, 1.25KMPD P100M10%25V	1	
- 36	208989	. JUMPER ASM, RIK 3 IN. 12AWG 1 LUG EA END	2	
- 37	2101326	. TERMINAL, RING, 12-10 AWG	2	
- 38	54856	. LUG, TERMINAL	2	
- 39	301881	. RESISTOR, FXD COMP, 240 OHMS, P/M 5% 2W	1	
- 40	473543	. CLAMP ASM, CAPACITOR	4	
- 41	38051	. NUT, PLAIN, HEX, 6-32 X 1/4 FL W ATT PT	4	
- 42	62031	. WASHER, LOCK, INT TEETH, NO.6 X 0.295 OD ATT PT	4	
- 43	479953	. CAPACITOR, ELECTROLYTIC, 15KMPD	2	
- 44	473406	. SPACER	1	
- 45	477287	. PLATE	1	

TOOLS AND TEST

LIST AND INDEX NUMBER	PART NUMBER	DESCRIPTION	UNITS PER ASM.	USABLE ON CODE
4 - 46	477285	. HEAT SINK ASSEMBLY	1	
- 47	477283	. . CABLE ASSEMBLY	1	
- 48	473536	. . SEAL	2	
- 49	216197	. . RECTIFIER, SILICCN-ALLOY	2	
- 50	11891	. . NUT, PLAIN, HEX, 10-32 X 3/8 FL W BRS ATT PT	2	
- 51	45690	. . WASHER, FL, NO. 10 X 7/16 CD X 1/32 THK ATT PT	2	
- 52	217019	. . WASHER, INSULATING	4	
- 53	473582	. . INSULATOR	2	
- 54	316996	. . TERMINAL, LUG, NINS, 9AWG NO. 8 MTG HOLE	2	
- 55	219423	. . TUBE, RUBBER, 0.085 ID X 0.120 OD X 2 LG	6	
- 56	369214	. . TRANSISTOR, TYPE 108	3	
- 57	11891	. . NUT, PLAIN, HEX, 10-32 X 3/8 FL W BRS ATT PT	3	
- 58	316996	. . TERMINAL, LUG, NINS, 9AWG NO. 8 MTG HOLE	3	
- 59	477288	. . HEAT SINK	1	
- 60	79779	. . SCREW, THD CTG, BH, NO. 6 X 3/4 LG ATT PT	4	
- 61	473531	. . INSULATOR	4	
- 62	730176	. . BRACKET, LOWER UNIT SUPPORT	1	
- 63	730175	. . BRACKET, UPPER UNIT SUPPORT	1	
- 64	473544	. . SCREW, SELF-TAP, BH, NO. 6, 1/2LG ATT PT	4	
- 65	477203	. . BRACKET	1	
- 66	8235	. . SCREW, MACHINE ATT PT	2	
- 67	62031	. . WASHER, LOCK, INT TEETH, NO.6 X 0.295 OD ATT PT	2	
- 68	216206	. . GUIDE, SINGLE CARD LONG	1	
- 71	208229	. . CAPACITOR, FXD ELECT, 700MFD P100M10X15V	1	
- 72	38235	. . SCREW, MACH, BH, 6-32 X 0.312 LG ATT PT	1	
- 73	62031	. . WASHER, LOCK, INT TEETH, NO.6 X 0.295 OD ATT PT	1	
- 74	38051	. . NUT, PLAIN, HEX, 6-32 X 1/4 FL W ATT PT	1	
- 75	207324	. . RESISTOR, FXD, WW, 0.1 CHP, P/M 5% 5W	3	
- 76	317012	. . RESISTOR, FXD COMP, 510 OHMS, P/M 5% 1/2W	1	
- 77	207316	. . SEMICONDUCTOR DEVICE, DIODE-120V 3A	4	
- 78	533534	. . TERMINAL	15	
- 79	55726	. . SCREW, MACH, BH, 6-32 X 0.188 LG ATT PT	15	
- 80	62031	. . WASHER, LOCK, INT TEETH, NO.6 X 0.295 OD ATT PT	15	
- 81	473533	. . GROMMET	AR	
- 82	473442	. . GROMMET	AR	
- 83	477289	. . COVER	1	

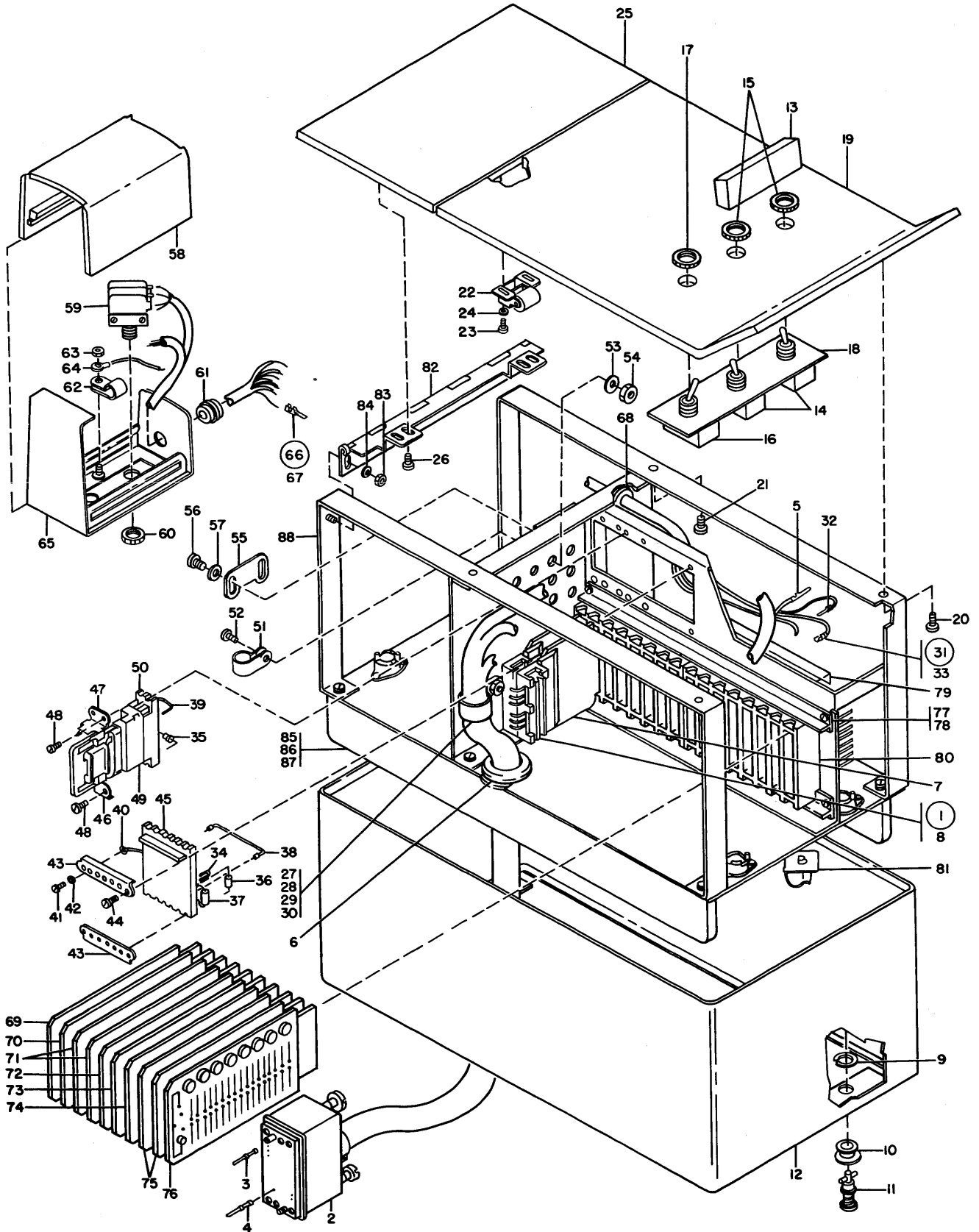

FIGURE 5. REMOTE RECYCLE CONTROL ASSEMBLY. SEE LIST 5.

TOOLS AND TEST

LIST AND INDEX NUMBER	PART NUMBER	DESCRIPTION	UNITS PER ASM.	USABLE ON CODE
		REMOTE RECYCLE CONTROL ASSEMBLY		
5 -	724830	CONTROL ASSEMBLY, REMOTE RECYCLE SEE FIGURE 5 FOR ILLUSTRATION	1	
- 1	724843	. CABLE ASSEMBLY, EXTERNAL	1	
- 2	722867	. . CONNECTOR, RECEPTACLE, 75 POSITION	1	
- 3	723155	. . CONTACT, ELEC, 20-22	49	
- 4	532903	. . CONTACT, ELEC, 18-20	7	
- 5	187243	. . TERMINAL, SMALL TAPER	11	
- 6	317367	. . GROMMET, RUBBER, FOR 7/8 HOLE X 1/16 PNL	1	
- 7	216300	. . PLUG, STRAIN RELIEF	2	
- 8	216304	. . STRAIN RELIEF	2	
- 9	312575	. RING, RETAINING, 0.4375 ID X 0.040 THK	4	
- 10	510352	. GROMMET	4	
- 11	8C2130	. STUD, CAMLOC	4	
- 12	724800	. COVER, SIDE	1	
- 13	724809	. BAR, DOUBLE THRU SWITCH	1	
- 14	363420	. SWITCH, TOGGLE, DEDT	2	
- 15	179744	. NUT, PLAIN, RD, 15/32-32 X 39/64 DIA ATT PT	2	
- 16	479319	. SWITCH, TOGGLE, DEDT, 20V 0.1A	1	
- 17	179744	. NUT, PLAIN, RD, 15/32-32 X 39/64 DIA ATT PT	1	
- 18	724808	. RETAINER, SWITCH	1	
- 19	724802	. COVER, TOP	1	
- 20	221790	. SCREW, MACH, BH, 8-32 X 3/16 LG ATT PT	2	
- 21	58207	. SCREW, MACH, UNDRCT BH, 8-32 X 1/4 LG ATT PT	2	
- 22	513668	. CATCH, FRICTION LATCH	1	
- 23	221790	. SCREW, MACH, BH, 8-32 X 3/16 LG ATT PT	2	
- 24	22478	. WASHER, FLAT, 0.175ID X 0.375OD 0.03 THK ATT PT	2	
- 25	724807	. DOOR	1	
- 26	221790	. SCREW, MACH, BH, 8-32 X 3/16 LG ATT PT	4	
- 27	2114108	. CLAMP, CABLE, 0.562 DIAMETER	1	
- 28	32042	. SCREW, MACH, BH, 10-32 X 3/8 LG ATT PT	1	
- 29	45690	. WASHER, FL, NO.10 X 7/16 OD X 1/32 THK ATT PT	1	
- 30	11598	. NUT, PLAIN, HEX, 10-32 X 3/8 FL W ATT PT	1	
- 31	724840	. CABLE ASSEMBLY, INTERNAL	1	
- 32	187243	. . TERMINAL, SMALL TAPER	22	
- 33	216265	. . TERMINAL, QUICK DISCON, NCN-INS, 20AWG	30	
- 34	2C5331	. JUMPER, 0.125 BRASS	2	
- 35	441318	. DIODE ASSEMBLY, SELENIUM	2	
- 36	234457	. RESISTOR ASSEMBLY, 2200 OHM, 2W	2	
- 37	2103073	. RESISTOR ASSEMBLY, 680 OHM, 1/2W	3	
- 38	129244	. JUMPER ASSEMBLY	5	
- 39	129243	. JUMPER ASM, BLU 3-1/2 20AWG 1 LUG EA END	6	
- 40	2C9314	. JUMPER ASSEMBLY	1	
- 41	10170	. SCREW, MACH, BH, 6-32 X 1/4 LG ATT PT	1	
- 42	56722	. WASHER, LOCK, EXTERNAL TOOTH NO. 6 ATT PT	1	
- 43	2E4424	. CLIP, RELAY MOLDING BOTTOM MOUNTING	2	
- 44	198363	. SCREW, SELF-TAP, BH, NO. 4 X 1/2 LG ATT PT	4	
- 45	324999	. TERMINAL BOARD, 109 FEEDTHRU TERMINALS	1	
- 46	3C8704	. CLIP, MOLDING	2	
- 47	159944	. CLIP, SPRING TENSION-TERMINAL MOLDING	2	
- 48	198363	. SCREW, SELF-TAP, BH, NO. 4 X 1/2 LG ATT PT	8	
- 49	719003	. RELAY ASSEMBLY, 4 POSITION	2	
- 50	344599	. MOLDING ASSEMBLY, TERMINAL	2	
- 51	2102365	. CLAMP, LOCK, 0.330 ID	1	
- 52	38235	. SCREW, MACH, BH, 6-32 X 0.312 LG ATT PT	1	
- 53	45642	. WASHER, FL, NP.6 X 11/32 CD X 0.040 THK ATT PT	1	
- 54	257187	. NUT, PLAIN, HEX 6-32 ATT PT	1	
- 55	5C7068	. STRIKE, COVER CATCH	1	
- 56	10170	. SCREW, MACH, BH, 6-32 X 1/4 LG ATT PT	2	
- 57	257986	. WASHER, FLAT, NO. 6 X 0.312 OD ATT PT	2	





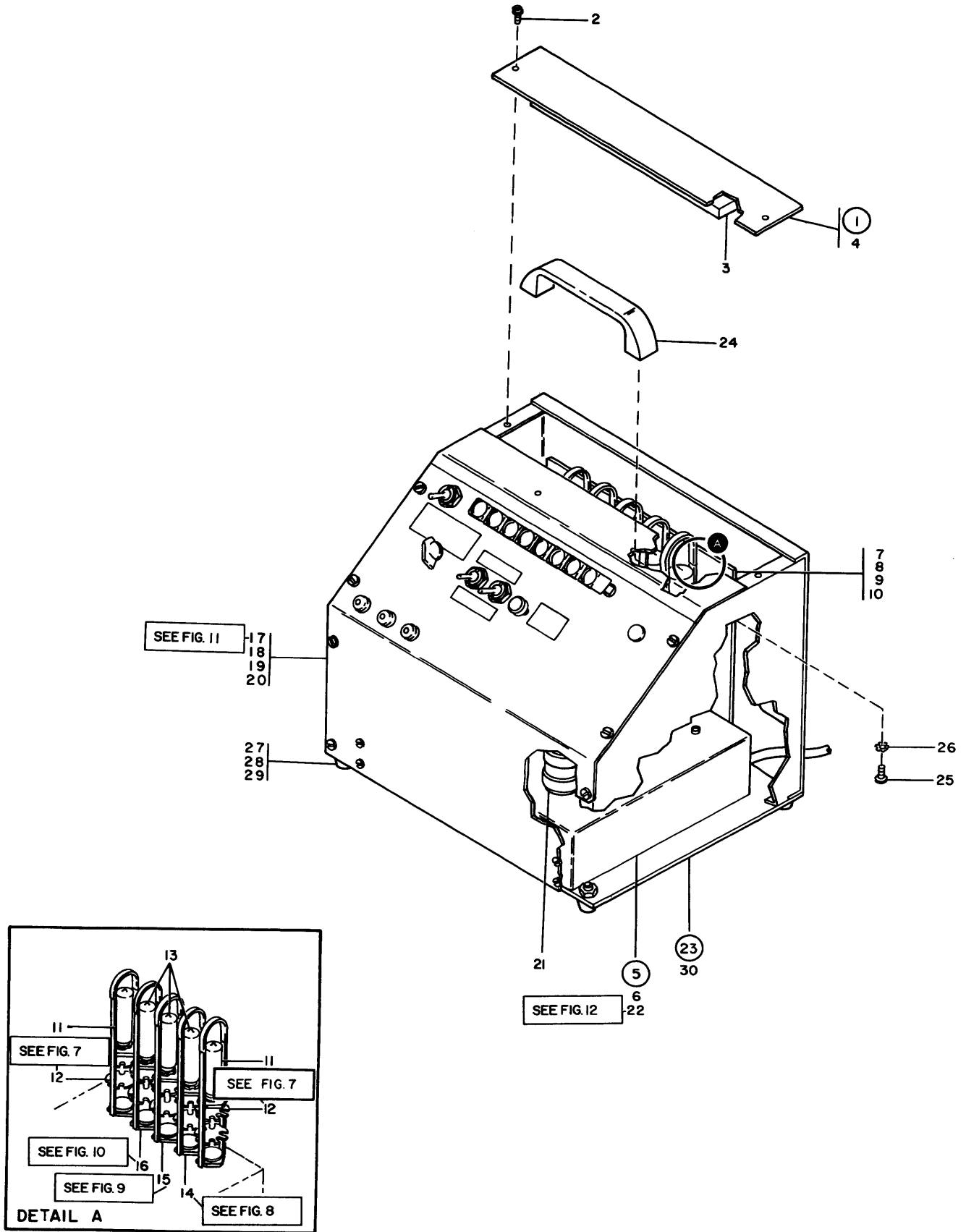
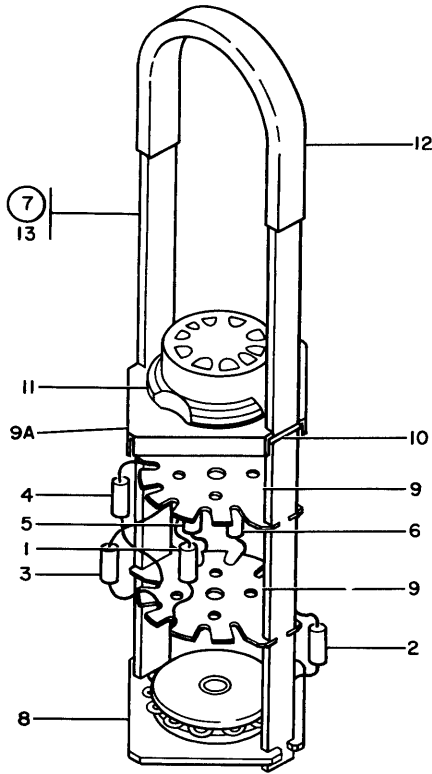
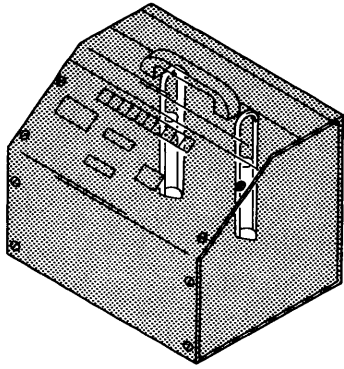

FIGURE 6. DATA TRANSCIVER SIGNAL SIMULATOR. SEE LIST 6.





FOR PARTS  
NOT SHOWN  
SEE FIG. 6

FIGURE 7. CF-22 PLUGGABLE UNIT ASSEMBLY. SEE LIST 7.

LIST AND INDEX NUMBER	PART NUMBER	DESCRIPTION				UNITS PER ASM.	USABLE ON CODE
		1	2	3	4		
		CF-22 PLUGGABLE UNIT ASSEMBLY					
7 -	338106	PLUGGABLE UNIT ASSEMBLY, CF-22 SEE LIST 6-12 FOR NEXT HIGHER ASSEMBLY AND FIG. 7 FOR ILLUSTRATION				REF	
- 1	301826	. RESISTOR, COMP, 22K, P/M 10% 2W				1	
- 2	322731	. RESISTOR, CCMP, 18K, F/M 5% 2W				1	
- 3	300736	. RESISTOR, FXD CCMP, 1 MEG, F/M 5% 1/2W				1	
- 4	213556	. RESISTOR, FXD CCMP, 680K, F/M 5% 1/2W				1	
- 5	300728	. RESISTOR, FXD CCMP, 100K, F/M 5% 1/2W				1	
- 6	300725	. RESISTOR, COMP, 47K, F/M 20% 1/2W				1	
- 7	338110	. FRAME ASSEMBLY				1	
- 8	3C9900	. . BASE, PLUGGABLE UNIT				1	
- 9	3C9922	. . WAFER				2	
- 9A	2102096	. . PLATE				1	
- 10	309921	. . CLIP				2	
- 11	338108	. . SOCKET, ELECTRON TUBE				1	
- 12	3C9920	. . INSULATOR, BAIL				1	
- 13	309919	. . BAIL				1	

TOOLS AND TEST

FOR PARTS  
NOT SHOWN  
SEE FIG. 6

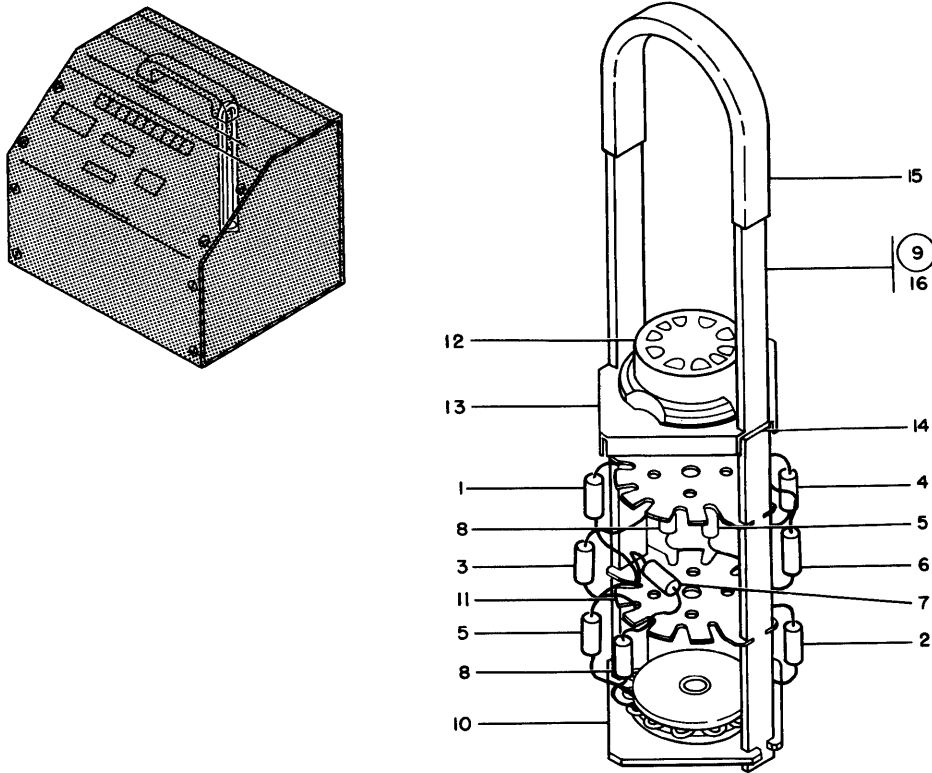

FIGURE 8. TR-5 TRIGGER PLUGGABLE UNIT ASSEMBLY. SEE LIST 8.

LIST AND INDEX NUMBER	PART NUMBER	DESCRIPTION				UNITS PER ASM.	USABLE ON CODE
		1	2	3	4		
		TR-5 TRIGGER PLUGGABLE UNIT ASSEMBLY					
8 -	261159	PLUGGABLE UNIT ASSEMBLY, TR-5 TRIGGER SEE LIST 6-14 FOR NEXT HIGHER ASSEMBLY AND FIG. 8 FOR ILLUSTRATION				REF	
- 1	213693	. RESISTOR, FXD COMP, 1K, E/M 5% 1/2W				1	
- 2	3C0720	. RESISTOR, FXD COMP, 7.5K E/M 5% 1/2W				1	
- 3	3C0721	. RESISTOR, FXD CCMP, 10K, E/M 5% 1/2W				1	
- 4	300722	. RESISTOR, FXD CCMP, 12K, 5%, 1/2W				1	
- 5	3C0729	. RESISTOR, FXD COMP, 200K, 5%, 1/2W				2	
- 6	3C1824	. RESISTOR, CCMP, 20K, P/M 5% 1W				1	
- 7	3C0712	. CAPACITOR, CERAMIC, 40PF, 5%, 500VDC				1	
- 8	3C0714	. CAPACITOR, CERAMIC, 100PF, 5%, 500VDC				2	
- 9	309944	. FRAME ASSEMBLY				1	
- 10	3C990C	. . . BASE, PLUGGABLE UNIT				1	
- 11	309923	. . . WAFER				2	
- 12	2111258	. . . SOCKET, ELECTRON TUBE				1	
- 13	2102096	. . . PLATE				1	
- 14	21C2571	. . . CLIP				1	
- 15	3C992C	. . . INSULATOR, BAIL				1	
- 16	3C9925	. . . BAIL				1	

FOR PARTS  
NOT SHOWN  
SEE FIG. 6

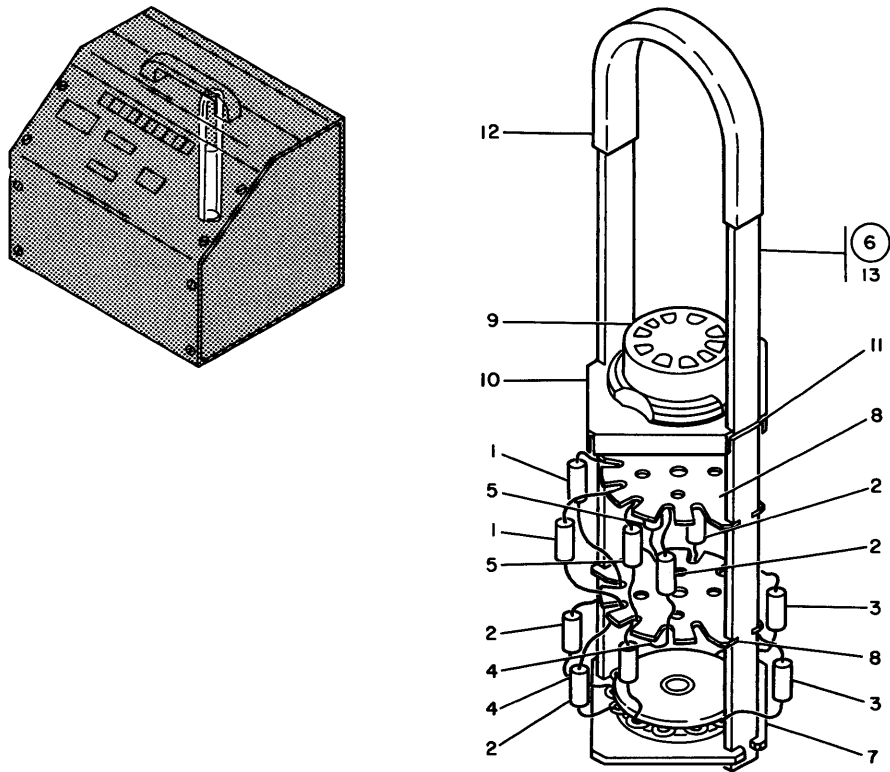

FIGURE 9. TR-1 TRIGGER PLUGGABLE UNIT ASSEMBLY. SEE LIST 9.

LIST AND INDEX NUMBER	PART NUMBER	DESCRIPTION				UNITS PER ASM.	USABLE ON CODE
		1	2	3	4		
		TR-1 TRIGGER PLUGGABLE UNIT ASSEMBLY					
9 -	3C0638	PLUGGABLE UNIT ASSEMBLY, TR-1 TRIGGER SEE LIST 6-15 FOR NEXT HIGHER ASSEMBLY AND FIG. 9 FOR ILLUSTRATION				REF	
- 1	213693	. RESISTOR, FXD COMP, 1K, E/M 5% 1/2W				2	
- 2	300729	. RESISTOR, FXD CCMP, 200K, 5%, 1/2W				4	
- 3	301824	. RESISTOR, CCME, 20K, E/M 5% 1W				2	
- 4	3C0712	. CAPACITOR, CERAMIC, 40PF, 5%, 500VDC				2	
- 5	300714	. CAPACITOR, CERAMIC, 100PF, 5%, 500VDC				2	
- 6	3C9944	. FRAME ASSEMBLY				1	
- 7	3C9900	. . . BASE, PLUGGABLE UNIT				1	
- 8	309923	. . . WAFER				2	
- 9	2111258	. . . SOCKET, ELECTRON TUBE				1	
- 10	2102096	. . . PLATE				1	
- 11	2102571	. . . CLIP				1	
- 12	3C9920	. . . INSULATOR, BAIL				1	
- 13	309929	. . . BAIL				1	

FOR PARTS  
NOT SHOWN  
SEE FIG. 6

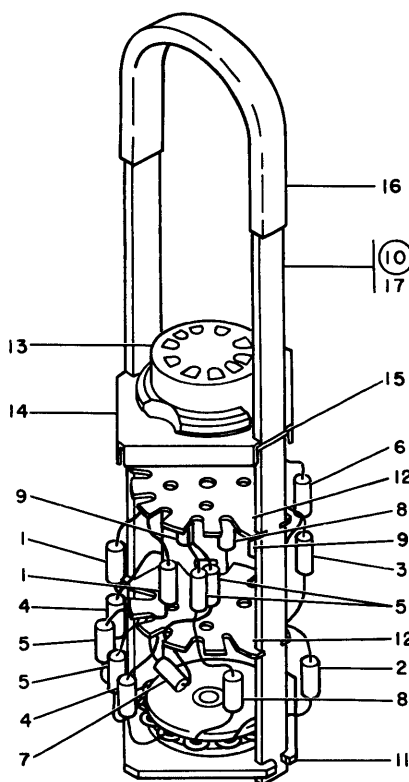
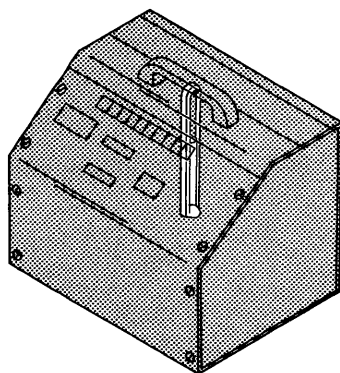

FIGURE 10. TR-3 TRIGGER PLUGGABLE UNIT ASSEMBLY. SEE LIST 10.

LIST AND INDEX NUMBER	PART NUMBER	DESCRIPTION				UNITS PER ASM.	USABLE ON CODE
		1	2	3	4		
		TR-3 TRIGGER PLUGGABLE UNIT ASSEMBLY					
10 -	3C0642	PLUGGABLE UNIT ASSEMBLY, TR-3 TRIGGER SEE LIST 6-16 FOR NEXT HIGHER ASSEMBLY AND FIG. 10 FOR ILLUSTRATION				REF	
- 1	213693	. RESISTOR, FXD COMP, 1K, E/M 5% 1/2W				2	
- 2	3C0720	. RESISTOR, FXD COMP, 7.5K E/M 5% 1/2W				1	
- 3	3C0722	. RESISTOR, FXD CCMP, 12K, 5%, 1/2W				1	
- 4	300727	. RESISTOR, FXD CCMP, 82K, E/M 5% 1/2W				2	
- 5	3C0729	. RESISTOR, FXD COMP, 200K, 5%, 1/2W				4	
- 6	3C1824	. RESISTOR, CCMP, 20K, E/M 5% 1W				1	
- 7	3C0710	. CAPACITOR, CERAMIC, 10PF, 10%, 500VDC				1	
- 8	300712	. CAPACITOR, CERAMIC, 40PF, 5%, 500VDC				2	
- 9	3C0714	. CAPACITOR, CERAMIC, 100PF, 5%, 500VDC				2	
- 10	3C9944	. FRAME ASSEMBLY				1	
- 11	3C9900	. . BASE, PLUGGABLE UNIT				1	
- 12	309923	. . WAFER				2	
- 13	2111258	. . SOCKET, ELECTRON TUBE				1	
- 14	21C2C96	. . PLATE				1	
- 15	2102571	. . CLIP				1	
- 16	3C9920	. . INSULATOR, PAIL				1	
- 17	3C9929	. . BAIL				1	

FOR PARTS  
NOT SHOWN  
SEE FIG. 6

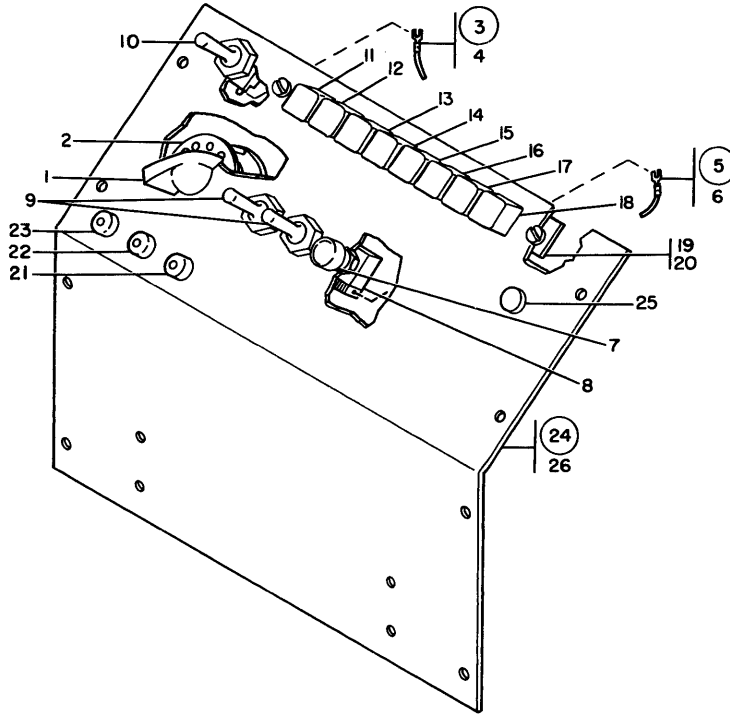
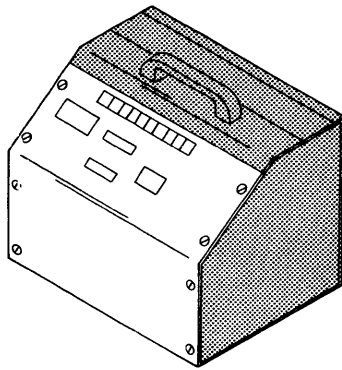

FIGURE 11. FRONT COVER ASSEMBLY. SEE LIST 11.

LIST AND INDEX NUMBER	PART NUMBER	DESCRIPTION				UNITS PER ASM.	USABLE ON CODE
		1	2	3	4		
		FRONT COVER ASSEMBLY					
11 -	3389C4	COVER ASSEMBLY, FRCNT SEE LIST 6-17 FOR NEXT HIGHER ASSEMBLY AND FIG. 11 FOR ILLUSTRATION				REF	
- 1	317173	. KNOB, BAR TYPE WITH POINTER				1	
- 2	338916	. SWITCH, SELECTOR				1	
- 3	249271	. JUMPER ASSMBLY				1	
- 4	115186	. . TERMINAL, LUG				1	
- 5	334067	. JUMPER ASSEMBLY				1	
- 6	126967	. . TERMINAL, SPADE, 20-24 AWC, #6 HOLE, NINS				1	
- 7	169138	. KNOB, SWITCH BLACK				1	
- 8	215680	. SWITCH, PUSH, NC, 125VAC 1 AMP				1	
- 9	118463	. SWITCH, TOGGLE, SPST				2	
- 10	331698	. SWITCH, TOGGLE, SPDT				1	
- 11	1105024	. BUTTON, KEY X				1	
- 12	1105015	. BUTTON, KEY O				1	
- 13	1105014	. BUTTON, KEY N				1	
- 14	1105018	. BUTTON, KEY R				1	
- 15	1105294	. BUTTON, KEY 7				1	
- 16	1105291	. BUTTON, KEY 4				1	
- 17	1105289	. BUTTON, KEY 2				1	
- 18	1105288	. BUTTON, KEY 1				1	
- 19	338915	. SWITCH, CODE				1	
- 20	34512	. SCREW, BH, 8-32 X 0.375 IG				2	ATT PT
- 21	322599	. JACK, TIP				1	
- 22	322609	. JACK, TIP, RED				1	
- 23	338159	. JACK, TEST				1	
- 24	3389C4	. COVER ASSEMBLY				1	
- 25	234056	. . PLUG, SNAP-IN				1	
- 26	338926	. . COVER				1	



FOR PARTS  
NOT SHOWN  
SEE FIG. 6

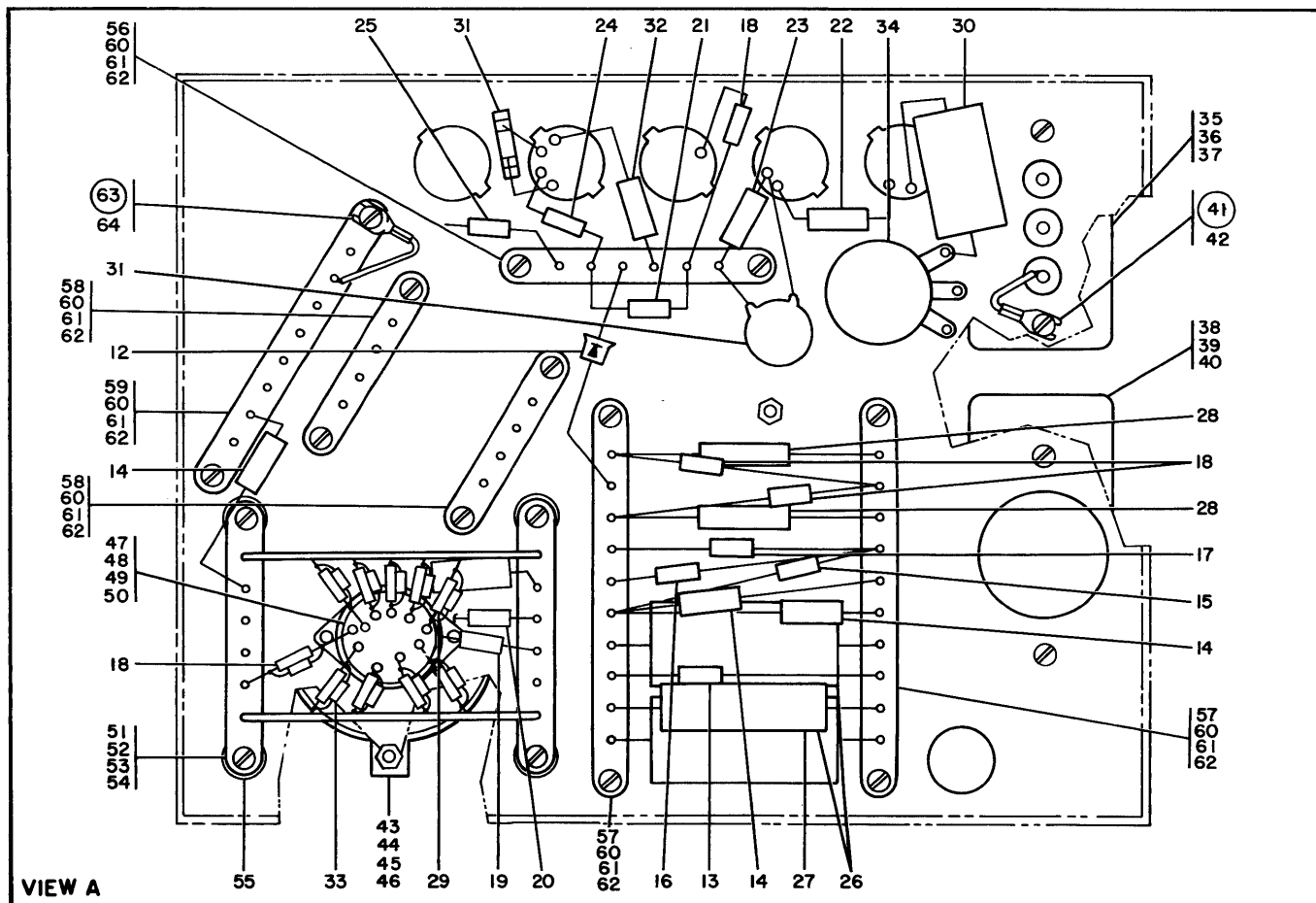
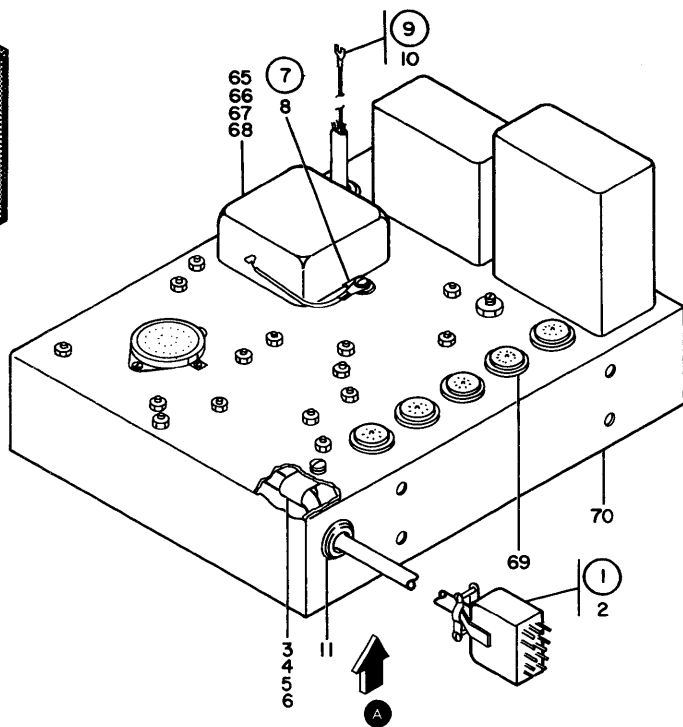
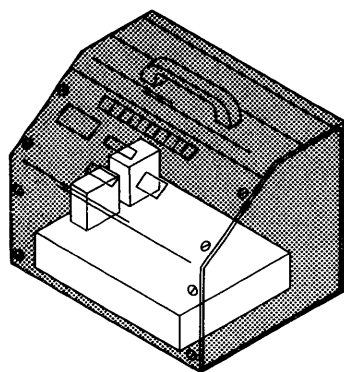

FIGURE 12. CHASSIS ASSEMBLY. SEE LIST 12.

TOOLS AND TEST

LIST AND INDEX NUMBER	PART NUMBER	DESCRIPTION	UNITS	USABLE ON CODE
			PER ASM.	
		CHASSIS ASSEMBLY		
12 -	338903	CHASSIS ASSEMBLY SEE LIST 6-22 FOR NEXT HIGHER ASSEMBLY AND FIG. 12 FOR ILLUSTRATION	REF	
- 1	338920	. CABLE ASSEMBLY	1	
- 2	321057	. CONNECTOR, PLUG, ELEC, 8 FEMALE CONTACTS	1	
- 3	167338	. CLIP, CABLE, 3/8 DIA LOOP 9/32 MTG HOLE	1	
- 4	32042	. SCREW, MACH, BH, 10-32 X 3/8 LG ATT PT	1	
- 5	56079	. WASHER, LCKK, EXT TEETH, 0.195ID 0.410OD ATT PT	1	
- 6	11598	. NUT, PLAIN, HEX, 10-32 X 3/8 FL W ATT PT	1	
- 7	309758	. JUMPER ASSEMBLY	1	
- 8	115186	. . TERMINAL, LUG	1	
- 9	338917	. CABLE ASSEMBLY	1	
- 10	115186	. . TERMINAL, LUG	3	
- 11	204362	. GROMMET, RUBBER, FOR 5/8 HOLE X 1/16 ENL	2	
- 12	333264	. SEMICONDUCTOR DEVICE, DIODE	1	
- 13	317030	. RESISTOR, FXD COMP, 47K, E/M 5% 1/2W	1	
- 14	301825	. RESISTOR, CCMP, 22K, P/M 5% 1W	3	
- 15	323900	. RESISTOR, FXD CCMP, 22K, P/M 5% 1/2W	1	
- 16	317025	. RESISTOR, FXD COMP, 6.8K, P/M 5% 1/2W	1	
- 17	317029	. RESISTOR, FXD, 33K, PM 5% 1/2W	1	
- 18	300728	. RESISTOR, FXD CCMP, 100K, P/M 5% 1/2W	13	
- 19	322347	. RESISTOR, FXD CCMP, 560 OHMS, P/M 5% 1/2W	1	
- 20	317031	. RESISTOR, FXD CCMP, 68K, E/M 5% 1/2W	1	
- 21	321195	. RESISTOR, FXD CCMP, 1.2 MEG, P/M 5% 1/2W	1	
- 22	317060	. RESISTOR, FXD CCMP, 6.8K, P/M 5% 1W	1	
- 23	317065	. RESISTOR, CCMP, 27K, E/M 5% 1W	1	
- 24	300736	. RESISTOR, FXD CCMP, 1 MEG, E/M 5% 1/2W	1	
- 25	317028	. RESISTOR, FXD CCMP, 18K, E/M 5% 1/2W	1	
- 26	321019	. CAPACITOR, TUBULAR, 20MFD, 25CVDC	2	
- 27	322821	. CAPACITOR, TUBULAR, 0.25MFD, 400VDC	1	
- 28	317338	. CAPACITOR, TUBULAR, 1000PF, 500VDC	2	
- 29	521736	. CAPACITOR, 1MFD	1	
- 30	266533	. CAPACITOR, ELECT, 4MFD, 250VDC	1	
- 31	317262	. CAPACITOR, FXD CER, 0.01MFD P80M20% 450V	2	
- 32	360032	. CAPACITOR, TUBULAR, 200PF, 500VDC	1	
- 33	317339	. CAPACITOR, CERAMIC, 33PF, 500VDC	10	
- 34	322235	. POTENTIOMETER	1	
- 35	338174	. INDUCTOR	1	
- 36	38235	. SCREW, MACH, BH, 6-32 X 0.312 LG ATT PT	2	
- 37	56722	. WASHER, LCKK, EXTERNAL TOOTH NO. 6 ATT PT	2	
- 38	338175	. OSCILLATOR UNIT, 180 HZ	1	
- 39	38235	. SCREW, MACH, BH, 6-32 X 0.312 LG ATT PT	2	
- 40	56722	. WASHER, LOCK, EXTERNAL TOOTH NO. 6 ATT PT	2	
- 41	309758	. JUMPER ASSEMBLY	1	
- 42	115186	. . TERMINAL, LUG	1	
- 43	338914	. . CLAMP, TUBE	1	
- 44	34512	. SCREW, BH, 8-32 X 0.375 LG ATT PT	2	
- 45	55901	. WASHER, LCKK, EXT TEETH, NO.8 X 0.381OD ATT PT	2	
- 46	257189	. NUT, HEX, 8-32 ATT PT	2	
- 47	338913	. SOCKET, MBS	1	
- 48	338238	. SCREW, MACH, BH, 4-40 NC X 0.3125 LG ATT PT	2	
- 49	257584	. WASHER, LCKK, SPLIT, 1/8 ID X 13/64 OD ATT PT	2	
- 50	38214	. NUT ATT PT	2	
- 51	317157	. STRIP, TERMINAL	2	
- 52	438568	. SCREW, MACH, UNDRCT BH, 6-32 X 1-1/8 ATT PT	4	
- 53	56722	. WASHER, LCKK, EXTERNAL TOOTH NO. 6 ATT PT	4	
- 54	257187	. NUT, PLAIN, HEX 6-32 ATT PT	4	
- 55	18735	. SPACER, SLV, 0.169 ID 3/8 OD 0.781 LG	4	
- 56	317157	. STRIP, TERMINAL	1	
- 57	317218	. TERMINAL BOARD, 10 SOLDER LUG TERM	2	
- 58	317156	. TERMINAL BOARD, 4 LUG TERMINALS	2	
- 59	317200	. TERMINAL BOARD, 8 LUG TERMINALS	1	
- 60	38235	. SCREW, MACH, BH, 6-32 X 0.312 LG ATT PT	12	
- 61	56722	. WASHER, LOCK, EXTERNAL TOOTH NO. 6 ATT PT	12	
- 62	257187	. NUT, PLAIN, HEX 6-32 ATT PT	12	
- 63	309758	. JUMPER ASSEMBLY	1	
- 64	115186	. . TERMINAL, LUG	1	
- 65	338911	. CAPACITOR, FREQUENCY SELECTION	1	
- 66	38235	. SCREW, MACH, BH, 6-32 X 0.312 LG ATT PT	2	
- 67	56722	. WASHER, LCKK, EXTERNAL TOOTH NO. 6 ATT PT	2	
- 68	257187	. NUT, PLAIN, HEX 6-32 ATT PT	2	
- 69	317520	. SOCKET, ELECTRON TUBE, 9 PIN	5	
- 70	338910	. CHASSIS	1	

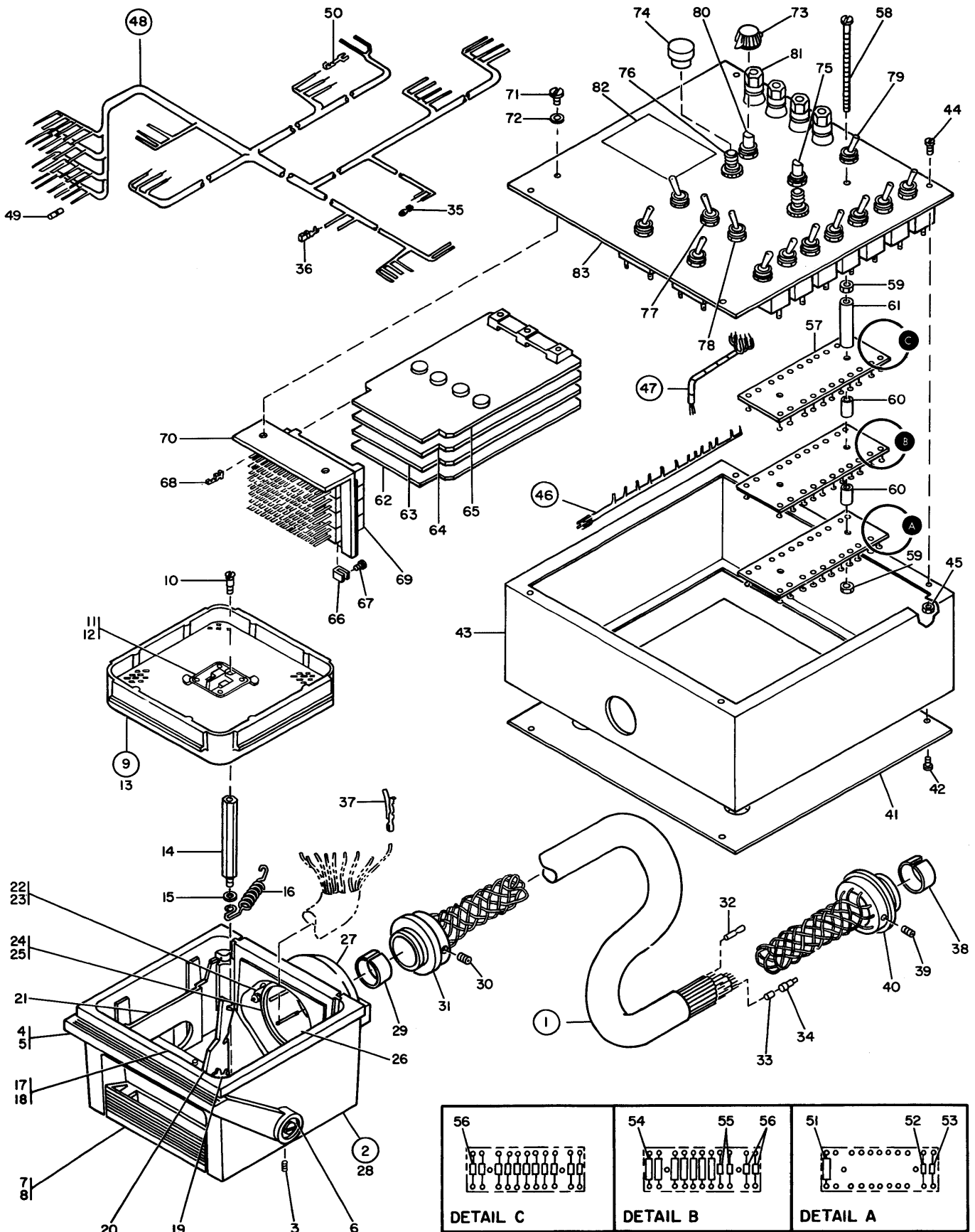

FIGURE 13. 7330 TAPE TESTER ASSEMBLY. SEE LIST 13.

TOOLS AND TEST

LIST AND INDEX NUMBER	PART NUMBER	DESCRIPTION	UNITS PER ASM.	USABLE ON CODE
		7330 TAPE TESTER ASSEMBLY		
13 -	461142	TESTER ASSEMBLY, TAPE, 7330 SEE FIGURE 13 FOR ILLUSTRATION	1	
- 1	556826	CABLE ASSEMBLY, MAIN TESTER	1	
- 2	558237	. . . CCNECTOR ASSEMBLY	1	
- 3	311546	. . . SCREW, SOCKET H, 10-32 X 1/4 LG	4	
- 4	5516C7	. . . HANDLE, LATCHING	1	
- 5	591747	. . . SCREW, RELIEVED BODY, SIOT H, 10-32 ATT PT	2	
- 6	591608	. . . INSERT, LATCHING HANDLE	1	
- 7	5516C9	. . . HANDLE, CARRIER	1	
- 8	223779	. . . SCREW, SELF-TAP, BH, NC. 8 X 1/2 LG ATT PT	2	
- 9	558253	. . . BOARD AND KEEPER PLATE ASSEMBLY	1	
- 10	551749	. . . SCREW, RELIEVED BCDY, SIOT H, 6-32 ATT PT	1	
- 11	55164C	. . . KEEPER, 200 PART OF BOARD & KEEPER PLATE	1	
- 12	591641	. . . SCREW, SHOULDER KEEPER PLATE MTG, 3.6-32 ATT PT	4	
- 13	558688	. . . BOARD, 200 OPEN WIRE LOW VOLTAGE CONN PART OF BOARD & KEEPER PLATE	1	
- 14	55175C	. . . STD, BOARD MOUNTING	1	
- 15	557575	. . . WASHER, FLAT, C.390 X 0.2180D X 0.045THK	1	
- 16	597578	. . . SPRING, LATCH CCNECTOR	1	
- 17	591746	. . . SHAFT, CAM	1	
- 18	1077739	. . . PIN, SPRING, 0.103 X 0.375 LG ATT PT	1	
- 19	251759	. . . RING, RETAINING	2	
- 20	551748	. . . LATCH, ROCK	1	
- 21	558241	. . . STANDOFF	2	
- 22	313289	. . . TERMINAL, LUG, NINS, 20AWG NO.10 MTG HOLE	1	
- 23	32454E	. . . NUT, HEX DOUBLE CHAMFER	1	
- 24	558240	. . . CLAMP	1	
- 25	558234	. . . SCREW, MACHINE, BH, 10-24 X 1-1/8 LG ATT PT	2	
- 26	558238	. . . COLLER	1	
- 27	55824E	. . . WHEEL, 90 DEGREE	1	
- 28	598256	. . . SHELL	1	
- 29	554282	. . . SLEEVE	1	
- 30	249080	. . . SCREW, SOCKET H, 8-32 X 1/4 LG ATT PT	1	
- 31	55694C	. . . RELIEF, STAIN	1	
- 32	523176	. . . CCNECTOR, TWO WAY, WIRE SIZE 24-20	16	
- 33	555725	. . . FERRULE, INNER	7	
- 34	555726	. . . TERMINATOR	7	
- 35	334932	. . . TERMINAL, RING, 18-22 AWG, #10 HOLE, INS	1	
- 36	216265	. . . TERMINAL, QUICK DISCCN, NCN-INS, 20AWG	6	
- 37	558041	. . . SOCKET CONTACT	30	
- 38	554282	. . . SLEEVE	1	
- 39	249080	. . . SCREW, SOCKET H, 8-32 X 1/4 LG ATT PT	1	
- 40	55694C	. . . RELIEF, STAIN	1	
- 41	556933	. . . PANEL, REAR	1	
- 42	70078	. . . SCREW, SELF-TAP, PAN HD, 6-32 X 1/4 LG ATT PT	4	
- 43	556934	. . . CASE, FIELD TESTER	1	
- 44	58207	. . . SCREW, MACH, UNDRCT BH, 8-32 X 1/4 LG ATT PT	4	
- 45	257189	. . . NUT, HEX, 8-32 ATT PT	4	
- 46	5323472	. . . CABLE ASSEMBLY	1	
- 47	5323473	. . . CABLE ASSEMBLY	1	
- 48	5323474	. . . CABLE ASSEMBLY	1	
- 49	216265	. . . TERMINAL, QUICK DISCCN, NCN-INS, 20AWG	25	
- 50	186967	. . . TERMINAL, SPADF, 20-24 AWG, #6 HOLE, NINS	3	



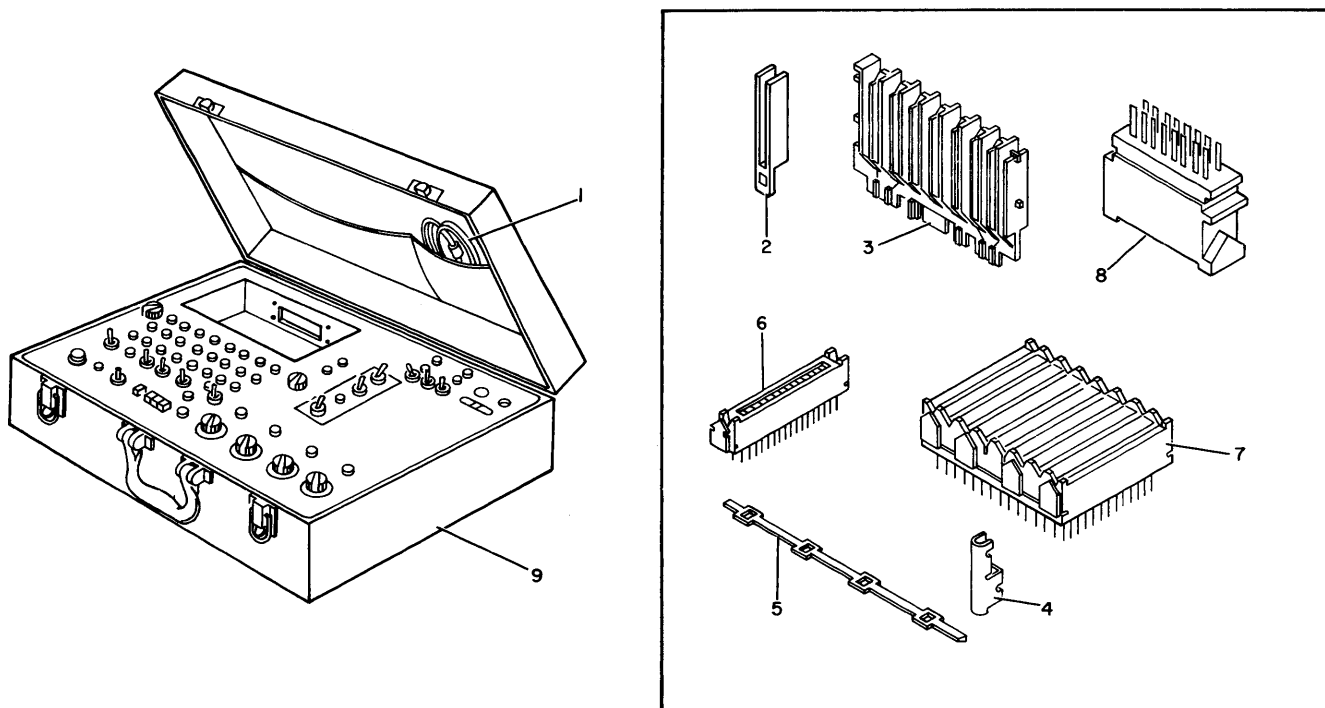

FIGURE 14. OFFLINE SELECTRIC ANALYZER ASSEMBLY. SEE LIST 14.

LIST AND INDEX NUMBER	PART NUMBER	DESCRIPTION				UNITS PER ASM.	USABLE ON CODE
		1	2	3	4		
		OFFLINE SELECTRIC ANALYZER ASSEMBLY					
14 -	99C0385					1	
- 1	113243E					1	
- 2	216206					2	
- 3	216085					1	
- 4	216265					12	
- 5	212822					24	
- 6	21607E					2	
- 7	216083					1	
- 8	737916					1	
- 9	544281C					1	

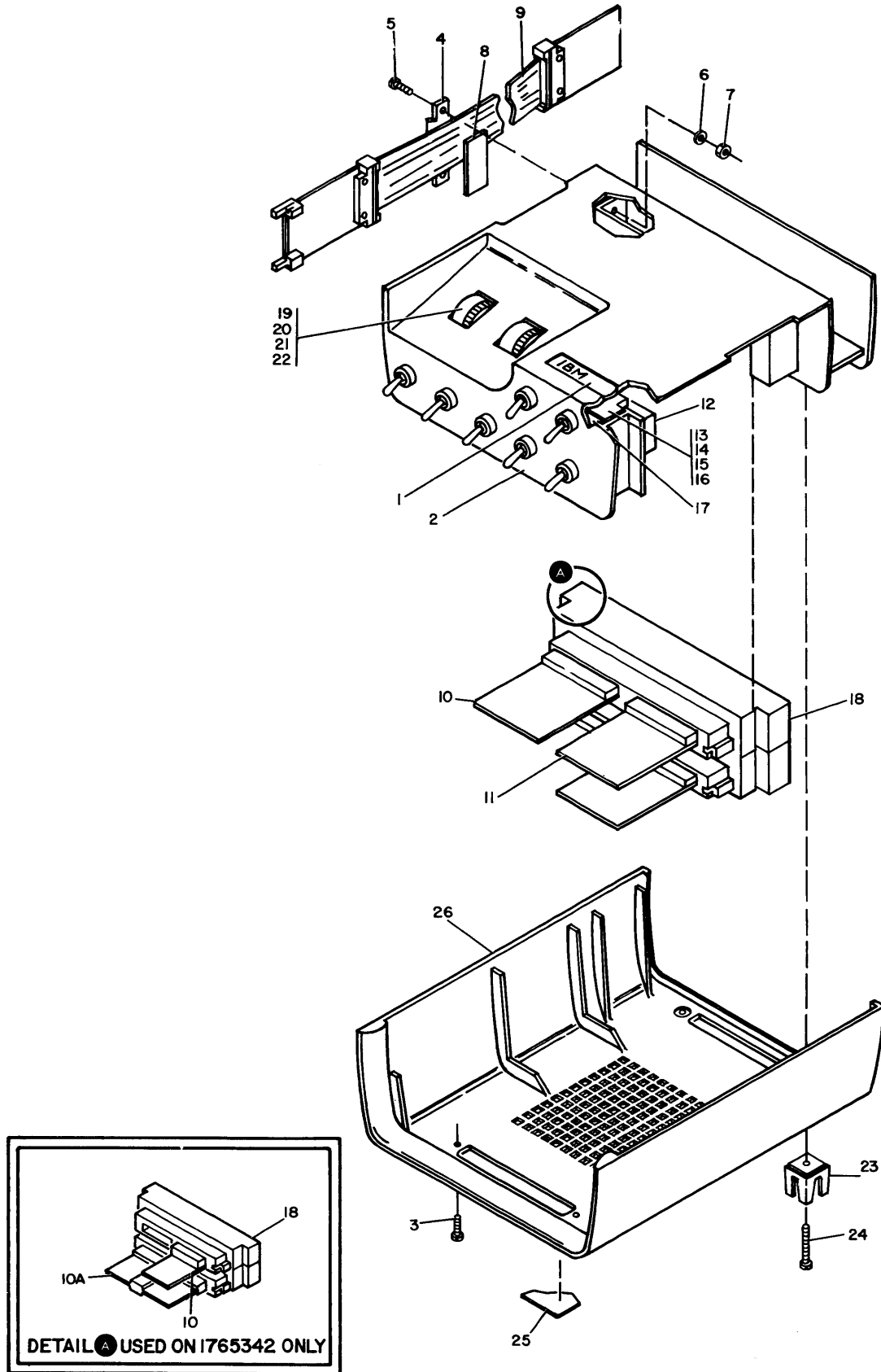

FIGURE 15. FIELD TESTER ASSEMBLY. SEE LIST 15.

TOOLS AND TEST

LIST AND INDEX NUMBER	PART NUMBER	DESCRIPTION	UNITS PER ASM.	USABLE ON CODE
		FIELD TESTER ASSEMBLY		
15 -		CODE A USED ON TESTER ASM 2513300 2420 CODE B USED ON TESTER ASM 1765342 2420/3420		
-	2513300	TESTER ASSEMBLY, FIELD	1	
-	1765342	TESTER ASSEMBLY, FIELD	1	
		SEE FIGURE 15 FOR ILLUSTRATION		
- 1	2513320	. NAMEPLATE	1	A
- 1	1765352	. NAMEPLATE	1	B
- 2	2513305	. FACEPLATE	1	A
- 2	1765360	. FACEPLATE	1	B
- 3	81693	. SCREW, MACH, BH, 6-32 X 3/8 LG ATT PT	2	
- 4	2513308	. CLAMP	1	
- 5	35739	. SCREW, MACH, BH, 6-32 X 15/16 LG ATT PT	AR	
- 5	438549	. SCREW, BIND HD- 4-40 X 7/16 LG ATT PT	AR	
- 6	56722	. WASHER, LCKK, EXTERNAL TOOTH NO. 6 ATT PT	AR	
- 6	338169	. WASHER, LOCK, EXT T- NO.4 ATT PT	AR	
- 7	257187	. NUT, FLAIN, HEX 6-32 ATT PT	AR	
- 7	37913	. NUT, HEX- 4-40 ATT PT	AR	
- 8	2513307	. SPACER	1	
- 9	2513316	. CABLE ASSEMBLY, EXTERNAL	1	A
- 9	5802144	. CABLE ASSEMBLY, EXTERNAL	1	B
- 10	5808281	. CARD	1	A
- 10	8216712	. CARD	1	B
- 10A	811364	. GUIDE, CARD	1	B
- 11	5808301	. CARD	1	A
- 12	2513327	. RETAINER	1	
- 13	2513315	. BOARD ASSEMBLY, SWT	1	A
- 13	1175350	. BOARD ASSEMBLY, SWT	1	B
- 14	251970	. SCREW, MACH, BS H, 4-40 X 0.250 LG ATT PT	3	
- 15	257985	. WASHER, FL NO.4 X 0.250 OD X 0.028 THK ATT PT	3	
- 16	257984	. WASHER, LOCK, SPLIT, 1/8 ID X 13/64 OD ATT PT	3	
- 17	2513301	. SPACER	1	
- 18	2513321	. BOARD ASSEMBLY	1	
- 19	2513323	. POT ASSEMBLY, BLCCK	1	
- 20	438550	. SCREW, MACH, BH, 4-40 X 1/2 LG ATT PT	1	
- 21	257985	. WASHER, FL NO.4 X 0.250 CD X 0.028 THK ATT PT	1	
- 22	257984	. WASHER, LCKK, SPLIT, 1/8 ID X 13/64 OD ATT PT	1	
- 23	2513302	. PAD	2	
- 24	322550	. SCREW, MACH, BH, 6-32 X 1/2 LG ATT PT	2	
- 25	813769	. DECAL	1	B
- 26	2513304	. BASE	1	A
- 26	1765361	. BASE	1	B



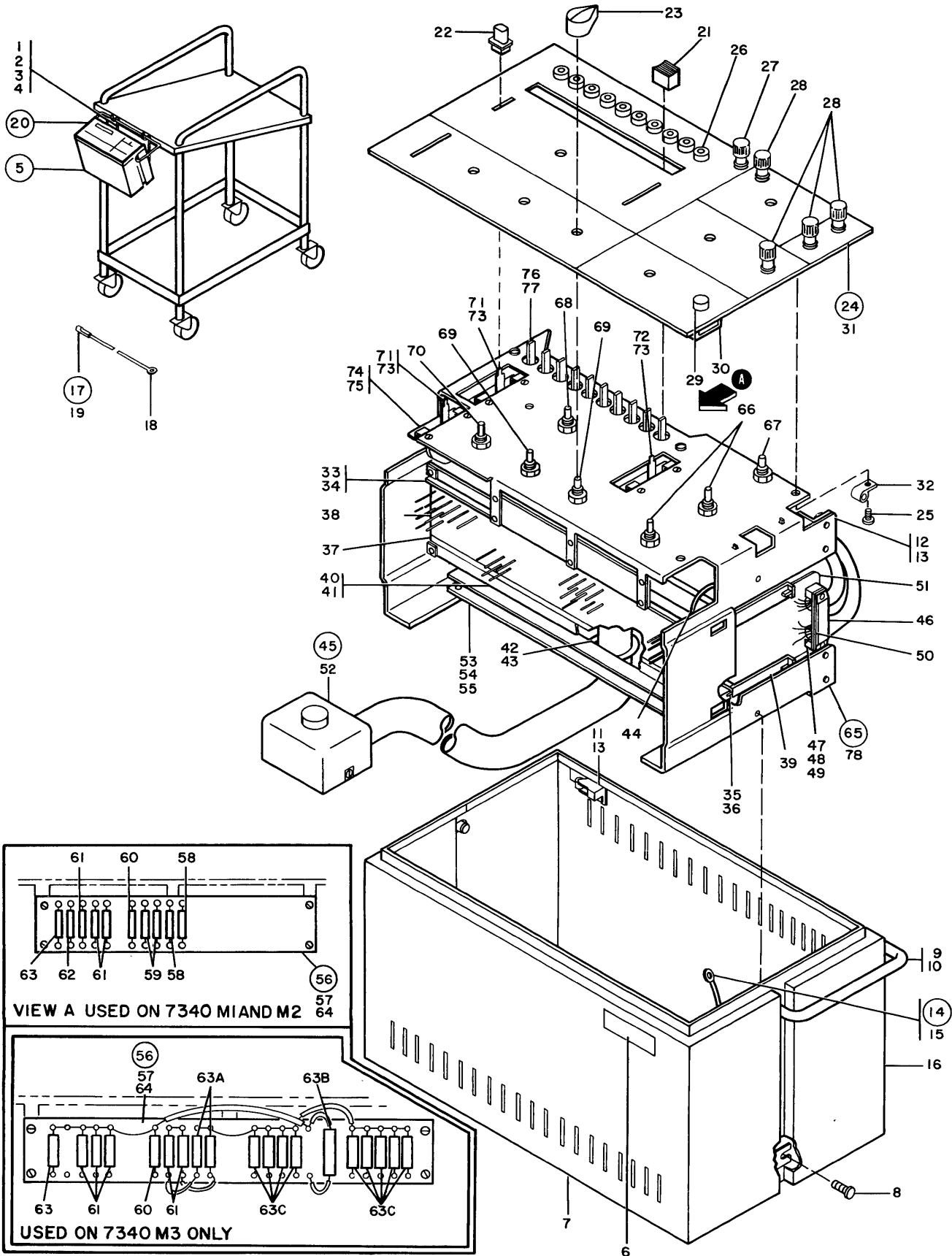

FIGURE 16. FUNCTIONAL TESTERS 7340M1, 7340M2 AND 7340M3. SEE LIST 16.

TOOLS AND TEST

LIST AND INDEX NUMBER	PART NUMBER	DESCRIPTION	UNITS PER ASM.	USABLE ON CODE
		1 2 3 4		
		FUNCTIONAL TESTERS 7340M1, 7340M2 AND 7340M3		
16 -		CODE A USED CN 7340M1 AND 7340M2 CODE B USED CN 7340M3		
-	461222	TESTER, FUNCTIONAL-7340M1 AND 7340M2	1	A
-	461445	TESTER, FUNCTIONAL-7340M3	1	B
		SEE FIGURE 16 FOR ILLUSTRATION		
- 1	461209	. BRACKET, TESTER MOUNTING	1	
- 2	568	. SCREW, MACH, RH, 10-32 X 1/2 LG ATT PT	3	
- 3	9092	. WASHER, LOCK, SPLIT RING, 0.194ID 0.3370 ATT PT	3	
- 4	11598	. NUT, PLAIN, HEX, 10-32 X 3/8 FL W ATT PT	3	
- 5	461204	. COVER ASSEMBLY	1	
- 6	461212	. . . NAMEPLATE	2	
- 7	461218	. . . COVER, LOWER	1	
- 8	236849	. . . SCREW, MACHINE, BH, 10-32 X 1/4 LG ATT PT	4	
- 9	461219	. . . HANDLE	1	
- 10	257982	. . . CLIP, RETAINING, E TYPE C.188 DIA GROOVE ATT PT	3	
- 11	513668	. . . CATCH, FRICTION LATCH	4	
- 12	513669	. . . STRIKE, FRICTION LATCH	4	
- 13	55726	. . . SCREW, MACH, BH, 6-32 X C.188 LG ATT PT	16	
- 14	535964	. . . JUMPER ASSEMBLY, GRN, 10 IN LG 14AWG	1	
- 15	359695	. . . TERMINAL, RING, 14-16 AWG, NO.10 HOLE INS	2	
- 16	461220	. . . COVER, UPPER	1	
- 17	531216C	. . . JUMPER ASSEMBLY	1	
- 18	186961	. . . TERMINAL, RING, NO. 6 STUD, NONINSULATED	1	
- 19	591047	. . . TERMINAL, SLIP CN, 18-16 AWG	1	
- 20	461201	. . . FRAME ASSEMBLY, FUNCTIONAL TESTER	1	A
- 20	461444	. . . FRAME ASSEMBLY, FUNCTIONAL TESTER	1	B
- 21	532429	. . . BUTTON, SELECTOR SWITCH	10	
- 22	5312194	. . . BUTTON, PUSH, OVAL	3	
- 23	5312196	. . . KNOB, ROTARY	7	
- 24	461202	. . . PANEL ASSEMBLY, DISPLAY	1	A
- 24	461438	. . . PANEL ASSEMBLY, DISPLAY	1	B
- 25	32042	. . . SCREW, MACH, BH, 10-32 X 3/8 LG ATT PT	4	
- 26	321397	. . . JACK	10	
- 27	5312176	. . . BINDING POST, BLACK	1	
- 28	5312169	. . . PCST	4	
- 29	5312193	. . . ADAPTER, PUSHBUTTON GUARDED	1	
- 30	365047	. . . SWITCH, PUSH, SEDT 125VAC 1 AMP	1	
- 31	461215	. . . PANEL, CEM DISPLAY	1	
- 31	461436	USED CN 461202 7340M1 AND 7340M2 . . . PANEL, CEM DISPLAY	1	
- 32	515661	USED ON 461438 7340M3 . . . CLAMP, LOCK, 3/8 ID 0.204 DIA MTG HOLE	2	
- 33	5312299	. . . T-BAR	1	
- 34	438548	. . . SCREW, MACH, BH, 4-40 X 3/16 LG ATT PT	2	
- 35	216091	. . . ADAPTER, CARD GUIDE	6	
- 36	38264	. . . SCREW, MACH, FTH, 4-40 X 3/8 LG ATT PT	9	
- 37	216285	. . . LABEL, NUMBERING L TC R 1 THRU 28	1	
- 38	461205	. . . CARD RECEPTACLE	1	A
- 38	461443	. . . CARD RECEPTACLE	1	B
- 39	216231	. . . GUIDE, CARD, 8 PCS	6	
- 40	5312181	. . . T-BAR	1	
- 41	38433	. . . SCREW, MACH, FH, 4-40 X 1/4 LG ATT PT	2	
- 42	5312183	. . . CLAMP, CABLE	1	
- 43	11598	. . . NUT, PLAIN, HEX, 10-32 X 3/8 FL W ATT PT	2	
- 44	461207	. . . CABLE	1	A
- 44	461440	. . . CABLE	1	B
- 45	461206	. . . CABLE ASSEMBLY	1	A
- 45	461441	. . . CABLE ASSEMBLY	1	B
- 46	216208	. . . CLAMP, CABLE CONNECTOR	5	
- 47	216209	. . . SUPPORT, CABLE CONNECTOR CARD	5	
- 48	338238	. . . SCREW, MACH, BH, 4-40 NC X 0.3125 LG ATT PT	15	
- 49	1103744	. . . WASHER, SPRING TENS, 0.126 ID X 0.281 OD ATT PT USED ON 461206 7340M1 AND 7340M2	15	
- 50	216210	. . . SPACER, CABLE CONNECTOR ATT PT	5	
- 51	491349	. . . CARD ASSEMBLY ATT PT	5	
- 52	591752	. . . CONNECTOR ASSEMBLY	1	
- 52	5356057	USED CN 461206 7340M1 AND 7340M2 . . . CONNECTOR	1	
- 53	461214	USED CN 461441 7340M3 . . . BRACKET, CABLE MOUNTING	1	
- 54	236849	. . . SCREW, MACHINE, BH, 10-32 X 1/4 LG ATT PT	2	
- 55	45690	. . . WASHER, FL, NC.10 X 7/16 OD X 1/32 THK ATT PT	2	



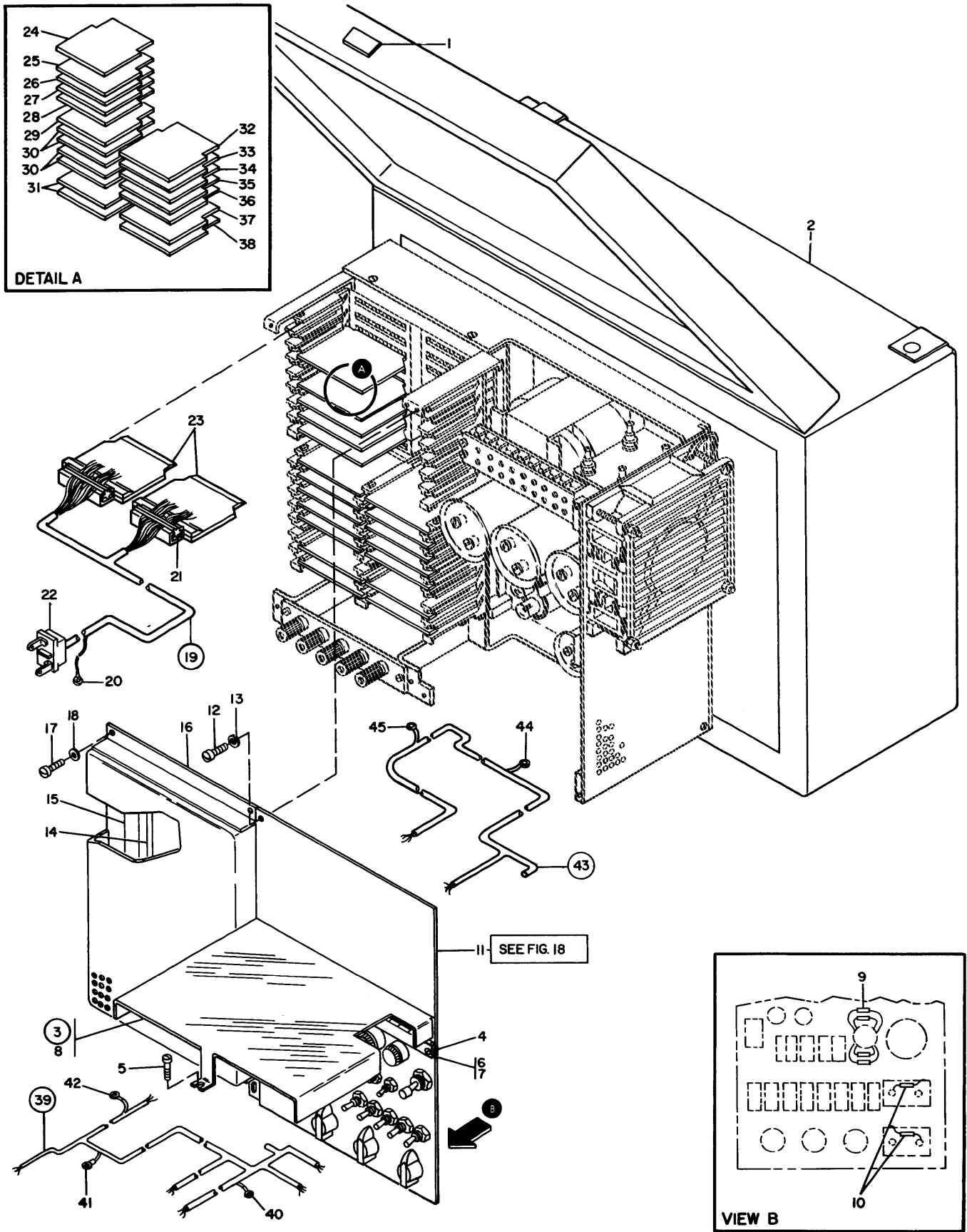

FIGURE 17. COMMUNICATIONS SYSTEM SIMULATOR. SHEET 1 OF 2. INDEX NOS. 1-45. SEE LIST 17.

TOOLS AND TEST

LIST AND INDEX NUMBER	PART NUMBER	DESCRIPTION				UNITS PER ASM.	USABLE ON CODE
		1	2	3	4		
		COMMUNICATIONS SYSTEM SIMULATOR					
17 -	452394	SIMULATOR, COMMUNICATIONS SYSTEM SEE FIGURE 17 FOR ILLUSTRATION				1	
- 1	743033	. NAMEPLATE				1	
- 2	822676	. CASE				1	
- 3	822698	. COVER ASSEMBLY				1	
- 4	81693	. SCREW, MACH, BH, 6-32 X 3/8 LG				2	ATT PT
- 5	55726	. SCREW, MACH, BH, 6-32 X 0.188 LG				1	ATT PT
- 6	822697	. . HINGE				1	
- 7	438566	. . SCREW, MACH, BH, 6-32 X 0.125 LG				3	ATT PT
- 8	822696	. . COVER, PANEL				1	
- 9	479128	. RESISTOR, FILM, 3.01K, 1%, 0.125W				4	
- 10	2106333	. SEMICONDUCTOR DEVICE				2	
- 11	822677	. PANEL ASSEMBLY SEE LIST 18 FOR DETAIL BREAKDOWN				1	
- 12	38235	. SCREW, MACH, BH, 6-32 X 0.312 LG				4	ATT PT
- 13	56722	. WASHER, LOCK, EXTERNAL TOOTH NO. 6				4	ATT PT
- 14	475465	. SEAL, COVER				AR	
- 15	301356	. STRIP, SEALING				AR	
- 16	822681	. COVER, CHASSIS				1	
- 17	10170	. SCREW, MACH, BH, 6-32 X 1/4 LG				4	ATT PT
- 18	257986	. WASHER, FLAT, NO. 6 X 0.312 OD				4	ATT PT
- 19	822654	. CABLE ASSEMBLY				1	
- 20	596255	. . TERMINAL, SIIP ON, 24-20 AWG				1	
- 21	216300	. . PLUG, STRAIN RELIEF				2	
- 22	195000	. . CONNECTOR, LAMP, 2 PIN				1	
- 23	216304	. . STRAIN RELIEF				2	
- 24	372826	. CARD ASSEMBLY, HFY				1	
- 25	373485	. CARD ASSEMBLY, EDD				1	
- 26	373486	. CARD ASSEMBLY, EEE				1	
- 27	374143	. CARD ASSEMBLY, UFK				1	
- 28	374133	. CARD ASSEMBLY, UGY				1	
- 29	372718	. CARD ASSEMBLY, YYG				1	
- 30	372006	. CARD ASSEMBLY, YZY				4	
- 31	370262	. CARD ASSEMBLY, DHE				2	
- 32	372737	. CARD ASSEMBLY, ZTP				1	
- 33	372016	. CARD ASSEMBLY, ZCK				1	
- 34	372009	. CARD ASSEMBLY, ZQB				1	
- 35	372010	. CARD ASSEMBLY, ZQC				1	
- 36	371501	. CARD ASSEMBLY, GJ				1	
- 37	372610	. CARD ASSEMBLY, ZKZ				1	
- 38	372008	. CARD ASSEMBLY, ZQA				1	
- 39	822655	. CABLE ASSEMBLY				1	
- 40	596255	. . TERMINAL, SIIP ON, 24-20 AWG				3	
- 41	334768	. . TERMINAL, RING, 16-22 AWG 1/4 MTG HOLE				10	
- 42	334921	. . TERMINAL, RING, 18-22 AWG, #6 HOLE, INS				8	
- 43	822656	. CABLE ASSEMBLY				1	
- 44	92784	. . TERMINAL, RING, 18-22 AWG, NO.8 HOLE, INS				7	
- 45	334921	. . TERMINAL, RING, 18-22 AWG, #6 HOLE, INS				1	

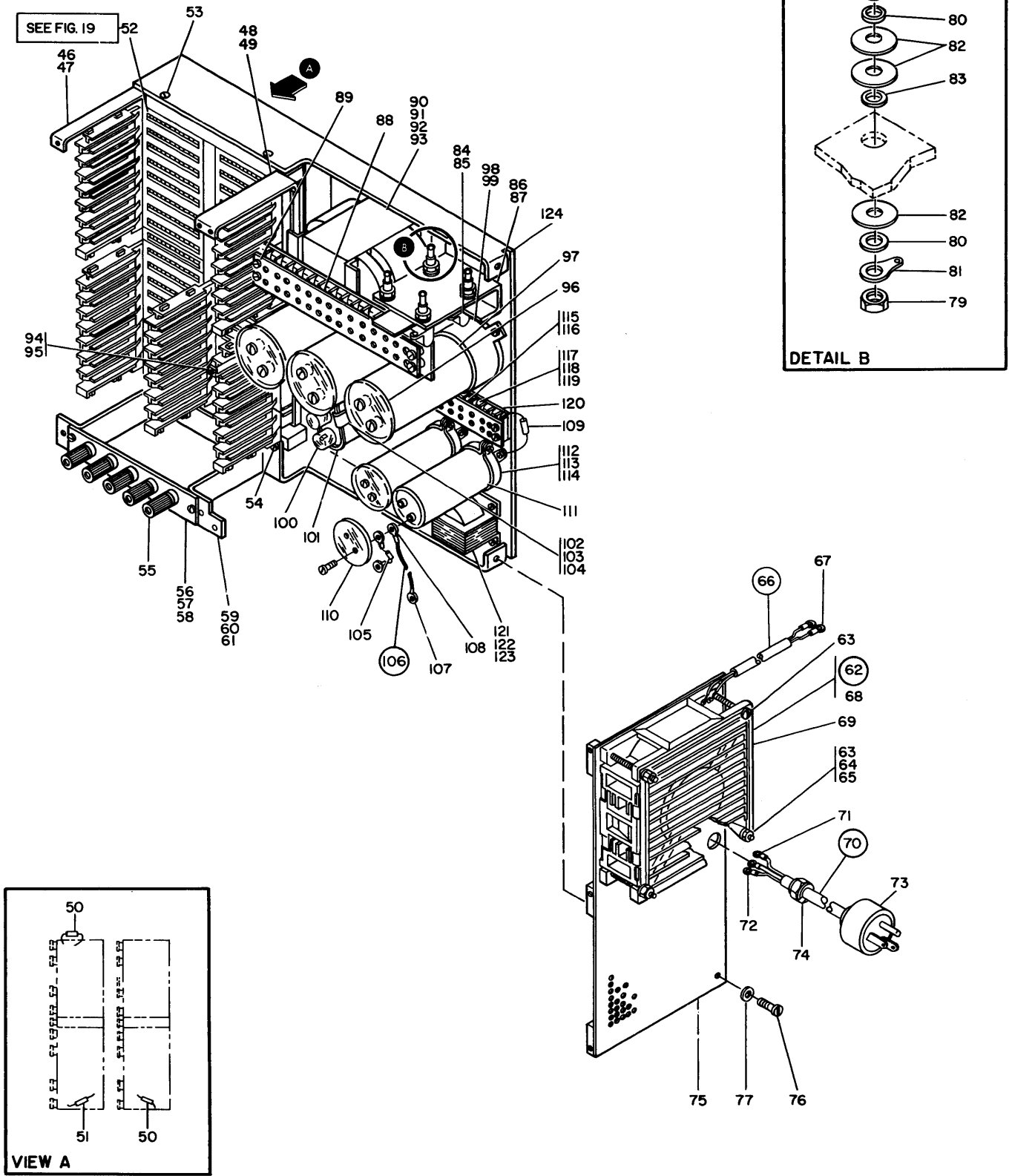

FIGURE 17. COMMUNICATIONS SYSTEM SIMULATOR. SHEET 2 OF 2. INDEX NOS. 46-124. SEE LIST 17.

TOOLS AND TEST

LIST AND INDEX NUMBER	PART NUMBER	DESCRIPTION	UNITS PER ASM.	USABLE ON CODE
17 - 46	822684	. BRACKET, COVER, SUPPORT	1	
- 47	443	. SCREW, MACH, FIL H, 10-32 X 3/8 LG ATT PT	1	
- 48	822683	. BRACKET, COVER, SUPPORT	1	
- 49	3838C	. SCREW, MACH, FIL H, 10-32 X 1/4 LG ATT PT	1	
- 50	210967	. CAPACITOR ASSEMBLY, 16PF	2	
- 51	822661	. RESISTOR ASSEMBLY	1	
- 52	822678	. CHASSIS ASSEMBLY	1	
- 53	49814	SEE LIST 19 FOR DETAIL BREAKDOWN		
- 54	32617	. SCREW, MACH, FH, 10-32 X 7/16 LG ATT PT	1	
- 55	450954	. SCREW, MACH, BH, 10-32 X 0.438 LG ATT PT	2	
- 56	822692	. POST, BINDING	5	
- 57	10170	. PLATE, MOUNTING	1	
- 58	257986	. SCREW, MACH, BH, 6-32 X 1/4 LG ATT PT	2	
- 59	822688	. WASHER, FLAT, NC. 6 X 0.312 OD ATT PT	2	
- 60	28413	. BRACKET, MOUNTING	1	
- 61	4569C	. SCREW, MACH, BH, 10-32 X 5/16 LG ATT PT	2	
- 62	822671	. WASHER, FL, NC.10 X 7/16 CD X 1/32 THK ATT PT	2	
- 63	438572	. FAN ASSEMBLY	1	
- 64	257986	. SCREW, MACH, UNDRCT BH, 6-32 X 2 LG ATT PT	4	
- 65	257187	. WASHER, FLAT, NC. 6 X 0.312 OD ATT PT	3	
- 66	520539	. NUT, PLAIN, HEX 6-32	3	
- 67	334921	. . JUMPER ASSEMBLY	2	
- 68	527300	. . . TERMINAL, RING, 18-22 AWG,#6 HOLE, INS	1	
- 69	177946	. . . FAN, AXIAL, 115V AC 1PH 60 HZ	1	
- 70	822659	. GUARD, FAN	1	
- 71	334768	. AC COORD ASSEMBLY	1	
- 72	334921	. . . TERMINAL, RING, 16-22 AWG 1/4 MTG HOLE	1	
- 73	256341	. . . TERMINAL, RING, 18-22 AWG,#6 HOLE, INS	2	
- 74	107611	. . . PLUG, GROUNDED COMMERCIAL, 125V 15A	1	
- 75	822687	. BUSHING	1	
- 76	55726	. COVER, SIDE	1	
- 77	56722	. SCREW, MACH, BH, 6-32 X 0.188 LG ATT PT	1	
- 78	558479	. WASHER, LOCK, EXTERNAL TCCTH NO. 6 ATT PT	1	
- 79	11598	. SEMICONDUCTOR DEVICE, DIODE, 150V 10A	4	
- 80	45690	. NUT, FLAIN, HEX, 10-32 X 3/8 FL W ATT PT	4	
- 81	316996	. WASHER, FL, NO.10 X 7/16 CD X 1/32 THK ATT PT	8	
- 82	217019	. TERMINAL, LUG, NINS, 9AWG NO. 8 MTG HOLE	4	
- 83	473582	. WASHER, INSULATING	8	
- 84	5240459	. INSULATOR	4	
- 85	25197C	. RESISTOR, FIXED, 25 OHM 25W	2	
- 86	822689	. SCREW, MACH, BS H, 4-40 X 0.250 LG ATT PT	4	
- 87	58207	. BRACKET, MOUNTING	1	
- 88	187470	. SCREW, MACH, UNDRCT BH, 8-32 X 1/4 LG ATT PT	2	
- 89	210984	. SHIELD, TERMINAL BOARD	1	
- 90	5240455	. SCREW, MACH, RD HD, 6-32 X 0.250LG ATT PT	1	
- 91	28413	. TRANSFORMER, 60 HZ	1	
- 92	56C79	. SCREW, MACH, BH, 10-32 X 5/16 LG ATT PT	4	
- 93	4569C	. WASHER, LOCK, EXT TEETH, 0.195ID 0.410OD ATT PT	4	
- 94	822685	. WASHER, FL, NO.10 X 7/16 OD X 1/32 THK ATT PT	4	
- 95	38380	. BRACKET, MOUNTING	1	
- 96	750342	. SCREW, MACH, FIL H, 10-32 X 1/4 LG ATT PT	1	
- 97	208224	. COVER, CAPACITOR	3	
- 98	320456	. CAPACITOR, FXD ELECT, 14KMF D P150M10%13V	3	
- 99	58207	. BRACKET, CAPACITOR MOUNTING	3	
- 100	526378	. SCREW, MACH, UNDRCT BH, 8-32 X 1/4 LG ATT PT	9	
- 101	5240458	. INSULATION	1	
- 102	621446	. CAPACITOR, PAPER, 5MED P/M 6% 330VAC	1	
- 103	337	. CLAMP	2	
- 104	1050873	. SCREW, MACH, FIL H, 8-32 X 3/8 LG ATT PT	2	
- 105	629576	. WASHER, LOCK, SPLIT RING, 0.168ID, 0.296OD ATT PT	2	
- 106	822695	. RESISTOR ASSEMBLY	2	
- 107	334768	. JUMPER ASSEMBLY	1	
- 108	334921	. . . TERMINAL, RING, 16-22 AWG 1/4 MTG HOLE	1	
- 109	737806	. . . TERMINAL, RING, 18-22 AWG,#6 HOLE, INS	1	
- 110	361503	. CAPACITOR ASM	2	
- 111	483107	. COVER, CAPACITOR	2	
- 112	301750	. CAPACITOR, 3100MFD	2	
- 113	58207	. CLAMP, RETAINING-CAPACITOR	2	
- 114	60646	. SCREW, MACH, UNDRCT BH, 8-32 X 1/4 LG ATT PT	4	
- 115	191480	. WASHER, LOCK, INT TEETH, NO. 8 ATT PT	4	
- 116	210984	. SHIELD, 8 POSITION	1	
- 117	322766	. SCREW, MACH, RD HD, 6-32 X 0.250LG ATT PT	1	
- 118	210884	. BLOCK, TERMINAL	1	
- 119	210883	. STUD, SHIELD MOUNTING, NO. 6-32 ATT PT	1	
- 120	322267	. STUD, SHIELD MTG, TAPPED, NO. 6-32 ATT PT	3	
- 121	629577	. MARKER STRIP, 8 POS NOS. 1 THRU 8	1	
- 122	58207	. CHOKE ASSEMBLY	2	
- 123	60646	. SCREW, MACH, UNDRCT BH, 8-32 X 1/4 LG ATT PT	8	
- 124	822680	. WASHER, LOCK, INT TEETH, NC. 8 ATT PT	8	
		. CHASSIS	1	

FOR PARTS  
NOT SHOWN  
SEE FIG. 17

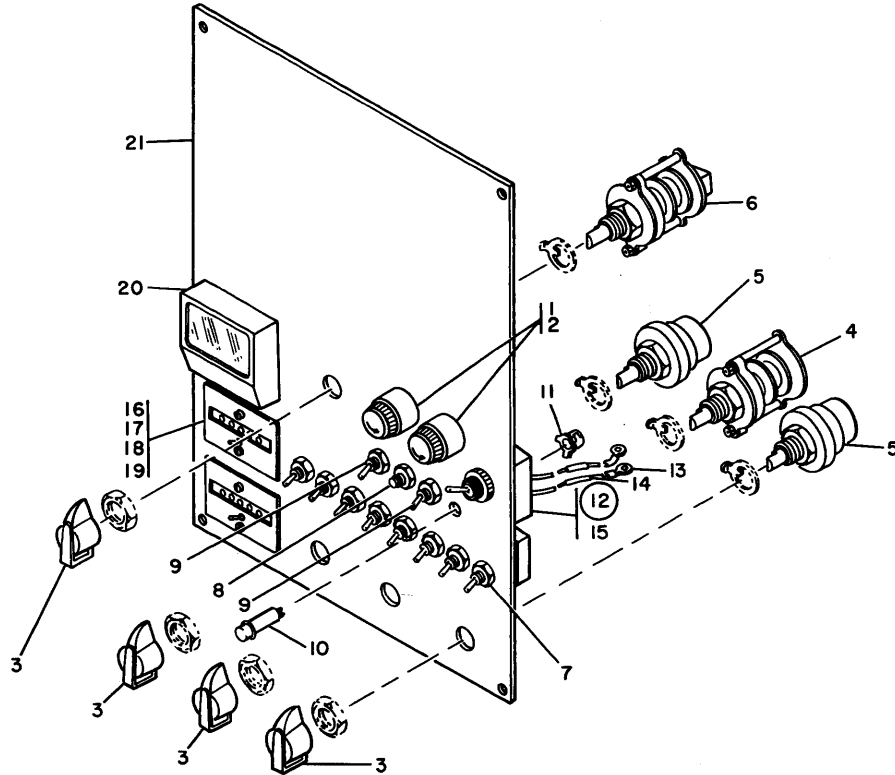

FIGURE 18. CONTROL PANEL ASSEMBLY. SEE LIST 18.

LIST AND INDEX NUMBER	PART NUMBER	DESCRIPTION				UNITS PER ASM.	USABLE ON CODE
		1	2	3	4		
		CONTRCL PANEL ASSEMBLY					
18 -	822677	CONTRCL PANEL ASSEMBLY SEE LIST 17-11 FOR NEXT HIGHER ASSEMBLY AND FIG. 18 FOR ILLUSTRATION				REF	
- 1	78952	. FUSE, CART, TIME DELAY, 250V 0.8A				2	
- 2	178946	. HOLDER, FUSE				2	
- 3	317173	. KNOB, BAR TYPE WITH POINTER				4	
- 4	741861	. SWITCH, ROTARY, 5 POSITION				1	
- 5	724485	. SWITCH, ROTARY, 3 POSITION				2	
- 6	82267C	. SWITCH, ROTARY, TRANSCHEMER				1	
- 7	36504E	. SWITCH, SENSITIVE SPDT				8	
- 8	365047	. SWITCH, PUSH, SPDT 125VAC 1 AMP				1	
- 9	368164	. SWITCH, TCGGLE, DPDT				2	
- 10	550511	. LAMP, INCANDESCENT, 10V 14 MA				1	
- 11	368168	. CLIP, SPEED				1	
- 12	822675	. SWITCH ASSEMBLY				1	
- 13	334921	. . TERMINAL, RING, 18-22 AWG, #6 HOLE, INS				2	
- 14	347181	. . TERMINAL, QUICK DISCONNECT				2	
- 15	755435	. . SWITCH, TCGGLE, DEST				1	
- 16	822650	. COUNTER, IMPULSE				2	
- 17	288	. SCREW, MACH, FL CSK H, 3-48 X 1/4 LG				4	ATT PT
- 18	1091111	. WASHER, LOCK, INT TEETH NO. 3 X 0.225 OD				4	ATT PT
- 19	8506	. NUT, FLAIN, HEX, 3-48 X 3/16 FL W				4	ATT PT
- 20	822653	. METER				1	
- 21	822682	. PANEL, CONTRCL				1	



FOR PARTS  
NOT SHOWN  
SEE FIG. 17

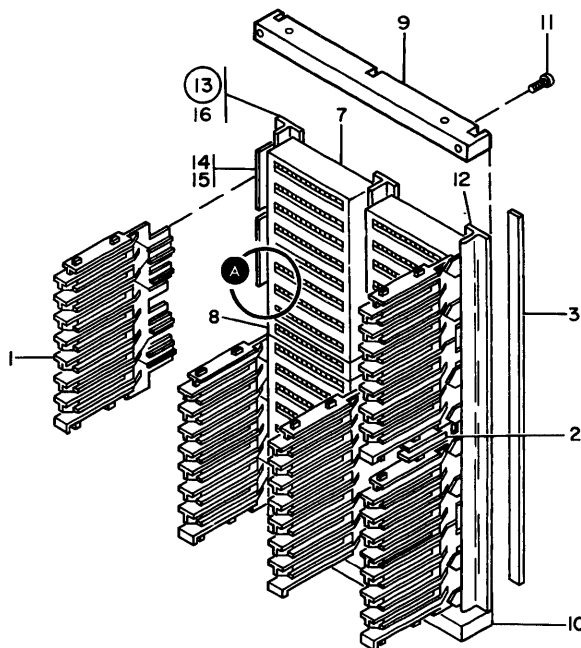
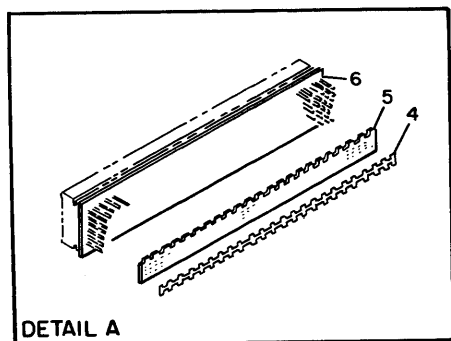

FIGURE 19. CHASSIS ASSEMBLY. SEE LIST 19.

LIST AND INDEX NUMBER	PART NUMBER	DESCRIPTION				UNITS PER ASM.	USABLE ON CODE
		1	2	3	4		
		CHASSIS ASSEMBLY					
19 -	822678	CHASSIS ASSEMBLY SEE LIST 17-52 FOR NEXT HIGHER ASSEMBLY AND FIG. 19 FOR ILLUSTRATION				REF	
- 1	216085	. GUIDE, CARD, 8 POSITION LONG				5	
- 2	216206	. GUIDE, SINGLE CARD LONG				1	
- 3	216285	. LABEL, NUMBERING 1 TO R 1 THRU 28				3	
- 4	212822	. BUS BAR, CHAIN VOLTAGE				AR	
- 5	216266	. INSULATOR, PLATE, BACK PANEL, 26 POS				2	
- 6	212775	. CARD, BACK PANEL, 26 POSITION				2	
- 7	216083	. CARD RECEPTACLE ASSEMBLY				4	
- 8	216076	. TERMINAL BLOCK AND CONTACT ASSEMBLY				2	
- 9	822691	. BAR, MOUNTING, REAR				1	
- 10	822690	. BAR, MOUNTING, FRONT				1	
- 11	10170	. SCREW, MACH, BH, 6-32 X 1/4 LG				6	ATT PT
- 12	822686	. T-BAR				2	
- 13	822679	. ADAPTER ASSEMBLY				1	
- 14	216091	. . ADAPTER, CARD GUIDE				2	
- 15	38264	. . SCREW, MACH, FIL H, 4-40 X 3/8 LG				4	ATT PT
- 16	822693	. . T-BAR, ADAPTER				1	

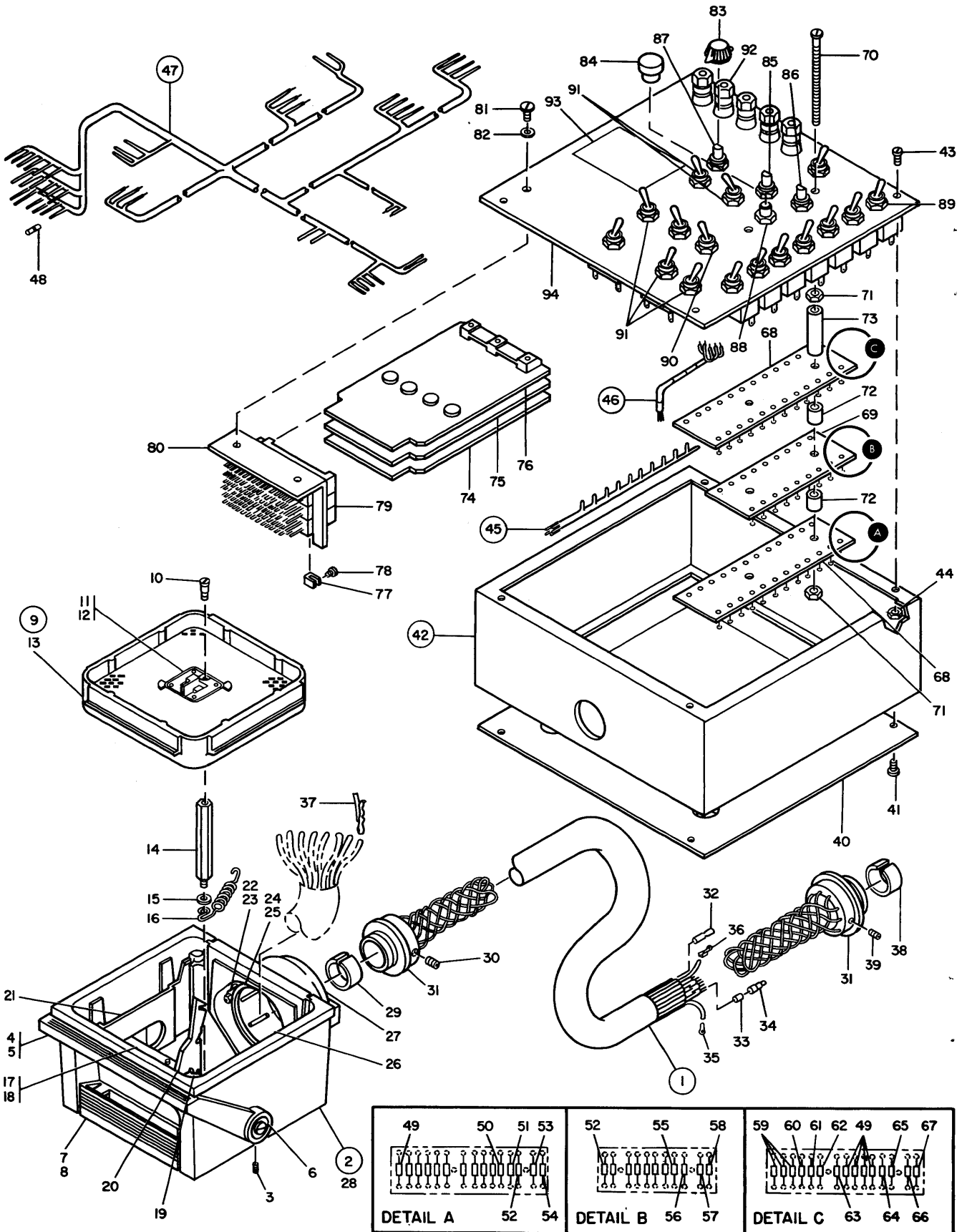

FIGURE 20. 729/7330 FIELD TESTER ASSEMBLY. SEE LIST 20.

TOOLS AND TEST

LIST AND INDEX NUMBER	PART NUMBER	DESCRIPTION				UNITS PER ASM.	USABLE ON CODE
		1	2	3	4		
		729/7330 FIELD TESTER ASSEMBLY					
20 -	461390	TESTER ASSEMBLY, FIELD, 729/7330 SEE FIGURE 20 FOR ILLUSTRATION				1	
- 1	5344924	. CABLE ASSEMBLY, MAIN TESTER				1	
- 2	598237	. . . CCNNECTOR ASSEMBLY				1	
- 3	311546	. . . SCREW, SOCKET H, 10-32 X 1/4 LG				4	
- 4	551607	. . . HANDLE, LATCHING				1	
- 5	591747	. . . SCREW, RELIEVED BODY, SLOT H, 10-32 ATT PT				2	
- 6	591608	. . . INSERT, LATCHING HANDLE				1	
- 7	551609	. . . HANDLE, CARRIER				1	
- 8	223779	. . . SCREW, SELF-TAP, BH, NO. 8 X 1/2 LG ATT PT				2	
- 9	598253	. . . BOARD AND KEEPER PLATE ASSEMBLY				1	
- 10	551749	. . . SCREW, RELIEVED BODY, SLOT H, 6-32 ATT PT				1	
- 11	591640	. . . KEEPER, 200 PART OF BOARD & KEEPER PLATE				1	
- 12	591641	. . . SCREW, SHOULDER KEEPER PLATE MTG, 3.6-32 ATT PT				4	
- 13	598688	. . . BOARD, 200 CEN WIRE LOW VOLTAGE CONN PART OF BOARD & KEEPER PLATE				1	
- 14	551750	. . . STUD, BOARD MOUNTING				1	
- 15	557575	. . . WASHER, FLAT, 0.390 X 0.2180D X 0.045THK				1	
- 16	557578	. . . SPRING, LATCH CCNNECTOR				1	
- 17	551746	. . . SHAFT, CAM				1	
- 18	1077739	. . . PIN, SPRING, 0.103 X 0.375 LG ATT PT				1	
- 19	251759	. . . RING, RETAINING				2	
- 20	551748	. . . LATCH, LOCK				1	
- 21	598241	. . . STANDOFF				2	
- 22	313289	. . . TERMINAL, LUG, NINS, 20AWG NO.10 MTG HOLE				1	
- 23	324548	. . . NUT, HEX DOUBLE CHAMFER ATT PT				1	
- 24	558240	. . . CLAMP				1	
- 25	598234	. . . SCREW, MACHINE, BH, 10-24 X 1-1/8 LG ATT PT				2	
- 26	598238	. . . COLLIER				1	
- 27	598248	. . . WELL, 90 DEGREEE				1	
- 28	598256	. . . SHELL				1	
- 29	594282	. . . SLEEVE				1	
- 30	249080	. . . SCREW, SOCKET H, 8-32 X 1/4 LG ATT PT				1	
- 31	556940	. . . RELIEF, STAIN				2	
- 32	523176	. . . CCNNECTOR, TWO WAY, WIRE SIZE 24-20				16	
- 33	555725	. . . FERRULE, INNER				7	
- 34	555726	. . . TERMINATOR				7	
- 35	334932	. . . TERMINAL, RING, 18-22 AWG, #10 HOLE, INS				1	
- 36	596255	. . . TERMINAL, SLEE CN, 24-20 AWG				3	
- 37	598041	. . . SOCKET CONTACT				30	
- 38	554282	. . . SLEEVE				1	
- 39	249080	. . . SCREW, SOCKET H, 8-32 X 1/4 LG ATT PT				1	
- 40	556933	. . . PANEL, REAR				1	
- 41	70078	. . . SCREW, SELF-TAP, PAN HD, 6-32 X 1/4 LG ATT PT				4	
- 42	556934	. . . CASE, FIELD TESTER				1	
- 43	58207	. . . SCREW, MACH, UNDRCT EH, 8-32 X 1/4 LG ATT PT				4	
- 44	257189	. . . NUT, HEX, 8-32 ATT PT				4	
- 45	5323472	. . . CABLE ASSEMBLY				1	
- 46	5323473	. . . CABLE ASSEMBLY				1	
- 47	5344923	. . . CABLE ASSEMBLY				1	
- 48	556255	. . . TERMINAL, SLEE CN, 24-20 AWG				20	
- 49	360902	. . . RESISTOR, FXD CCMP, 270 MEG, P/M 5% 1/2W				14	
- 50	334914	. . . RESISTOR, FXD CCMP, 6.2K, 5%, 1/2W				1	
- 51	322347	. . . RESISTOR, FXD CCMP, 560 OHMS, P/M 5% 1/2W				1	
- 52	317016	. . . RESISTOR, FXD CCMP, 820 OHMS, P/M 5% 1/2W				8	
- 53	317018	. . . RESISTOR, FXD, 1.6K, P/M 5% 1/2W				1	
- 54	528486	. . . RESISTOR, 910 OHMS P/M 5% 1/2W				1	
- 55	317008	. . . RESISTOR, FXD, 300 OHMS, 1/2W				1	
- 56	300720	. . . RESISTOR, FXD CCMP, 7.5K P/M 5% 1/2W				1	
- 57	317012	. . . RESISTOR, FXD CCMP, 510 OHMS, P/M 5% 1/2W				1	
- 58	317430	. . . RESISTOR, FXD CCMP, 5.6K, P/M 5% 1/2W				1	
- 59	424133	. . . CAPACITOR, ELECTROLYIC, 100MFD, 15VDC				3	
- 60	492540	. . . CAPACITOR, TANTALUM				1	
- 61	350432	. . . CAPACITOR, FIXED				1	
- 62	350475	. . . CAPACITOR, 1200PF, P/M 10%, 200VDC				1	
- 63	492403	. . . CAPACITOR, 0.0024MFD, P/M 5%, 10/VDC				1	
- 64	350447	. . . CAPACITOR, 560PF, P/M 10%, 20/VDC				1	
- 65	350444	. . . CAPACITOR, 470PF, P/M 10%, 200VDC				1	
- 66	350422	. . . CAPACITOR, 56PF, P/M 10%, 200VDC				1	
- 67	492473	. . . CAPACITOR, ELECT, 33MFD P/M 20% 20V				1	



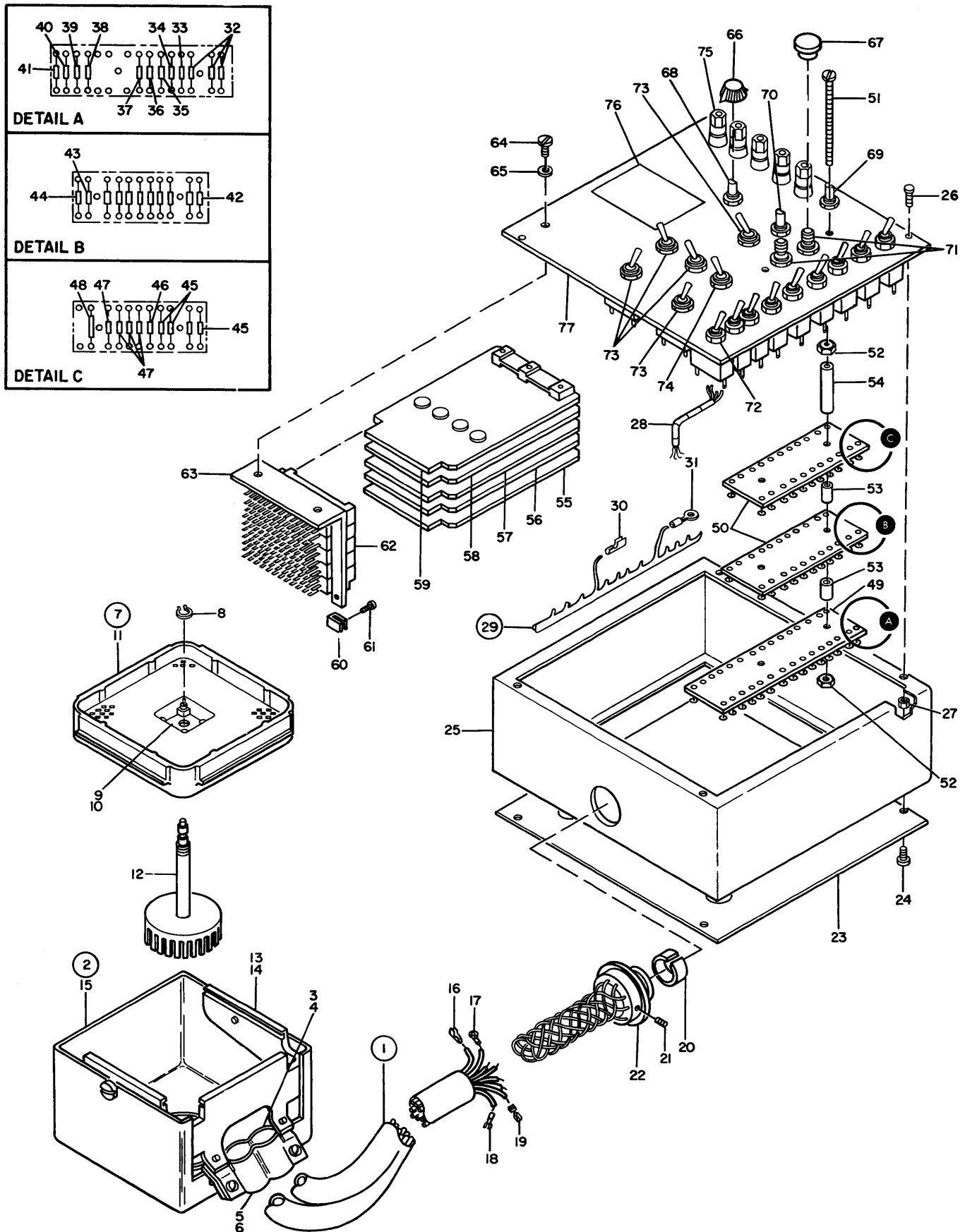

FIGURE 21. 2401 FIELD TESTER ASSEMBLY. SEE LIST 21.

TOOLS AND TEST

LIST AND INDEX NUMBER	PART NUMBER	DESCRIPTION	UNITS PER ASM.	USABLE ON CODE
		2401 FIELD TESTER ASSEMBLY		
21 -	461413	TESTER ASSEMBLY, FIELD, 2401 SEE FIGURE 21 FOR ILLUSTRATION	1	
- 1	5356053	. CABLE ASSEMBLY, MAIN TESTER	1	
- 2	551752	. . . CONNECTOR ASSEMBLY	1	
- 3	551755	. . . CLAMP	1	
- 4	332620	. . . SCREW, MACH, BH 10-32 X 1/2 LG ATT PT	2	
- 5	591754	. . . EFACE	1	
- 6	236849	. . . SCREW, MACHINE, BH, 10-32 X 1/4 LG ATT PT	2	
- 7	551766	. . . BLOCK ASSEMBLY	1	
- 8	234453	. . . RING, RETAINING ATT PT	1	
- 9	551774	. . . BASE, CBM PART OF BLOCK ASM	1	
- 10	25672	. . . SCREW, MACHINE ATT PT	2	
- 11	558688	. . . BOARD, 200 CEN WIRE LOW VOLTAGE CONN PART OF BLOCK ASM	1	
- 12	551769	. . . RETAINER	1	
- 13	591753	. . . FRAME PART OF BLOCK ASM	1	
- 14	236849	. . . SCREW, MACHINE, BH, 10-32 X 1/4 LG ATT PT	2	
- 15	551765	. . . HOOD	1	
- 16	216265	. . . TERMINAL, QUICK DISCON, NCN-INS, 20AWG	9	
- 17	334932	. . . TERMINAL, RING, 18-22 AWG, #10 HOLE, INS	1	
- 18	591649	. . . TERMINATION, COAXIAL-SPLICE	10	
- 19	598041	. . . SOCKET CONTACT	30	
- 20	594282	. SLEEVE	1	
- 21	249080	. SCREW, SOCKET H, 8-32 X 1/4 LG ATT PT	1	
- 22	556940	. RELIEF, STAIN	1	
- 23	556933	. PANEL, REAR	1	
- 24	70078	. SCREW, SELF-TAP, PAN HD, 6-32 X 1/4 LG ATT PT	4	
- 25	5356054	. CASE, FIELD TESTER	1	
- 26	58207	. SCREW, MACH, UNDECT BH, 8-32 X 1/4 LG ATT PT	4	
- 27	257189	. NUT, HEX, 8-32 ATT PT	4	
- 28	5356051	. CABLE ASSEMBLY	1	
- 29	5356052	. CABLE ASSEMBLY	1	
- 30	216265	. . . TERMINAL, QUICK DISCON, NCN-INS, 20AWG	22	
- 31	334932	. . . TERMINAL, RING, 18-22 AWG, #10 HOLE, INS	6	
- 32	424193	. CAPACITOR, ELECTROLYTIC, 100MFD, 15VDC	3	
- 33	492540	. CAPACITOR, TANTALUM	1	
- 34	350432	. CAPACITOR, FIXED	1	
- 35	350475	. CAPACITOR, 1200PF, F/M 10%, 200VDC	1	
- 36	217027	. CAPACITOR, FILM, 0.0036MFD, 5% 100VDC	1	
- 37	317018	. RESISTOR, FXD, 1.6K, P/M 5% 1/2W	1	
- 38	217025	. CAPACITOR, FILM, 0.0043MFD, 5%, 100VDC	1	
- 39	350444	. CAPACITOR, 470PF, F/M 10%, 200VDC	1	
- 40	491226	. CAPACITOR, CERAMIC, 300PF, 5%, 500VDC	1	
- 41	492473	. CAPACITOR, ELECT, 33MFD F/M 20% 20V	1	
- 42	317016	. RESISTOR, FXD CCEP, 820 OHMS, P/M 5% 1/2W	9	
- 43	300720	. RESISTOR, FXD CCME, 7.5K P/M 5% 1/2W	1	
- 44	317018	. RESISTOR, FXD, 1.6K, EM 5% 1/2W	1	
- 45	317004	. RESISTOR, FXD CARBCN, 120 OHMS, 1/2W	4	
- 46	492592	. CAPACITOR, 0.1MFD 100V	1	
- 47	528937	. RESISTOR, FXD, FILM 360 OHMS P/M 5% 1/2W	4	
- 48	369639	. SEMICONDUCTOR DEVICE, DIODE	1	
- 49	5344922	. TERMINAL BOARD	1	
- 50	535058	. TERMINAL BOARD	2	
- 51	556519	. SCREW, MACH, BH, 6-32 X 3 LG ATT PT	2	
- 52	257187	. NUT, PLAIN, HEX 6-32 ATT PT	4	
- 53	5344926	. SPACER	4	
- 54	556935	. SPACER	2	



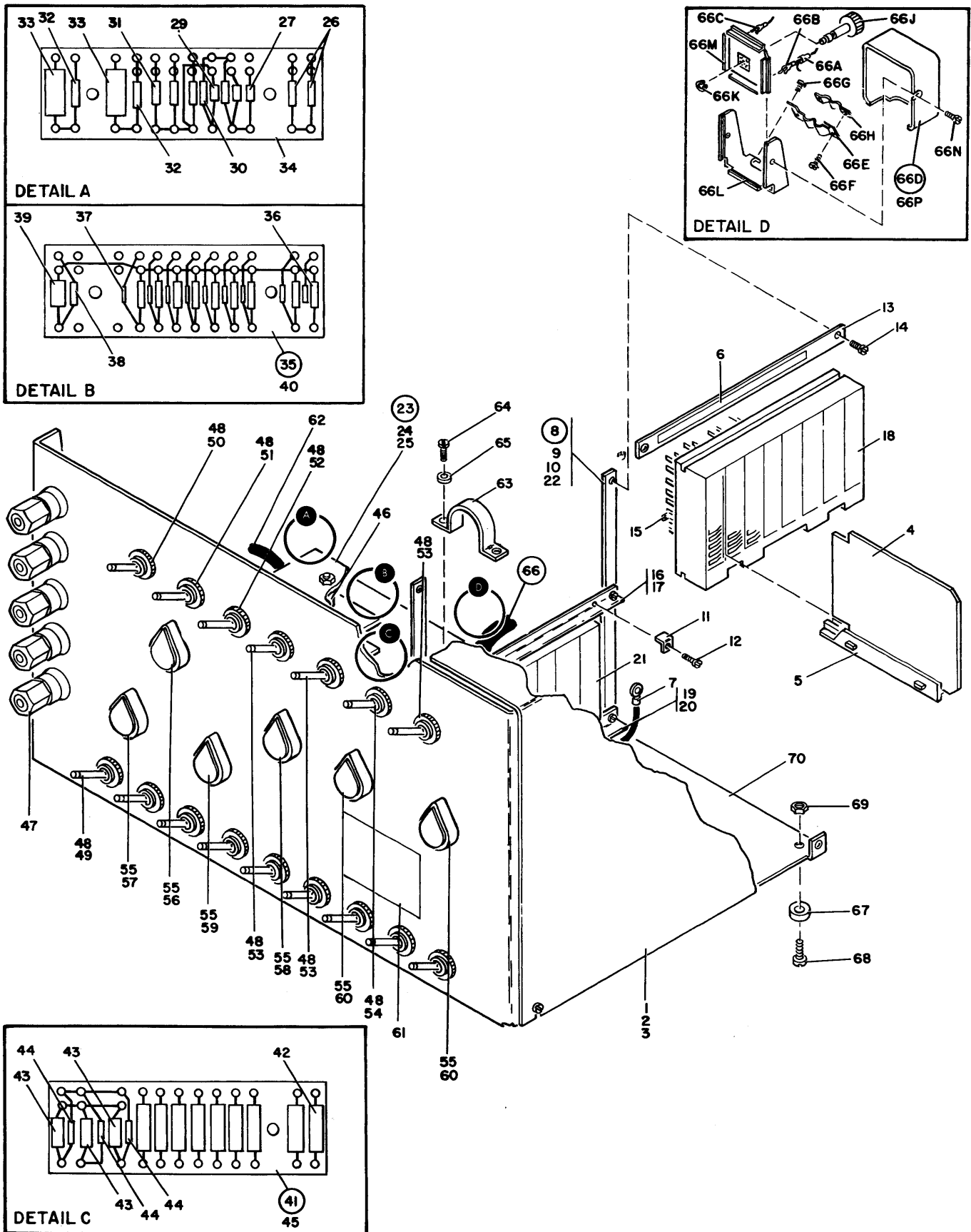

FIGURE 21A. 2400 FIELD TAPE UNIT TESTER ASSEMBLY. SEE LIST 21A.



TOOLS AND TEST

LIST AND INDEX NUMBER	PART NUMBER	DESCRIPTION	UNITS PER ASM.	USABLE ON CODE
		2400 TAPE UNIT TESTER		
21A-	5420330	TESTER ASM SEE FIGURE 21A FOR ILLUSTRATION	1	
- 1	5420332	. COVER	1	
- 2	10170	. SCREW-MACH,BIND HD NC. 6-32 X .250 LG	4	ATT PT
- 3	2502872	. CHANNEL	1	
- 4	375068	. CARD ASM,TSTR-VARIABLE FREQ. OSC. USED IN POSITION A1	1	
- 4	372155	. CARD ASM,TSTR-GATED TRIGGER USED IN POSITION A2	1	
- 4	37C860	. CARD ASM,TSTR-MCID GVER SINGLE SHOT USED IN POSITION A3	1	
- 4	374492	. CARD ASM,TSTR-WRITE BUSS LINE DRIVER USED IN POSITION A4,A5,A6,A7	4	
- 4	372182	. CARD ASM,TSTR-CTEL 3-20MS,120-800MS USED IN POSITION B1	1	
- 4	372080	. CARD ASM,TSTR-CTRI NEI MULTIFLEX REC. USED IN POSITION B2	1	
- 4	37C805	. CARD ASM,TSTR-SDTEL INVERTER,COMPENSATED USED IN POSITION B3	1	
- 4	372079	. CARD ASM,TSTR-CTRI TC SRETL DRIVER USED IN POSITION B4	1	
- 4	37C421	. CARD ASM,TSTR-PEAK DETECTOR INTEGRATOR USED IN POSITION B6	1	
- 4	374900	. CARD ASM,TSTR-SENSE AMP RECT. AND CLIP. USED IN POSITION B7	1	
- 5	216085	. GUIDE-CARD 8 POSITION LONG	2	
- 6	216286	. LABEL-NUMBERING R TO L 1 THRU 28	1	
- 7	5367909	. JUMPER ASSEMBLY-GREEN WIRE	1	
- 8	5420336	. CHASSIS ASSEMBLY-CARD	1	
- 9	10170	. SCREW-MACH,BIND HD NC. 6-32 X .250 LG	2	ATT PT
- 10	56722	. WASHER,LOCK-EXT T .141 ID	1	ATT PT
- 11	528478	. CLIP	2	
- 12	38350	. SCREW,MACH-FIL H 6-32 X 1/4 LG	2	ATT PT
- 13	5420340	. RAIL	1	
- 14	38350	. SCREW,MACH-FIL H 6-32 X 1/4 LG	2	ATT PT
- 15	216215	. BUS-GROUND PLANE	AR	
- 16	5420339	. RAIL	1	
- 17	38350	. SCREW,MACH-FIL H 6-32 X 1/4 LG	2	ATT PT
- 18	5420346	. RECEPTACLE ASSEMBLY,CARD	1	
- 19	5420338	. RAIL	1	
- 20	38350	. SCREW,MACH-FIL H 6-32 X 1/4 LG	2	ATT PT
- 21	5420347	. RECEPTACLE ASSEMBLY,CARD	1	
- 22	5420341	. BRACKET	1	
- 23	5420333	. PCARD ASSEMBLY-TERMINAL	1	
- 24	438572	. SCREW,MACH-UNDRCT BIND HD 6-32 X 2 LG	2	ATT PT
- 25	257187	. NUT-FEX,NO. 6-32	4	ATT PT
- 26	317018	. RESISTOR	2	
- 27	369623	. DIODE	2	
- 29	369118	. DIODE	1	
- 30	528486	. RESISTOR- 910 OHMS P/M 5% 1/2W	1	
- 31	317014	. RESISTOR,FXD,COMP- 680 OHMS P/M 5% 1/2W	3	
- 32	124580	. CAPACITOR-ELECTROLYTIC-0.47 MPD 35VDCW	2	
- 33	438008	. COLLAR	2	
- 34	5356322	. TERMINAL BOARD ASSEMBLY	1	
- 35	5420334	. PCARD ASSEMBLY-TERMINAL	1	
- 36	133840	. CAPACITOR	9	
- 37	479638	. RESISTOR	9	
- 38	369639	. DIODE	1	
- 39	124585	. CAPACITOR-3.30 UF	1	
- 40	5356322	. TERMINAL BOARD ASSEMBLY	1	
- 41	5420335	. PCARD ASSEMBLY-TERMINAL	1	
- 42	479094	. RESISTOR	9	
- 43	502479	. RESISTOR, FXD, COME-360 OHMS P/M 5% 1W	3	
- 44	317004	. RESISTOR ASM	3	
- 45	5356322	. TERMINAL BOARD ASSEMBLY	1	
- 46	325862	. BUSHING,CKT BKR MTG FAC	4	
- 47	320570	. POST,BINDING-BLACK	5	
- 48	216323	. NUT, STEEL, CHROMIUM,	16	
- 49	725347	. SWITCH	9	
- 50	725349	. SWITCH,MOMENTARY-N/C SPDT	1	
- 51	725348	. SWITCH,TOGGLE-DPDT	1	
- 52	737616	. SWITCH, TOGGIE DCUBLE POLE	1	
- 53	734879	. SWITCH, TOGGLE, DPDT,	3	
- 54	737616	. SWITCH, TOGGIE DCUBLE POLE	1	



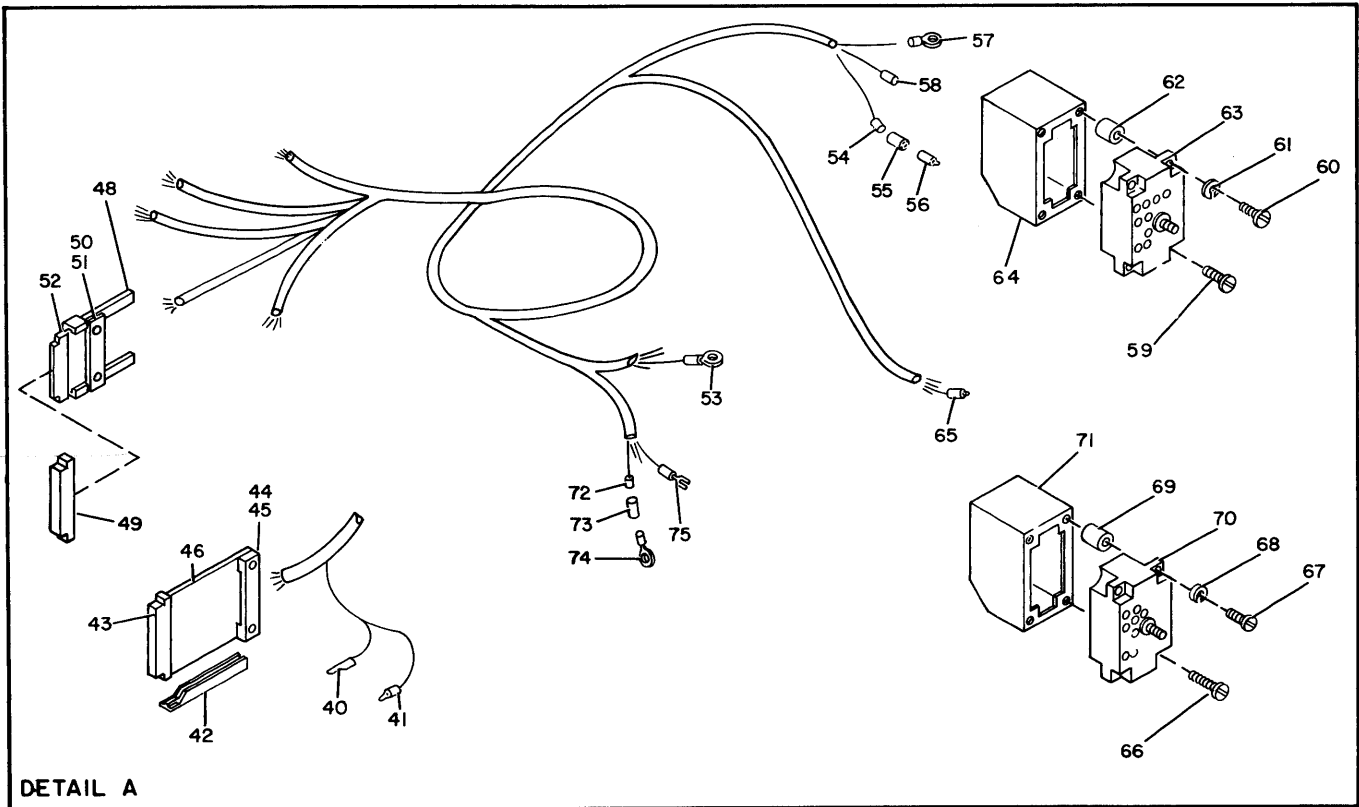
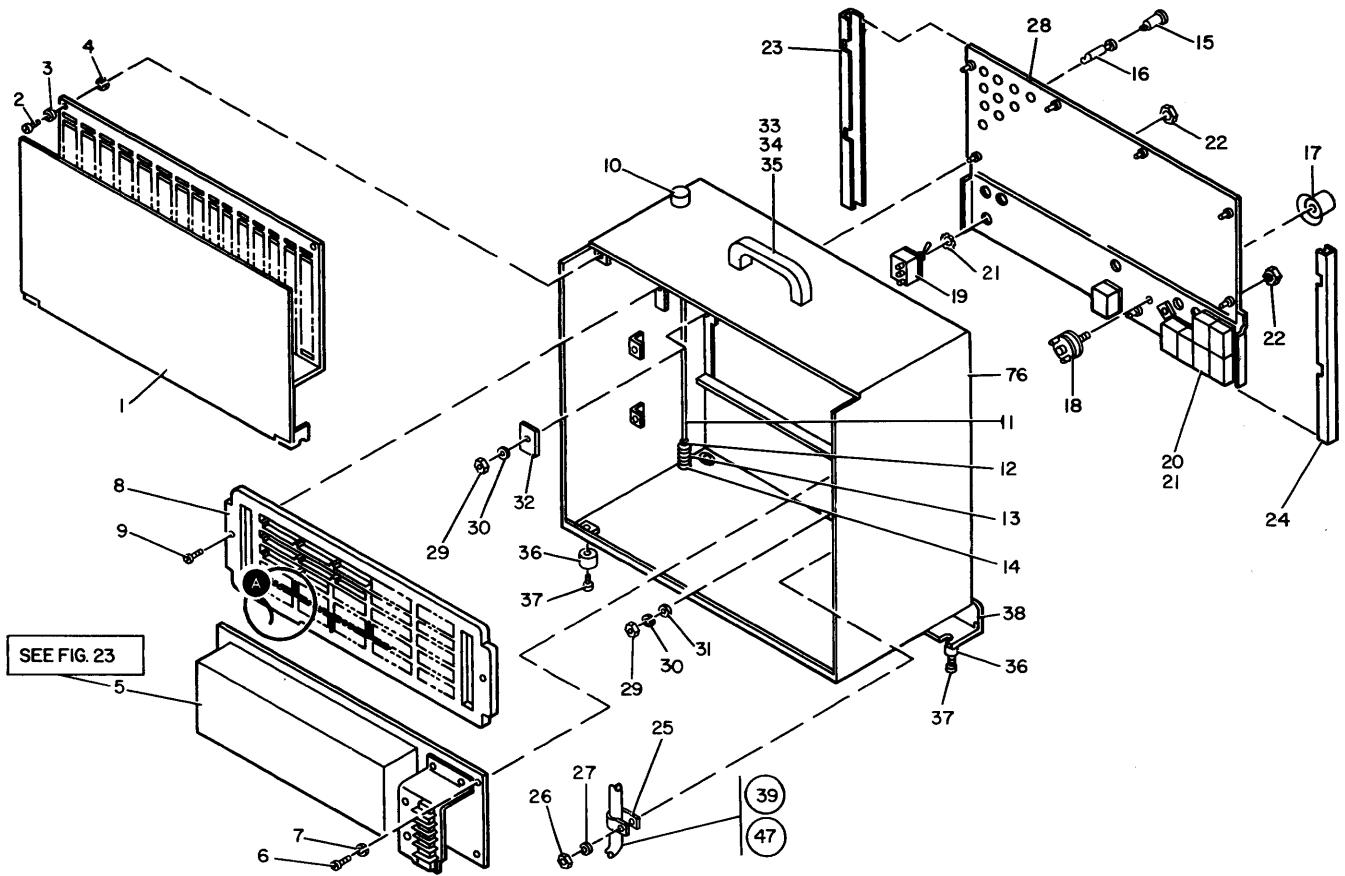

FIGURE 22. I/O TESTER. SEE LIST 22.

TOOLS AND TEST

LIST AND INDEX NUMBER	PART NUMBER	DESCRIPTION	UNITS PER ASM.	USABLE ON CODE
		I/O TESTER		
22 -	45240C	TESTER I/O SEE FIGURE 22 FOR ILLUSTRATION	1	
- 1	740463	. COVER, REAR	1	
- 2	440655	. SCREW, MOUNTING	2	ATT PT
- 3	45651	. WASHER	2	ATT PT
- 4	26464	. CLIP	2	
- 5	5708955	. POWER SUPPLY ASSEMBLY FOR DETAIL BREAKDOWN SEE FIGURE 23	1	
- 6	34512	. SCREW, BH, 8-32 X 0.375 LG	4	ATT PT
- 7	1050873	. WASHER, LCKK, SPLIT RING, 0.168ID, 0.296OD	4	ATT PT
- 8	5811497	. BOARD ASSEMBLY	1	
- 9	236550	. SCREW, MACH, BH, 4-40 X 0.375 LG	2	ATT PT
- 10	821073	. KNOB	1	
- 11	740464	. ROD, HOLDDOWN	1	
- 12	25282	. RING, RETAINING, EXT 0.125ID X 0.015 THK	1	
- 13	444151	. WASHER	1	
- 14	220856	. SPRING, HELICAL, CCMPR, 9 TURNS	1	
- 15	5353889	. INDICATOR ASSEMBLY, CLEAR	90	
- 16	5353887	. HOUSING, IAMP	90	
- 17	480535	. KNOB, CONTROL	1	
- 18	838063	. SWITCH, RECTARY	1	
- 19	738826	. SWITCH, TOGGLE	21	
- 20	738828	. SWITCH, TOGGLE, SPDT, MOMENTARY ACTION	7	
- 21	159373	. WASHER, LCKK, EXT TEETH, 15/32ID X 3/4OD	28	ATT PT
- 22	216323	. NUT, DRESS, KNUHL, 15/32-32 X 41/64 CHR	28	ATT PT
- 23	740456	. GUIDE, RIGHT OVERLAY	1	
- 24	740455	. GUIDE, LEFT OVERLAY	1	
- 25	2102367	. CLAMP, LOOP	1	
- 26	257189	. NUT, HEX, 8-32	1	ATT PT
- 27	22478	. WASHER, FLAT, 0.175ID X 0.375OD 0.03 THK	1	ATT PT
- 28	740453	. PANEL ASSEMBLY	1	
- 29	257187	. NUT, PLAIN, HEX 6-32	7	ATT PT
- 30	6364	. WASHER, LCKK, SPLIT, NO. 6 X 1/4 OD	7	ATT PT
- 31	257986	. WASHER, FLAT, NO. 6 X 0.312 OD	3	ATT PT
- 32	240041	. WASHER, RECTANGULAR	4	
- 33	821067	. HANDLE	1	
- 34	803278	. SCREW, MACH, RH, 10-24 X 5/16 LG	2	ATT PT
- 35	56079	. WASHER, LCKK, EXT TEETH, 0.195ID 0.410OD	2	ATT PT
- 36	731037	. FOOT, CUSHION	4	
- 37	25627	. SCREW, MACH, BH, 8-32 X 0.500 LG	4	ATT PT
- 38	845763	. GUIDE, BOTTOM OVERLAY	1	
- 39	740460	. CABLE ASSEMBLY, IAMP	1	
- 40	5362301	. . CONTACT, LARGE SERPENT, 22-26 AWG	7	
- 41	5404480	. . CONTACT, GREAT SERPENT, 18-20 AWG	5	
- 42	811802	. . GUIDE, CARD	1	
- 43	740459	. . STIFFENER, STRAIN RELIEF	1	
- 44	5352958	. . STRAIN RELIEF	1	
- 45	236550	. . SCREW, MACH, BH, 4-40 X 0.375 LG	2	ATT PT
- 46	5800634	. . CARD ASSEMBLY	1	
- 47	740461	. CABLE ASSEMBLY, INPUT-I/O TESTER	1	
- 48	811802	. . GUIDE, CARD	5	
- 49	740459	. . STIFFENER, STRAIN RELIEF	5	
- 50	5352958	. . STRAIN RELIEF	5	
- 51	236550	. . SCREW, MACH, BH, 4-40 X 0.375 LG	10	ATT PT
- 52	5800634	. . CARD ASSEMBLY	5	
- 53	236916	. . TERMINAL, CONTACT FEMALE 24-22 AWG	12	
- 54	595726	. . TERMINATOR	1	
- 55	595725	. . FERRULE, INNER	1	
- 56	2122261	. . SOCKET, CONTACT, 18-16 AWG	1	
- 57	2122259	. . TERMINAL, SOCKET CONTACT, 22-20 AWG	3	
- 58	2127890	. . SOCKET, CONTACT, AWG 26-24	AR	
- 59	740576	. . SCREW, HEX H, SOCKET, 6-32 X 0.625LG	2	
- 60	322550	. . SCREW, MACH, BH, 6-32 X 1/2 LG	2	
- 61	6364	. . WASHER, LCKK, SPLIT, NO. 6 X 1/4 OD	2	
- 62	24588	. . CCLLAR	4	
- 63	741136	. . CONNECTOR	1	
- 64	741137	. . SHIELD	1	
- 65	2127890	. . SOCKET, CONTACT, AWG 26-24	6	
- 66	740576	. . SCREW, HEX H, SOCKET, 6-32 X 0.625LG	2	
- 67	322550	. . SCREW, MACH, BH, 6-32 X 1/2 LG	2	
- 68	6364	. . WASHER, LCKK, SPLIT, NO. 6 X 1/4 OD	2	
- 69	24588	. . CCLLAR	4	
- 70	741136	. . CONNECTOR	1	
- 71	741137	. . SHIELD	1	
- 72	595726	. . TERMINATOR	1	
- 73	595725	. . FERRULE, INNER	1	
- 74	334932	. . TERMINAL, RING, 18-22 AWG, #10 HOLE, INS	1	
- 75	186967	. . TERMINAL, SPADE, 20-24 AWG, #6 HOLE, NINS	7	
- 76	740452	. . BOX, I/O TESTER	1	

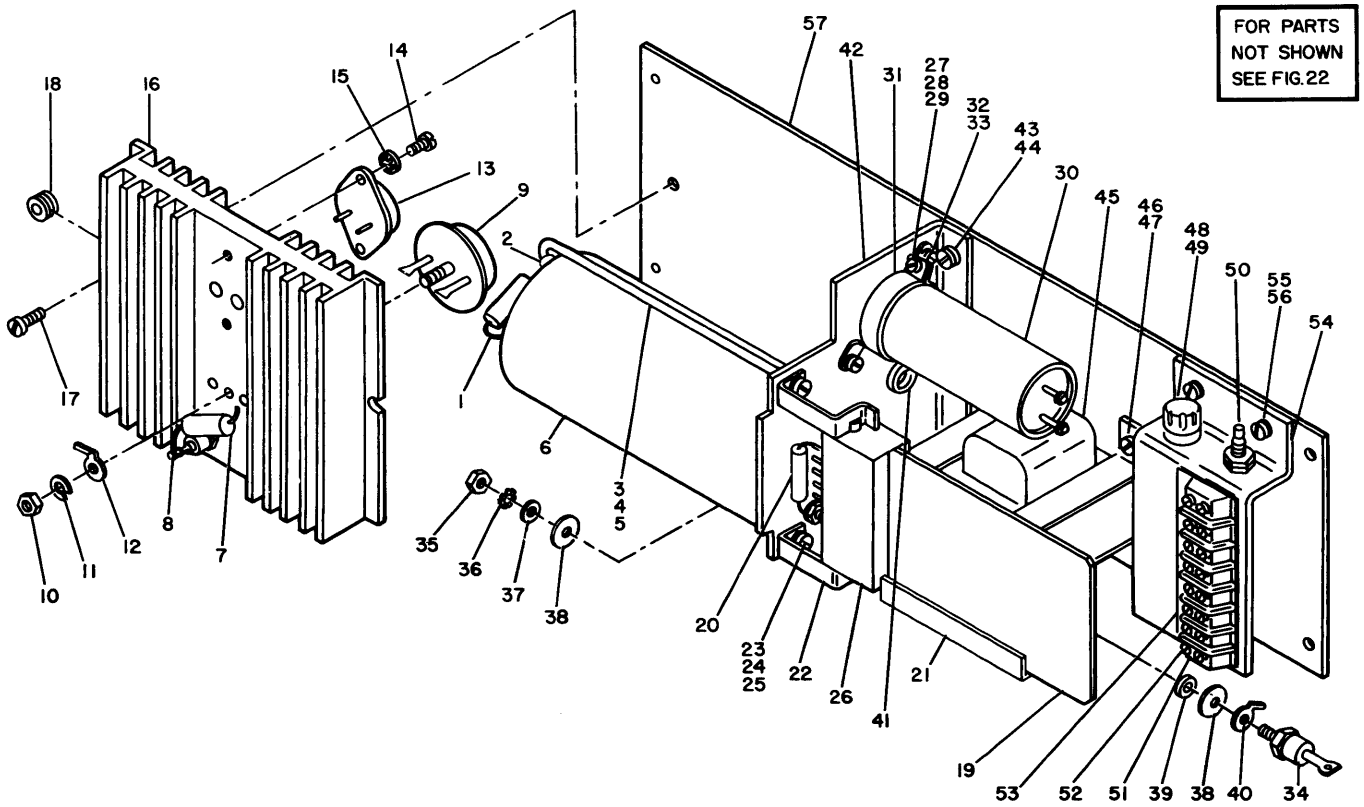

FIGURE 23. I/O TESTER POWER SUPPLY. SEE LIST 23.

TOOLS AND TEST

LIST AND INDEX NUMBER	PART NUMBER	DESCRIPTION	UNITS PER ASM.	USABLE ON CODE
		I/O TESTER POWER SUPPLY		
23 -	57C8955	POWER SUPPLY, I/O TESTER SEE LIST 22-5 FOR NEXT HIGHER ASSEMBLY AND FIGURE 23 FOR ILLUSTRATION	REF	
- 1	57C8949	. RESISTOR ASSEMBLY	1	
- 2	473412	. INSULATOR, CAPACITOR CLAMP	2	
- 3	473422	. CLAMP, CAPACITOR	2	
- 4	38051	. NUT, PLAIN, HEX, 6-32 X 1/4 FL W	2	ATT PT
- 5	56722	. WASHER, LCCK, EXTERNAL TCCTH NO. 6	2	ATT PT
- 6	478953	. CAPACITOR, ELECTROLYTIC, 15KMF	1	
- 7	207324	. RESISTOR, FXD, WW, 0.1 CHM, P/M 5% 5W	1	
- 8	323925	. TERMINAL	1	
- 9	369214	. TRANSISTOR, TYPE 108	1	
- 10	11598	. NUT, PLAIN, HEX, 10-32 X 3/8 FL W	1	ATT PT
- 11	56C79	. WASHER, LCCK, EXT TEETH, 0.195ID 0.410OD	1	ATT PT
- 12	316996	. TERMINAL, LUG, NINS, 9AWG NO. 8 MTG HOLE	1	
- 13	368616	. TRANSISTOR, TYPE 119	1	
- 14	322550	. SCREW, MACH, BH, 6-32 X 1/2 LG	2	ATT PT
- 15	62031	. WASHER, LCCK, INT TEETH, NO.6 X 0.295 OD	2	ATT PT
- 16	57C8952	. HEATSINK	1	
- 17	337	. SCREW, MACH, FII H, 8-32 X 3/8 LG	2	ATT PT
- 18	327548	. INSULATOR, FEAT SIK MOUNTING	2	ATT PT
- 19	374818	. CARD ASSEMBLY	1	
- 20	5266079	. CAPACITOR ASSEMBLY	1	
- 21	216206	. GUIDE, SINGLE CARD LONG	1	
- 22	57C8957	. BRACKET, CARD SOCKET	2	
- 23	10170	. SCREW, MACH, BH, 6-32 X 1/4 LG	2	ATT PT
- 24	6364	. WASHER, LCCK, SPLIT, NO. 6 X 1/4 OD	2	ATT PT
- 25	257586	. WASHER	2	ATT PT
- 26	216076	. TERMINAL BLOCK AND CONTACT ASSEMBLY	1	
- 27	510379	. SCREW	1	
- 28	56722	. WASHER, LCCK, EXTERNAL TCCTH NO. 6	1	ATT PT
- 29	38051	. NUT, PLAIN, HEX, 6-32 X 1/4 FL W	1	ATT PT
- 30	5261089	. CAPACITOR, ELECT, CAN TYPE	1	
- 31	301768	. BRACKET, MOUNTING	2	
- 32	38235	. SCREW, MACH, BH, 6-32 X 0.312 LG	2	ATT PT
- 33	56722	. WASHER, LCCK, EXTERNAL TCCTH NO. 6	2	ATT PT
- 34	558479	. SEMICONDUCTOR DEVICE, DIODE, 150V 10A	1	
- 35	11598	. NUT, PLAIN, HEX, 10-32 X 3/8 FL W	1	ATT PT
- 36	56C79	. WASHER, LCCK, EXT TEETH, 0.195ID 0.410OD	1	ATT PT
- 37	45690	. WASHER, FL, NO.10 X 7/16 OD X 1/32 THK	1	ATT PT
- 38	419130	. WASHER, MICA, 0.195ID, 5/8OD X 0.002THK	2	ATT PT
- 39	473582	. INSULATOR	1	ATT PT
- 40	316996	. TERMINAL, LUG, NINS, 9AWG NO. 8 MTG HOLE	1	
- 41	227379	. GROMMET, RUBBER, PCE 5/8 HOLE X 1/8 DIA	1	
- 42	57C8953	. BRACKET, POWER SUPPLY	1	
- 43	186759	. SCREW, MACH, BH, 8-32 X 5/16 LG	2	ATT PT
- 44	55901	. WASHER, LCCK, EXT TEETH, NO.8 X 0.381OD	2	ATT PT
- 45	57C8951	. TRANSFORMER, PCWER	1	
- 46	58207	. SCREW, MACH, UNDERCT BH, 8-32 X 1/4 LG	4	ATT PT
- 47	55901	. WASHER, LCCK, EXT TEETH, NO.8 X 0.381OD	5	ATT PT
- 48	111256	. FUSE, 1.5 AMP	1	
- 49	1104137	. FUSEHOLDER	1	
- 50	441181	. POTENTIOMETER	1	
- 51	317232	. TERMINAL BOARD, 6 IBL SCREW TERMINALS	1	
- 52	35739	. SCREW, MACH, BH, 6-32 X 15/16 LG	4	ATT PT
- 53	589715	. STRIP, MARKER	1	
- 54	57C8954	. BRACKET, TERMINAL BOARD	1	
- 55	186759	. SCREW, MACH, BH, 8-32 X 5/16 LG	2	ATT PT
- 56	55901	. WASHER, LCCK, EXT TEETH, NO.8 X 0.381OD	2	ATT PT
- 57	57C8956	. CHASSIS, I/O TESTER	1	

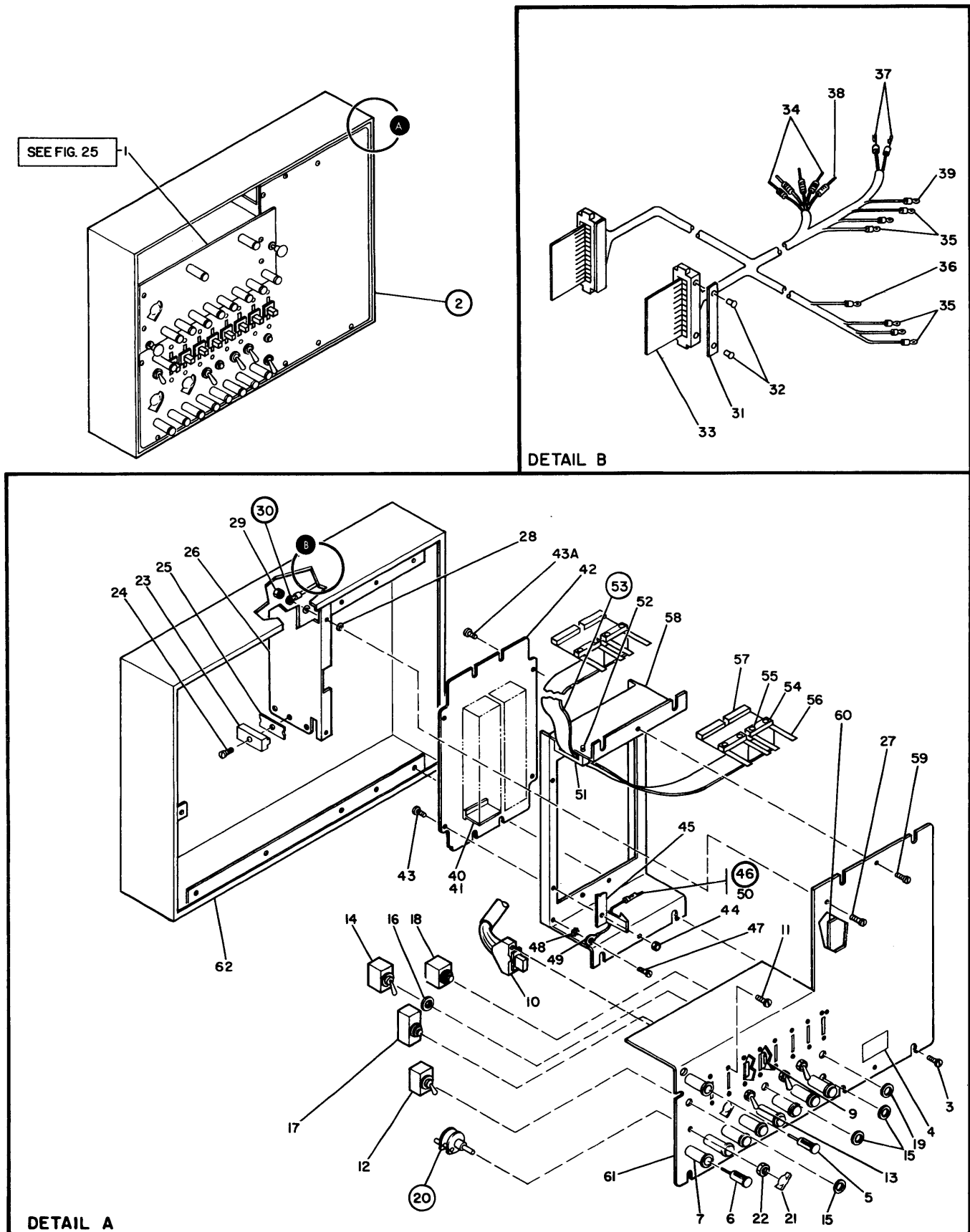

FIGURE 24. C. E. BOX ASSEMBLY. SEE LIST 24.

TCCLS AND TEST

LIST AND INDEX NUMBER	PART NUMBER	DESCRIPTION	UNITS PER ASM.	USABLE ON CODE
		C. E. BOX ASSEMBLY		
24 -	2200012	BOX ASSEMBLY, C.E. 2311/2314	1	
- 1	2200014	SEE FIGURE 24 FOR ILLUSTRATION BOX ASSEMBLY, INDICATOR	1	
- 2	2200013	SEE LIST 25 FOR DETAIL BREAKDOWN CE BOX ASSEMBLY, CCNTFCL UNIT	1	
- 3	2181005	SCREW, SELF TAPPING, 6-32 X 0.375 LG.	7	
- 4	2181119	SERIAL TAG, FILE TEST BCX	1	
- 5	5353883	INDICATOR ASSEMBLY, AMBER-3 VOLT	1	
- 6	5353889	INDICATOR ASSEMBLY, CLEAR	8	
- 7	5353887	HOUSING, LAMP	9	
- 9	369218	SEMICONDUCTOR DEVICE, DIODE	5	
- 10	555049	SWITCH, LEVER, SHORTING, 2POLE, 2POS	8	
- 11	1C17C	SCREW, MACH, BH, 6-32 X 1/4 LG	16	ATT PT
- 12	734878	SWITCH, TOGGLE, SPDT, CENTER OFF	1	
- 13	765748	SWITCH, TOGGLE	1	
- 14	738826	SWITCH, TOGGLE	3	
- 15	216323	NUT, DRESS, KNURL, 15/32-32 X 41/64 CHR	5	ATT PT
- 16	159373	WASHER, LOCK, EXT TEETH, 15/32ID X 3/4OD	5	ATT PT
- 17	117184	SWITCH, PUSH, NC, 125VAC 1A	1	
- 18	358844	SWITCH, PUSH	1	
- 19	216323	NUT, DRESS, KNURL, 15/32-32 X 41/64 CHR	2	ATT PT
- 20	354167	SWITCH, RCTARY, 1 DECK, 1 POLE, 7 POS	2	
- 21	30C793	KNOB, SWITCH	2	
- 22	220032	NUT, PLAIN, HEX, 3/8-32 X 1/2 PL W	2	
- 23	302090	CONNECTOR, RECF, ELEC, 24 FEMALE CONT	1	
- 24	2191846	SCREW, EDGE CONNECTOR MOUNTING	1	ATT PT
- 25	302131	INSULATOR, TERMINAL BLOCK	1	
- 26	2181106	PARTITION, CABIE	1	
- 27	2181005	SCREW, SELF TAPPING, 6-32 X 0.375 LG.	2	ATT PT
- 28	56722	WASHER, LOCK, EXTERNAL TOOTH NO. 6	2	ATT PT
- 29	257187	NUT, PLAIN, HEX 6-32	1	ATT PT
- 30	2181112	CABLE ASSEMBLY, CE TEST BOX	1	
- 31	5352960	STRAIN RELIEF, COAX TWO-HI APPLICATION	2	
- 32	595720	RIVET, ROLLED FLANGE	4	
- 33	58C0610	CARD ASSEMBLY, TERMINATOR	2	
- 34	187243	TERMINAL, SMALL TAPER	4	
- 35	236916	TERMINAL, CONTACT FEMALE 24-22 AWG	4	
- 36	334921	TERMINAL, RING, 18-22 AWG, #6 HOLE, INS	1	
- 37	5362301	CONTACT, LARGE SERPENT, 22-26 AWG	18	
- 38	360433	TERMINAL, FIUG, 16-18 AWG	1	
- 39	236915	TERMINAL, SIDE-CN, 20-18 AWG	1	
- 40	811363	EXTENDER, CARD, 6 PAC	10	
- 41	58C0000	CARD ASSEMBLY	4	
- 41	58C0099	CARD ASSEMBLY, SIT	2	
- 41	58C0069	CARD ASSEMBLY, SIT	2	
- 41	5800236	CARD ASSEMBLY, SIT	2	
- 41	5800247	CARD ASSEMBLY, SIT	2	
- 41	58C0346	CARD ASSEMBLY, SIT	1	
- 41	58C0347	CARD ASSEMBLY, SIT	1	
- 41	58C0509	CARD ASSEMBLY, 6-PAC	1	
- 41	58C0703	CARD ASSEMBLY, SIT	2	
- 41	58C0725	CARD ASSEMBLY, SIT	1	
- 41	58C4018	CARD ASSEMBLY, SIT	1	
- 41	5804663	CARD ASSEMBLY, SIT	1	
- 42	2181110	BOARD ASSEMBLY	1	
- 43	731627	SCREW, MACH, PAN H, 6-32 X 0.75 LG	2	ATT PT
- 43	811426	SCREW, MACH, PAN H, 6-32 X 3/8 LG	2	ATT PT
- 44	344015	NUT, SELF LKG, HEX, 6-32 X 5/16 PL W	2	ATT PT
- 45	2180972	CLAMP, PADDLE CONNECTOR, SLT	1	
- 46	2181117	JUMPER ASSEMBLY, 3-1/4 INCHES LONG	1	
- 47	731626	SCREW	1	ATT PT
- 48	56722	WASHER, LOCK, EXTERNAL TOOTH NO. 6	1	ATT PT
- 49	253453	TERMINAL, RING, 22-26 AWG, #6 HOLE, INS	1	
- 50	813810	TERMINAL, QUICK DISCONNECT	1	
- 51	2180973	CLAMP, SLT CARD	1	
- 52	57C0484	SCREW, SELF TAPPING, 4-40 X 0.375 LG	2	ATT PT
- 53	2181113	CABLE ASSEMBLY, CE BCX TO FILE	1	
- 54	5352960	STRAIN RELIEF, COAX TWO-HI APPLICATION	AR	
- 54	218C573	CLAMP, SIT CARD	AR	
- 55	595720	RIVET, ROLLED FLANGE	8	ATT PT
- 56	811804	GUIDE, CARD	2	
- 57	5819436	CARD, CONNECTOR	2	
- 58	2181101	BRACKET, BOARD MOUNTING	1	
- 59	2181005	SCREW, SELF TAPPING, 6-32 X 0.375 LG.	2	ATT PT
- 60	2181133	FOAM, 9 X 6, 0.13 THICK	1	
- 61	2181102	PANEL, CE BOX	1	
- 62	2181104	CASE ASSEMBLY, CE BOX	1	



FOR PARTS  
NOT SHOWN  
SEE FIG. 24

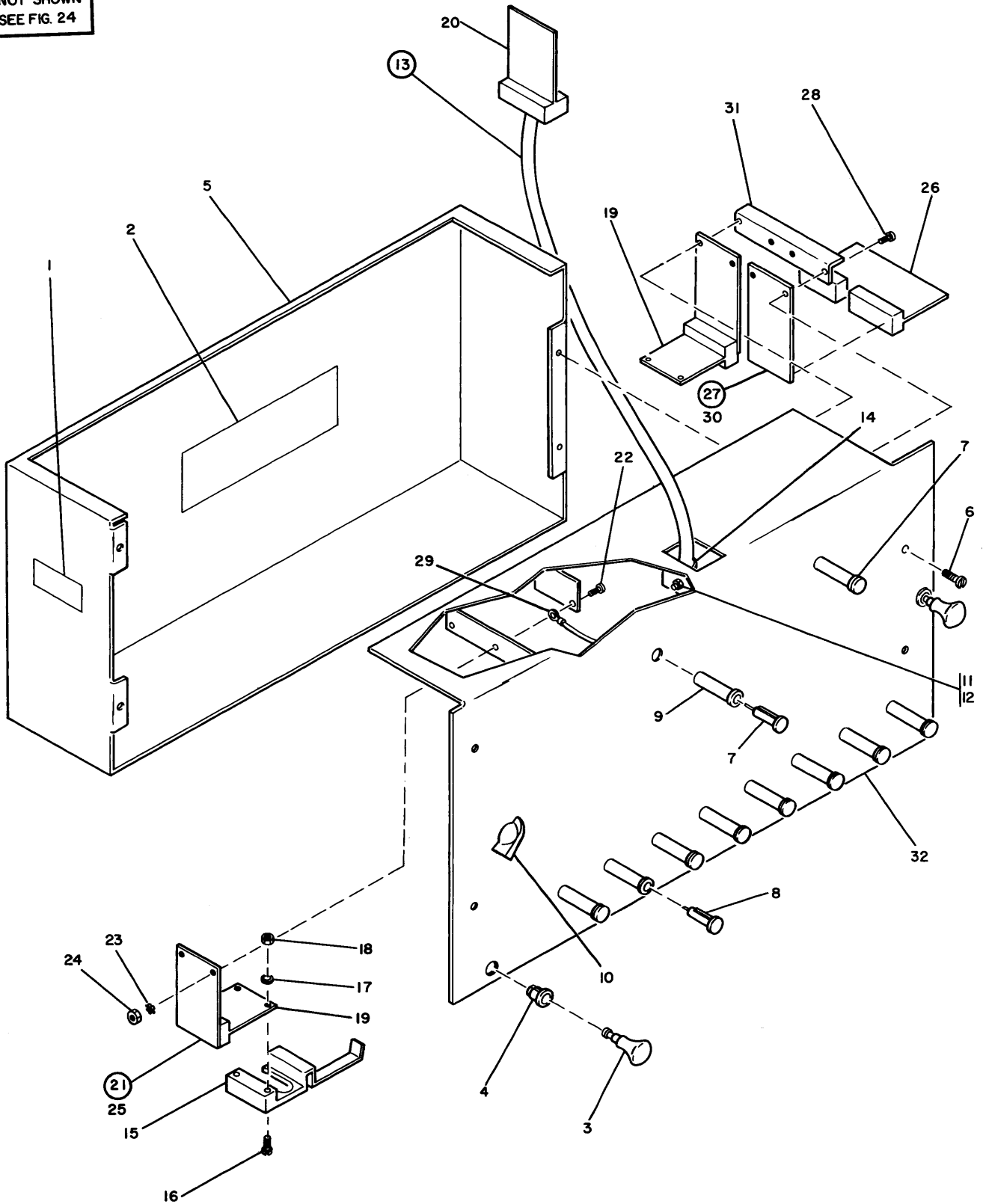

FIGURE 25. INDICATOR BOX ASSEMBLY. SEE LIST 25.



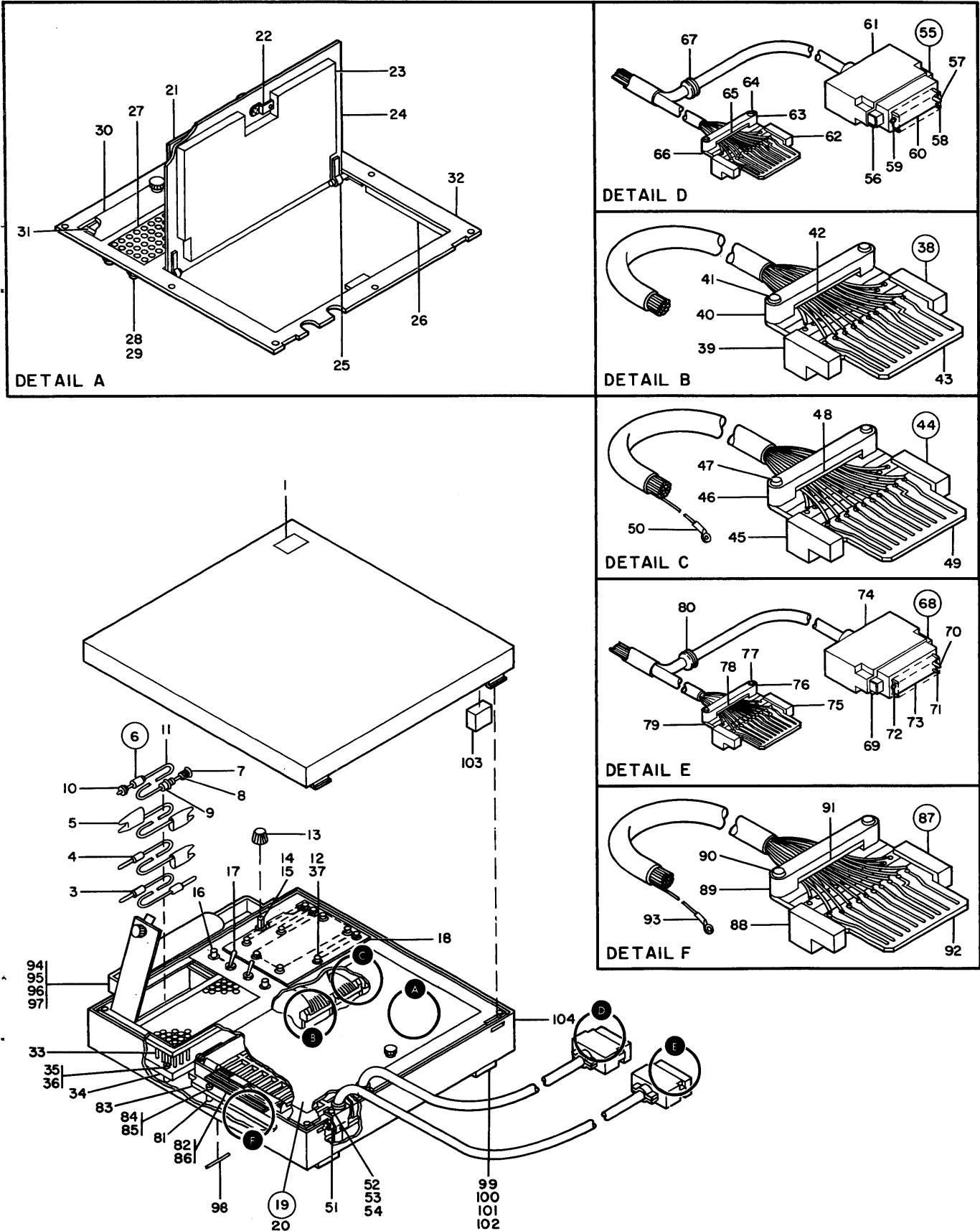

FIGURE 26. C. E. BOX ASSEMBLY. SEE LIST 26.

TOOLS AND TEST

LIST AND INDEX NUMBER	PART NUMBER	DESCRIPTION	UNITS PER ASM.	USABLE ON CODE
		C. E. BOX ASSEMBLY		
26 -	5052684	CE BOX ASSEMBLY 1070 SEE FIGURE 26 FOR ILLUSTRATION	1	
- 1	438814	. PLATE, DESIGNATION	1	
- 3	186586	. WIRE ASSEMBLY, 6 INCH	50	
- 4	2197865	. WIRE ASSEMBLY	6	
- 5	2197864	. LEAD ASSEMBLY, ELECTRICAL, 15 IN. LG	2	
- 6	2197918	. SWITCH ASSEMBLY	1	
- 7	734960	. . BUTTON	1	
- 8	734963	. . SWITCH	1	
- 9	734961	. . HCUSING	1	
- 10	351122	. . CONNECTOR, PLUG, ELEC, 2 MALE CONTACTS	1	
- 11	176106	. . CABLE	1	
- 12	550511	. LAMP, INCANDESCENT, 10V 14 WA	54	
- 13	3C0793	. KNOB, SWITCH	1	
- 14	741862	. SWITCH	1	
- 15	220032	. NUT, PLAIN, HEX, 3/8-32 X 1/2 FL W	1	ATT PT
- 16	365047	. SWITCH, PUSH, SEDT 125VAC 1 AMP	2	
- 17	368164	. SWITCH, TOGGLE, DPDT	2	
- 18	2198862	. PANEL, MASK	1	
- 19	5052667	. PANEL ASSEMBLY, FRCNT	1	
- 20	67873	. SCREW, SELF-TAP, PAN HD, 4-40 X 3/16LG	8	ATT PT
- 21	2197917	. . LABEL, PANEL	1	
- 22	2198227	. . DOOR LATCH, KNCB AND PAWL	2	
- 23	5052994	. . FCAM, CARD STOP	1	
- 24	5052995	. . DCCR, PANEL	1	
- 25	5052996	. . SHAFT, HINGE	2	ATT PT
- 26	5052670	. . FOAM, CARD STOP	1	
- 27	5052681	. . CONTROL PANEL	1	
- 28	257187	. . NUT, PLAIN, HEX 6-32	4	ATT PT
- 29	56722	. . WASHER, LOCK, EXTERNAL TOOTH NO. 6	4	ATT PT
- 30	5052674	. . PANEL, APERTURE	1	
- 31	5052676	. . SHAFT, HINGE	1	ATT PT
- 32	5052668	. . PANEL ASSEMBLY, FRCNT	1	
- 33	474180	. CONTACT ASSEMBLY	180	
- 34	5052981	. BOARD, CBM PROGRAM	1	
- 35	36354	. SCREW, MACH, FTH H, 6-32 X 1/2 LG	4	ATT PT
- 36	62031	. WASHER, LOCK, INT TEETH, NO. 6 X 0.295 OD	4	ATT PT
- 37	368168	. CLIP, SPEED	54	
- 38	5052547	. CABLE ASSEMBLY, CE BOX	1	
- 39	811802	. . GUIDE, CARD	1	
- 40	5353922	. . CLAMP, STRAIN RELIEF	1	
- 41	555720	. . RIVET, ROLLED FLANGE	2	ATT PT
- 42	2197989	. . SPACER, STRAIN RELIEF	1	
- 43	5800610	. . CARD ASSEMBLY, TERMINATOR	1	
- 44	5052723	. CABLE ASSEMBLY, CE BOX	1	
- 45	811802	. . GUIDE, CARD	3	
- 46	5353922	. . CLAMP, STRAIN RELIEF	3	
- 47	555720	. . RIVET, ROLLED FLANGE	6	ATT PT
- 48	2197989	. . SPACER, STRAIN RELIEF	3	
- 49	5800610	. . CARD ASSEMBLY, TERMINATOR	3	
- 50	368169	. . TERMINAL, SIDE CN-20 AWG	108	
- 51	2122839	. CLAMP, STRAIN RELIEF	2	
- 52	38433	. SCREW, MACH, FH, 4-40 X 1/4 LG	4	ATT PT
- 53	150208	. WASHER, LOCK, INT TEETH, NO. 4 X 17/64OD	4	ATT PT
- 54	37913	. NUT, HEX, 4-40	4	ATT PT
- 55	5052546	. CABLE ASSEMBLY	1	
- 56	2127988	. . SPRING, LOCKING, 30 AND 50 POS CONNECTOR	2	
- 57	2122202	. . SOCKET, GUIDE	1	
- 58	2122258	. . PIN, CONTACT, MALE, 20/22 AWG	42	
- 59	2122203	. . PIN, GUIDE, BRASS, SUPPLIED W/HARDWARE	1	
- 60	2122471	. . CONNECTOR, PLUG, 50 MALE CONTACTS	1	
- 61	2127894	. . HOOD-50 POS	1	
- 62	811802	. . GUIDE, CARD	1	
- 63	5353922	. . CLAMP, STRAIN RELIEF	1	
- 64	555720	. . RIVET, ROLLED FLANGE	2	ATT PT
- 65	2197989	. . SPACER, STRAIN RELIEF	1	
- 66	5800610	. . CARD ASSEMBLY, TERMINATOR	1	
- 67	123072	. . GROMMET	1	

TCOLS AND TEST

LIST AND INDEX NUMBER	PART NUMBER	DESCRIPTION	UNITS PER ASM.	USABLE ON CODE
26 - 68	5052685	. CABLE ASSEMBLY, CE BOX	1	
- 69	2127988	. . SPRING, LOCKING, 30 AND 50 POS CONNECTOR	2	
- 70	2122202	. . SOCKET, GUIDE	1	
- 71	2122256	. . PIN, CONTACT, MALE, 20/22 AWG	34	
- 72	2122203	. . PIN, GUIDE, BRASS, SUPPLIED W/HARDWARE	1	
- 73	2122257	. . CCNECTOR, PLUG, 34 MALE CONTACTS	1	
- 74	2127864	. . HOOD, 34 POSITION	1	
- 75	811802	. . GUIDE, CARD	1	
- 76	5353922	. . CLAMP, STRAIN RELIEF	1	
- 77	55572C	. . RIVET, RILED FLANGE ATT PT	2	
- 78	2157989	. . SPACER, STRAIN RELIEF	1	
- 79	58C061C	. . CARD ASSEMBLY, TERMINATOR	1	
- 80	123072	. . GROMMET	1	
- 81	5052656	. . SPACER, 6-32 INT THD 0.652 LG	12	
- 82	811802	. . GUIDE, CARD	39	
- 83	505257E	. . BOARD ASSEMBLY, PERSONALITY	1	
- 84	38352	. . SCREW, MACH, FII H, 6-32 X 3/8 LG ATT PT	8	
- 85	62031	. . WASHER, LCCK, INT TEETH, NO.6 X 0.295 OD ATT PT	8	
- 86	813621	. . POST, GUIDE	13	
- 87	2197811	. . CABLE ASSEMBLY, CE BOX	1	
- 87	2197812	. . CABLE ASSEMBLY, CE BOX	1	
- 87	2197813	. . CABLE ASSEMBLY, CE BOX	1	
- 87	2197814	. . CABLE ASSEMBLY, CE BOX	1	
- 87	2157815	. . CABLE ASSEMBLY, CE BOX	1	
- 88	811802	. . GUIDE, CARD	1	
- 89	5353922	. . CIAMP, STRAIN RELIEF	1	
- 90	55572C	. . RIVET, RILED FLANGE ATT PT	2	
- 91	2157989	. . SPACER, STRAIN RELIEF	1	
- 92	58C061C	. . CARD ASSEMBLY, TERMINATOR	1	
- 93	179CC7	. . TERMINAI, QUICK DISCCNECT, NONINS 20AWG	AR	
- 94	505266C	. . HANDLE	1	
- 95	32617	. . SCREW, MACH, BH, 10-32 X 0.438 LG ATT PT	2	
- 96	56C79	. . WASHER, LCCK, EXT TEETH, 0.195ID 0.410OD ATT PT	2	
- 97	1159E	. . NUT, FLAIN, HEX, 10-32 X 3/8 FL W ATT PT	2	
- 98	2122337	. . SEAL	2	
- 99	1132694	. . FOOT, RUBBER	2	
-100	845	. . SCREW, MACH, FII H, 8-32 X 1/2 LG ATT PT	4	
-101	55901	. . WASEER, LCCK, EXT TEETH, NO.8 X 0.381OD ATT PT	4	
-102	257189	. . NUT, HEX, 8-32 ATT PT	4	
-103	505266E	. . COVER, BUMPER	4	
-104	5052656	. . CABINET	1	





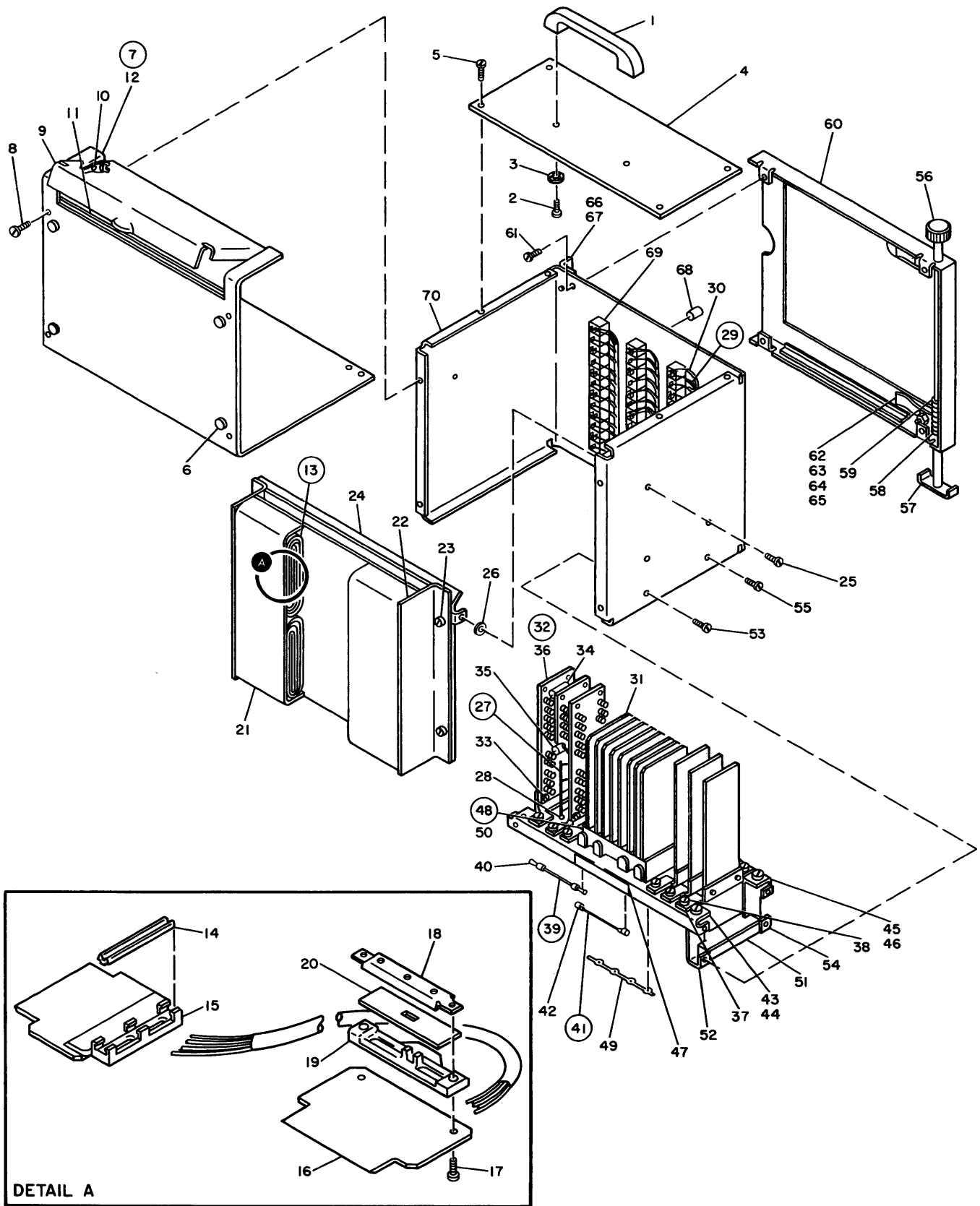

FIGURE 28. C. E. FOX ASSEMBLY. SEE LIST 28.



TOOLS AND TEST

LIST AND INDEX NUMBER	PART NUMBER	DESCRIPTION				UNITS PER ASM.	USABLE ON CODE
		1	2	3	4		
		C. E. BOX ASSEMBLY					
28 -	82105C	BOX ASSEMBLY, C.E. 1440 SEE FIGURE 28 FOR ILLUSTRATION				1	
- 1	821067	HANDLE				1	
- 2	803278	. SCREW, MACH, RH, 10-24 X 5/16 LG				ATT PT	2
- 3	56121	. WASHER, LCCK, INT TEETH, NO.10 X 0.3810D				ATT PT	2
- 4	821058	. COVER, TOP					1
- 5	731626	. SCREW				ATT PT	4
- 6	36C193	. BUMPER					8
- 7	821052	. COVER ASSEMBLY, CE BOX					1
- 8	731626	. SCREW				ATT PT	10
- 9	821054	. . COVER, HINGE					1
- 10	1656C5	. RIVET				ATT PT	2
- 11	821056	. . STOP					1
- 12	821053	. . COVER, BACK					1
- 13	821099	. CABLE ASSEMBLY					1
- 14	2163C0	. . PLUG, STRAIN RELIEF					1
- 15	2163C4	. . STRAIN RELIEF					1
- 16	396071	. . CARD					1
- 17	236550	. . SCREW, MACH, RH, 4-40 X 0.375 LG				ATT PT	3
- 18	2162C8	. . CLAMP, CABLE CONNECTOR					1
- 19	2162C9	. . SUPPORT, CABLE CONNECTOR CARD					1
- 20	216210	. . SPACER, CABLE CONNECTOR					1
- 21	821C69	. HOLDER, CABLE					1
- 22	821060	. BRACKET, DIVIDER					2
- 23	731626	. SCREW				ATT PT	4
- 24	821059	. DIVIDER					1
- 25	724483	. SCREW, MACH, PAN H, 6-32 X C.380 LG				ATT PT	1
- 26	6444	. WASHER, FLAT, NC. 8 X 3/8 OI X 3/32 THK				ATT PT	1
- 27	822949	. CABLE ASSEMBLY, RB1, 2, 3 TC CS					1
- 27	726588	. CABLE ASSEMBLY, CE AID BOX					1
- 28	216265	. . TERMINAL, QUICK DISCON, NCN-INS, 20AWG USED CN ASM 822949					29
- 28	596255	. . TERMINAL, SLIP ON, 24-20 AWG USED CN ASM 726588					29
- 29	743046	. CABLE ASSEMBLY, RB2 TC LAMPS					1
- 29	743047	. CABLE ASSEMBLY, RB3 TC LAMPS					1
- 29	743048	. CABLE ASSEMBLY, RB4 TO LAMPS					1
- 29	743049	. CABLE ASSEMBLY, RB5 TC LAMPS					1
- 29	743050	. CABLE ASSEMBLY, RB6 TC LAMPS					1
- 29	822928	. CABLE ASSEMBLY, RB1 TC LAMPS					1
- 30	2122016	. . TERMINAL, FASTON TYPE					8
- 31	370372	. CARD ASSY, DHC					8
- 32	727006	. BOARD ASSEMBLY, RESISTOR					6
- 33	438548	. SCREW, MACH, BH, 4-40 X 3/16 LG				ATT PT	12
- 34	216455	. . RESISTOR, FXD COMP, 2.7K, P/M 5% 1/4W					8
- 35	595359	. . RESISTOR, FIXED, CCME, 10C OHMS 5% 0.25W					8
- 36	727005	. . TERMINAL BOARD					1
- 37	727001	. BRACKET, RESISTOR BOARD					6
- 38	18390C	. SCREW, THD CTG, BH, 8-32 X 1/4 LG				ATT PT	12
- 39	354656	. JUMPER ASSEMBLY					16
- 40	216265	. . TERMINAL, QUICK DISCON, NCN-INS, 20AWG					2
- 41	534247C	. JUMPER ASSEMBLY, WHT 7 IN. 22AWG 2 LUG					16
- 41	5314195	. JUMPER ASSEMBLY					16
- 41	556855	. JUMPER ASSEMBLY, 6 INCH					16
- 42	596255	. . TERMINAL, SLIP ON, 24-20 AWG					2
- 43	821C63	. SUPPORT, SOCKET					1
- 44	731626	. SCREW				ATT PT	2
- 45	821098	. SUPPORT, SOCKET					1
- 46	731626	. SCREW				ATT PT	2
- 47	216286	. LABEL, NUMBERING R TO L 1 THRU 28					1



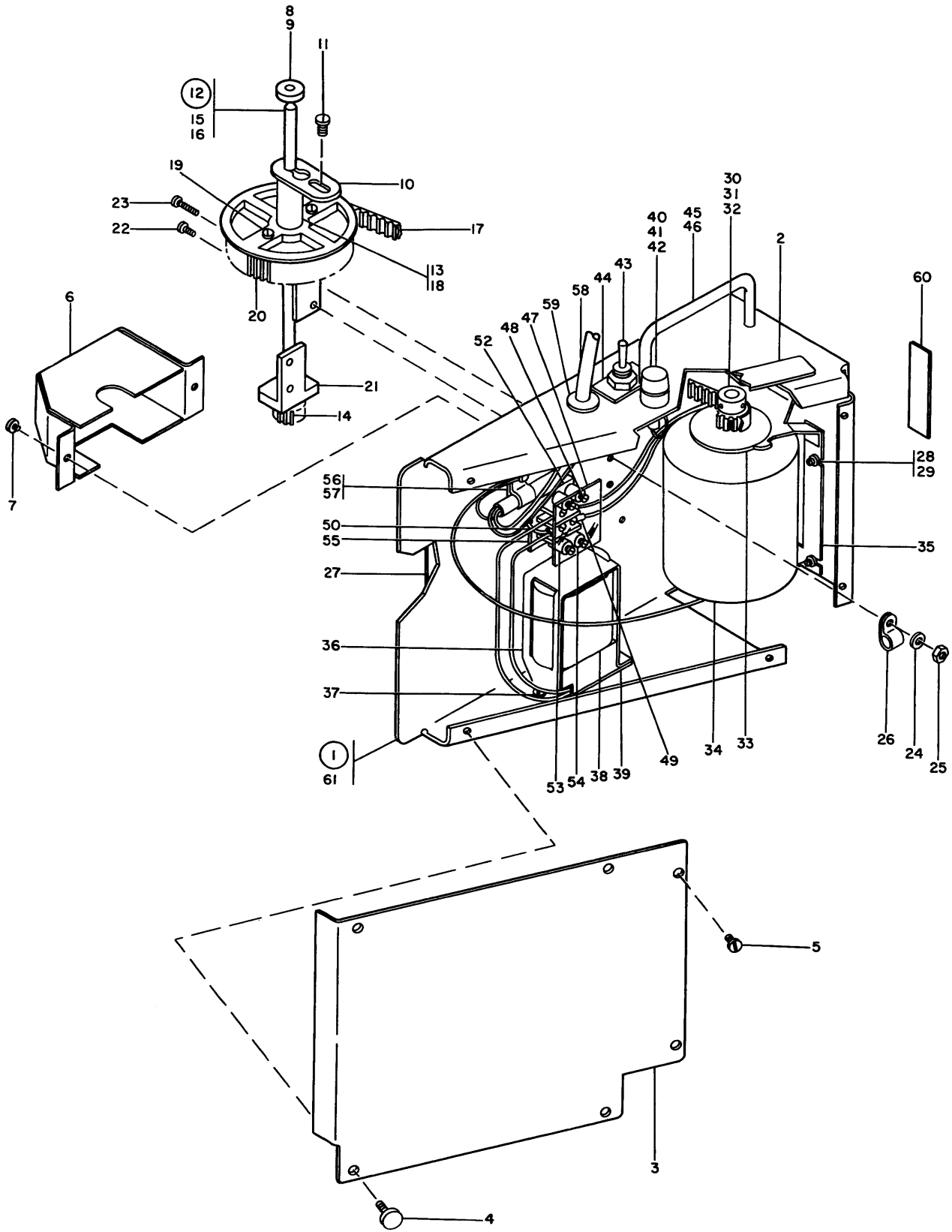

FIGURE 29. ADD MACHINE DRIVE UNIT. SEE LIST 29.

TCOLS AND TEST

LIST AND INDEX NUMBER	PART NUMBER	DESCRIPTION				UNITS PER ASM.	USABLE ON CODE
		1	2	3	4		
		ADD MACHINE DRIVE UNIT					
29 -	635491	DRIVE UNIT, ADD MACHINE				1	
- 1	616211	SEE FIGURE 29 FOR ILLUSTRATION				1	
- 2	183848	ROBOT ASSEMBLY, DRIVE UNIT				1	
- 3	616209	.. PLATE, INSTRUCTION, CURRENT REQUIREMENT				1	
- 4	306112	.. COVER, LOWER				1	
- 5	186759	.. BUMPER				4	
- 6	186759	.. SCREW, MACH, BH, 8-32 X 5/16 LG				2	
- 7	616206	.. COVER, FULLY				1	
- 8	186759	.. SCREW, MACH, BH, 8-32 X 5/16 LG				2	
- 9	113692	.. CCLLAR, SHAFT RETAINING				1	
- 10	173937	.. SETSCREW, SPLINE DR CUP PT 8-32 X 1/8 LG				1	
- 11	616201	.. STOP, SHAFT				1	
- 12	186759	.. SCREW, MACH, BH, 8-32 X 5/16 LG				1	
- 13	616203	.. SHAFT ASSEMBLY				1	
- 14	1077739	.. PIN, SPRING, 0.103 X 0.375 LG				1	
- 15	619853	.. GEAR				1	
- 16	23096	.. PIN, TAPERED, PLAIN, 1/2 LG X NO. 6				1	
- 17	616205	.. SHAFT				1	
- 18	619372	.. BELT, TIMING MAIN DRIVE				1	
- 19	616204	.. HUB, PULLEY				1	
- 20	438586	.. SCREW, MACH, UNDRCT BH, 8-32 X 7/8 LG				2	
- 21	612952	.. PULLEY, TIMING BELT				1	
- 22	619851	.. BEARING ASSEMBLY				2	
- 23	186759	.. SCREW, MACH, BH, 8-32 X 5/16 LG				3	
- 24	25627	.. SCREW, MACH, FH, 8-32 X 0.500 LG				1	
- 25	45690	.. WASHER, FL, NC.10 X 7/16 OD X 1/32 THK				1	
- 26	257189	.. NUT, HEX, 8-32				1	
- 27	169698	.. CLAMP, RELIEF				1	
- 28	804455	.. DECAL				1	
- 29	10170	.. SCREW, MACH, BH, 6-32 X 1/4 LG				4	
- 30	22478	.. WASHER, FLAT, 0.175ID X 0.375OD 0.03 THK				4	
- 31	616202	.. BUSHING, PULLEY				1	
- 32	257959	.. SETSCREW, SPLINE DR CUP PT 4-40 X 3/16 LG				2	
- 33	628308	.. PULLEY, MOTOR				1	
- 34	1132508	.. CLIP, MOTOR BRACKET				2	
- 35	1124741	.. MOTOR				1	
- 36	1124562	.. BRACKET, MOTOR				1	
- 37	1124807	.. BRACKET, CAPACITOR MOUNTING				1	
- 38	10170	.. SCREW, MACH, FH, 6-32 X 1/4 LG				2	
- 39	1106594	.. CAPACITOR, 3MFD 265VAC				1	
- 40	1124810	.. INSULATOR, CAPACITOR				1	
- 41	111264	.. FUSE, CARTRIDGE, TIME DELAY, 250V 3/4A				1	
- 42	179946	.. HOLDER, FUSE				1	
- 43	255522	.. CAP, FUSE INSULATOR				1	
- 44	73134	.. SWITCH				1	
- 45	176325	.. NAME PLATE, TOGGLE SWITCH				1	
- 46	621325	.. HANDLE, BCW				1	
- 47	186759	.. SCREW, MACH, BH, 8-32 X 5/16 LG				2	
- 48	187467	.. SHIELD, 2 POSITION				1	
- 49	210984	.. SCREW, MACH, RD HD, 6-32 X 0.250LG				1	
- 50	334921	.. TERMINAL, RING, 18-22 AWG, #6 HOLE, INS				2	
- 51	616212	.. JUMPER ASSEMBLY				2	
- 52	616213	.. JUMPER ASSEMBLY				1	
- 53	616214	.. JUMPER ASSEMBLY				1	
- 54	80817	.. TERMINAL BOARD				1	
- 55	210985	.. STUD, EXT, INT 6-32, EXT 8-32 X 0.900 LG				1	
- 56	210986	.. STUD, SHIELD MOUNTING				3	
- 57	507446	.. INSULATOR, TERMINAL STRIP				1	
- 58	183720	.. CLIP, CABLE				1	
- 59	186759	.. SCREW, MACH, FH, 8-32 X 5/16 LG				1	
- 60	1106000	.. CORD, 115V ATTACHMENT				1	
- 61	227379	.. GROMMET, RUBBER, FOR 5/8 HOLE X 1/8 PNL				1	
- 62	180528	.. PLATE, IDENTIFICATION, SERIAL NUMBER				1	
- 63	616210	.. BASE				1	
- 64	3550	FOLLOWING USED WITH PRINT UNIT					
- 65	3960	WASHER, FL- 1/4 X 9/16 OD X 0.050 THK				4	
- 66	59647	NUT, PLAIN, HEX- 1/4-20 X 7/16 FL W				2	
- 67	59652	SCREW, MACH-HEX HD 1/4-20 X 1 LG				1	
- 68	59652	SCREW, MACH-HEX HD 1/4-20 X 3/4 LG				1	
- 69	336719	FOLLOWING USED W/O PRINT UNIT					
- 70	336719	SCREW				2	
- 71	3550	WASHER, FL- 1/4 X 9/16 OD X 0.050 THK				2	

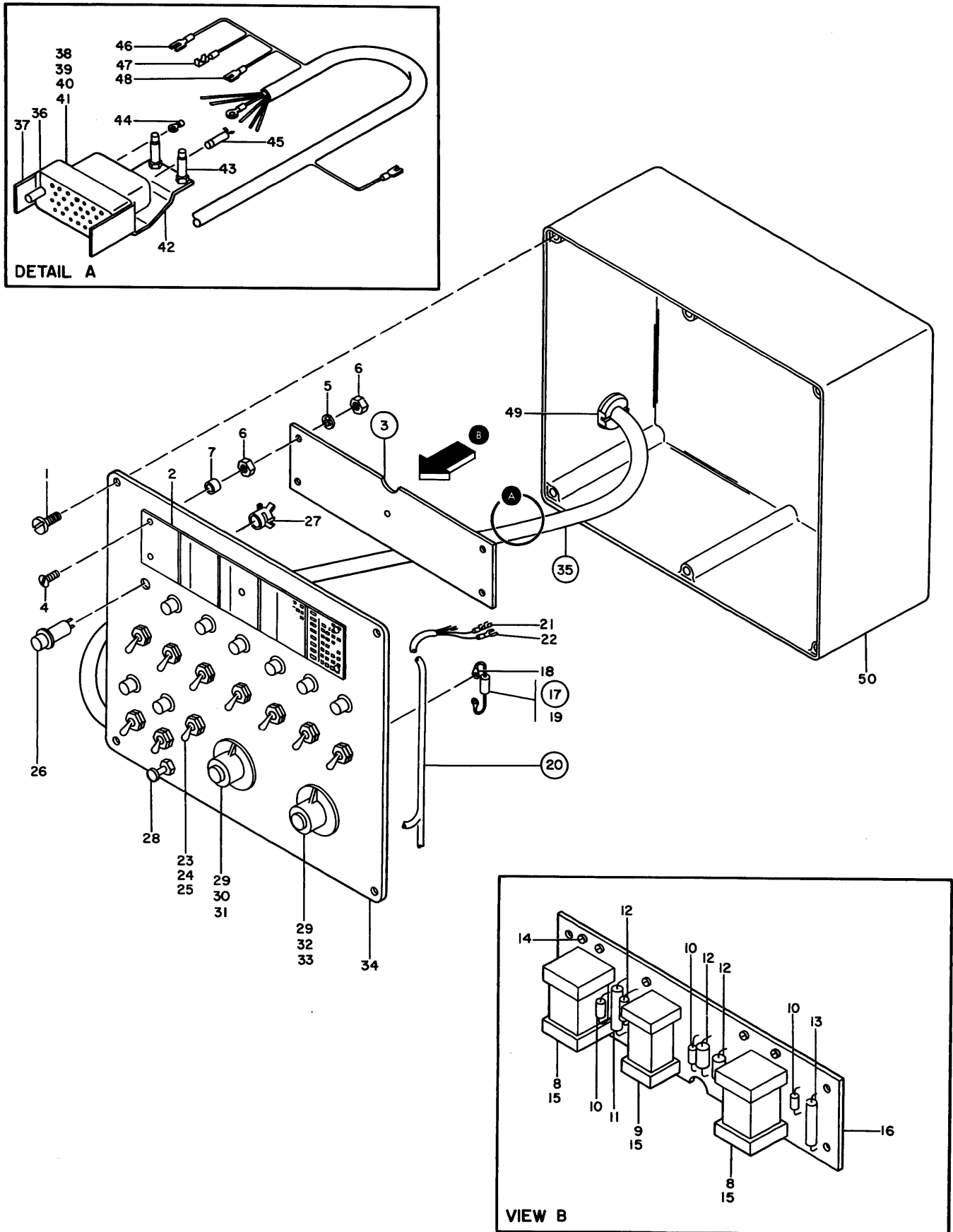

FIGURE 30. C. E. OFFLINE TEST SET. SEE LIST 30.

TOOLS AND TEST

LIST AND INDEX NUMBER	PART NUMBER	DESCRIPTION	UNITS PER ASM.	USABLE ON CODE
		1 2 3 4		
		C. E. OFFLINE TEST SET		
30 -	2156809	TEST SET, C.E. OFF LINE 1710 SEE FIGURE 30 FOR ILLUSTRATION	1	
- 1	38235	. SCREW, MACH, BH, 6-32 X 0.312 LG	4	
- 2	2161717	. LABEL	1	
- 3	2163769	. CARD ASSEMBLY, ADDRESS STROBE	1	
- 4	438559	. SCREW, MACH, PH, 4-40 X 3/4 LG	5	ATT PT
- 5	150209	. WASHER, LOCK, INT TEETH, NO. 4 X 17/64OD	5	ATT PT
- 6	37913	. NUT, HEX, 4-40	5	ATT PT
- 7	2145077	. SPACER, 0.125 ID 0.250 OD X 0.365 LONG	5	ATT PT
- 8	765665	. . RELAY, 2 POSITION	2	
- 9	765654	. . REED RELAY ASSEMBLY, 1 POINT, PLUGGABLE	1	
- 10	2111232	. . SEMICONDUCTOR DEVICE, DIODE, TYPE AM	3	
- 11	124589	. . CAPACITOR, 15MFD	1	
- 12	317006	. . RESISTOR, FXD COME, 200 OHMS, P/M 5%1/2W	3	
- 13	222084	. . CAPACITOR, 33MFD	1	
- 14	463074	. . TERMINAL, IUG	5	
- 15	483316	. . CONTACT, PLUGGABLE COMPONENT	22	
- 16	2163768	. . BOARD, CBM	1	
- 17	2101495	. RESISTOR ASSEMBLY, W/LEADS 100 OHMS 2W	7	
- 18	1092019	. . CLIP	2	
- 19	322888	. . RESISTOR, FXD COME, 100 OHMS, P/M 5% 2W	1	
- 20	2163765	. CABLE ASSEMBLY, SIOC	1	
- 21	550501	. . RECEPTACLE, TAPER PIN, 22-20 AWG	17	
- 22	186967	. . TERMINAL, SPADE, 20-24 AWG, #6 HOLE, NINS	22	
- 23	128455	. SWITCH, TOGGLE	10	
- 24	179744	. NUT, FLAIN, RD, 15/32-32 X 39/64 DIA	10	ATT PT
- 25	516910	. WASHER, LOCK, EXT TEETH, 0.478ID X 3/4OD	10	ATT PT
- 26	550511	. LAMP, INCANDESCENT, 10V 14 MA	9	
- 27	368168	. CLIP, SPEED	9	
- 28	5115388	. SWITCH, PUSH BUTTON SPDT MICRO	1	
- 29	2161719	. KNOB, ROTARY SWITCH, SINGLE POINTER	2	
- 30	2156799	. SWITCH, ROTARY	1	
- 31	2161725	. TERMINAL, SCIDEE LUG	1	
- 32	2161716	. SWITCH ASSEMBLY, ROTARY, 12 POS SHORTING	1	
- 33	322572	. WASHER, LOCK, INT TEETH, 3/8 X 0.678 OD	1	ATT PT
- 34	2156822	. PANEL, CE TEST SET	1	
- 35	2156808	. CABLE ASSEMBLY, CE OFF, LINE TEST SET	1	
- 36	2122202	. . SOCKET, GUIDE	1	
- 37	2127586	. . SPRING, LOCKING, 26 POS CONNECTOR	2	
- 38	2122837	. . CONNECTOR, PLUG, ELECTRICAL, FEMALE	1	
- 39	251570	. . SCREW, MACH, BS H, 4-40 X 0.250 LG	1	ATT PT
- 40	150209	. . WASHER, LOCK, INT TEETH, NO. 4 X 17/64OD	1	ATT PT
- 41	2114985	. . NUT, SELF LKG, HEX, 4-40 X 0.062 THK	1	ATT PT
- 42	2122839	. . CLAMP, STRAIN RELIEF	1	
- 43	37913	. . NUT, HEX, 4-40	2	ATT PT
- 44	2122259	. . TERMINAL, SOCKET CONTACT, 22-20 AWG	24	
- 45	2122261	. . SOCKET, CONTACT, 18-16 AWG	2	
- 46	334921	. . TERMINAL, RING, 18-22 AWG, #6 HOLE, INS	2	
- 47	550501	. . RECEPTACLE, TAPER PIN, 22-20 AWG	1	
- 48	186967	. . TERMINAL, SPADE, 20-24 AWG, #6 HOLE, NINS	12	
- 49	257479	. GROMMET, PLASTIC, STRAIN RELIEF	1	
- 50	2156824	. CASI, CE OFF LINE TEST SET	1	



TOOLS AND TEST

LIST AND INDEX NUMBER	PART NUMBER	DESCRIPTION	UNITS PER ASM.	USABLE ON CODE
		C. E. REMOTE BOX ASSEMBLY		
31 -	2108788	BOX ASSEMBLY, C.E. REMOTE 1301/2302 SEE FIGURE 31 FOR ILLUSTRATION	1	
- 1	2192885	. BOARD ASSEMBLY	2	
- 2	2109434	. WASHER, STUD RETAINING	2	
- 3	503592	. DICDE	10	
- 4	322310	. SWITCH, TOGGLE, DEDT 250V AC/DC 3 AMP	13	
- 5	534768	. CLAMP, LOCP, 0.380 ID	2	
- 6	58207	. SCREW, MACH, UNDRCT BH, 8-32 X 1/4 LG ATT PT	2	
- 7	2108785	. COVER, FRCNT	1	
- 8	58207	. SCREW, MACH, UNDRCT BH, 8-32 X 1/4 LG ATT PT	2	
- 9	2122194	. RELAY, 12 VOLT, 4PDT	1	
- 10	8506	. NUT, FLAIN, HEX, 3-48 X 3/16 FL W ATT PT	1	
- 11	1091111	. WASHER, LCKK, INT TEETH NC. 3 X 0.225 OD ATT PT	1	
- 12	2108787	. CABLE ASSEMBLY, CE BCX	1	
- 13	2102365	. CLAMP, LOCP, 0.330 ID	1	
- 14	2102364	. . CLAMP, IOCP, 0.220 ID 0.170 DIA MTG HOLE	1	
- 15	2123397	. . CLAMP, CABLE	1	
- 16	10170	. . SCREW, MACH, BH, 6-32 X 1/4 LG ATT PT	3	
- 17	2123282	. . BRACKET	3	
- 18	338238	. . SCREW, MACH, BH, 4-40 NC X 0.3125 LG ATT PT	9	
- 19	216210	. . SPACER, CABLE CONNECTOR	3	
- 20	216209	. . SUPPORT, CABLE CONNECTOR CARD	3	
- 21	491349	. . CARD ASSEMBLY	2	
- 22	595978	. . CARD, CABLE TERMINATOR	1	
- 23	216265	. . TERMINAL, QUICK DISCON, NCN-INS, 20AWG	26	
- 24	198982	. STOP, COVER, RUBBER	4	
- 25	2108783	. COVER, REAR	1	
- 26	2192885	. BOARD ASSEMBLY ATT PT	2	
- 27	2109434	. WASHER, STUD RETAINING ATT PT	2	
- 28	2122204	. STRIP, NUMBER	1	
- 29	2108782	. BAR, RECEPTACLE	2	
- 30	58207	. SCREW, MACH, UNDRCT BH, 8-32 X 1/4 LG ATT PT	4	
- 31	2101601	. RESISTOR ASSEMBLY	2	
- 32	596255	. . TERMINAL, SIF CN, 24-20 AWG	2	
- 33	213693	. . RESISTOR, FXD COEF, 1K, E/M 5% 1/2W	1	
- 34	216085	. GUIDE, CARD, RECEPTION LONG	2	
- 35	216083	. CARD RECEPTACLE ASSEMBLY	2	
- 36	2111680	. EXTRUSION, RUBBER	1	
- 37	2108786	. BOX, REMOTE CE	1	



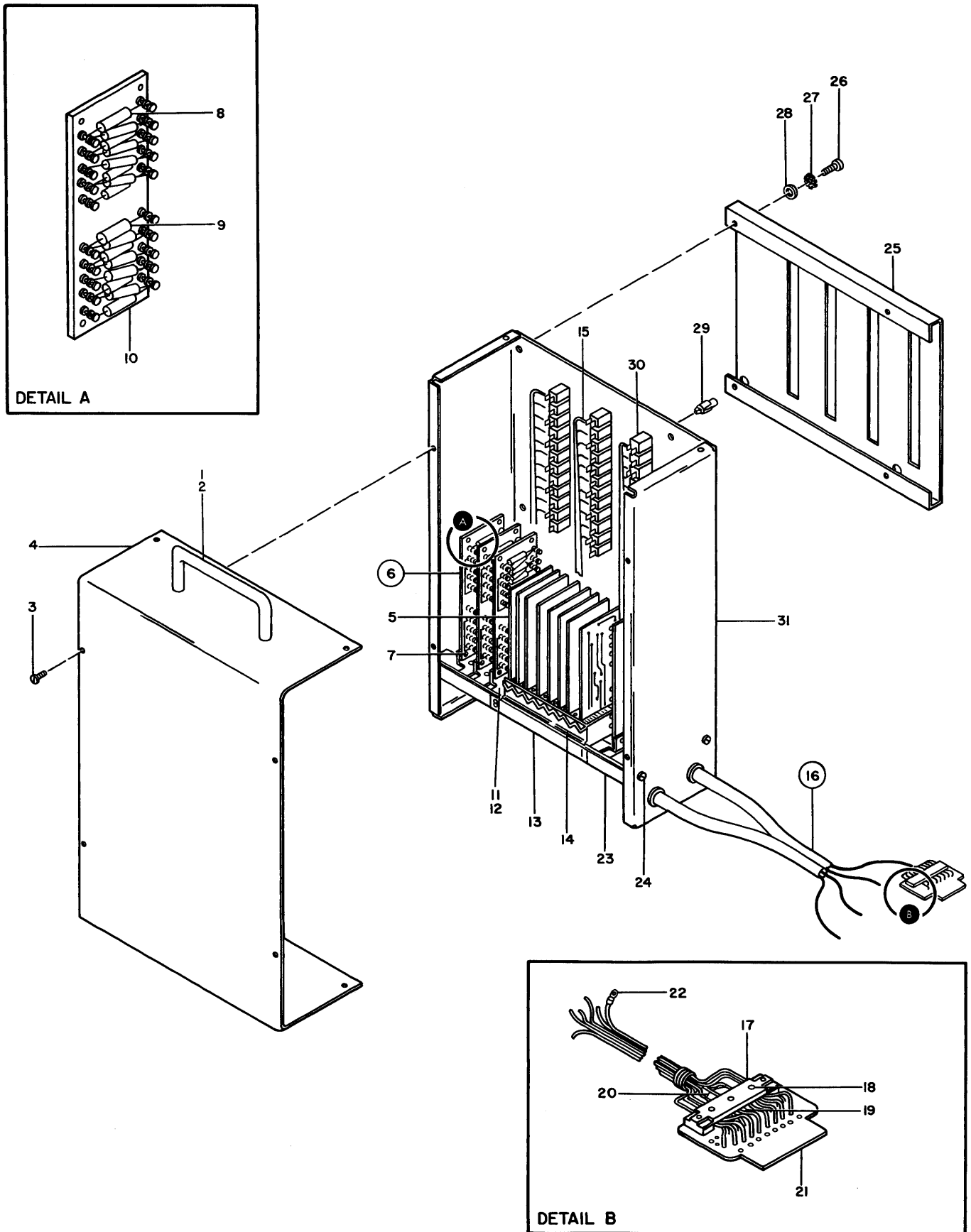

FIGURE 32. C. E. BOX ASSEMBLY. SEE LIST 32.

TCOLS AND TEST

LIST AND INDEX NUMBER	PART NUMBER	DESCRIPTION	UNITS PER ASM.	USABLE ON CODE
		C. E. BOX ASSEMBLY		
32 -	727007	BOX ASSEMBLY, C.E. 1620 SEE FIGURE 32 FOR ILLUSTRATION	1	
- 1	760156	. HANDLE, CCNECTOR RACK	1	
- 2	236849	. SCREW, MACHINE, BH, 10-32 X 1/4 LG	2	
- 3	183900	. SCREW, THD CTG, EH, 8-32 X 1/4 LG	8	
- 4	727003	. COVER, REAR	1	
- 5	370372	. CARD ASSY, DHC	8	
- 6	727006	. BOARD ASSEMBLY, RESISTOR	6	
- 7	438548	. SCREW, MACH, BH, 4-40 X 3/16 LG	12	
- 8	216448	. . RESISTOR, FXD CCMP, 1.3K, P/M 5% 1/4W	8	
- 9	595359	. . RESISTOR, FIXED, CCMP, 10C CHMS 5% 0.25W	8	
- 10	727005	. . TERMINAL BOARD	1	
- 11	727001	. BRACKET, RESISTOR BOARD	6	
- 12	183900	. SCREW, THD CTG, BH, 8-32 X 1/4 LG	12	
- 13	216286	. LABEL, NUMERING R TO L 1 THRU 28	1	
- 14	725155	. ROW ASSEMBLY, CARD RECEPTACIE	1	
- 15	726581	. CABLE ASSEMBLY, CE AID BOX	1	
- 15	726582	. CABLE ASSEMBLY, CE AID BCX	1	
- 15	726583	. CABLE ASSEMBLY, CE AID BOX	1	
- 15	726584	. CABLE ASSEMBLY, CE AID BOX	1	
- 15	726585	. CABLE ASSEMBLY, CE AID BOX	1	
- 15	726586	. CABLE ASSEMBLY, CE AID BCX	1	
- 15	726587	. CABLE ASSEMBLY, CE AID BOX	1	
- 15	725588	. CABLE ASSEMBLY	1	
- 16	726580	. CABLE ASSEMBLY, CE AID ECX	1	
- 17	216208	. . CIAMP, CABLE CCNECTOR	4	
- 18	236550	. . SCREW, MACH, BH, 4-40 X 0.375 LG	12	
- 19	216210	. . SPACER, CABLE CCNECTOR	4	
- 20	216209	. . SUPPORT, CABLE CCNECTOR CARD	4	
- 21	484351	. . CARD, CBM	4	
- 22	216265	. . TERMINAL, QUICK DISCCN, NCN-INS, 20AWG	64	
- 23	727002	. SUPPORT	2	
- 24	183900	. SCREW, THD CTG, BH, 8-32 X 1/4 LG	4	
- 25	725543	. COVER, LAMP	1	
- 26	236849	. SCREW, MACHINE, BH, 10-32 X 1/4 LG	4	
- 27	56079	. WASHER, LCCK, EXT TEETH, 0.195ID 0.410OD	4	
- 28	45690	. WASHER, FL, NC.10 X 7/16 OD X 1/32 THK	4	
- 29	369594	. LAMP, INDICATOR	48	
- 30	2122035	. SOCKETS, LIGHT MOUNTING	4	
- 31	727004	. BOX, CE	1	

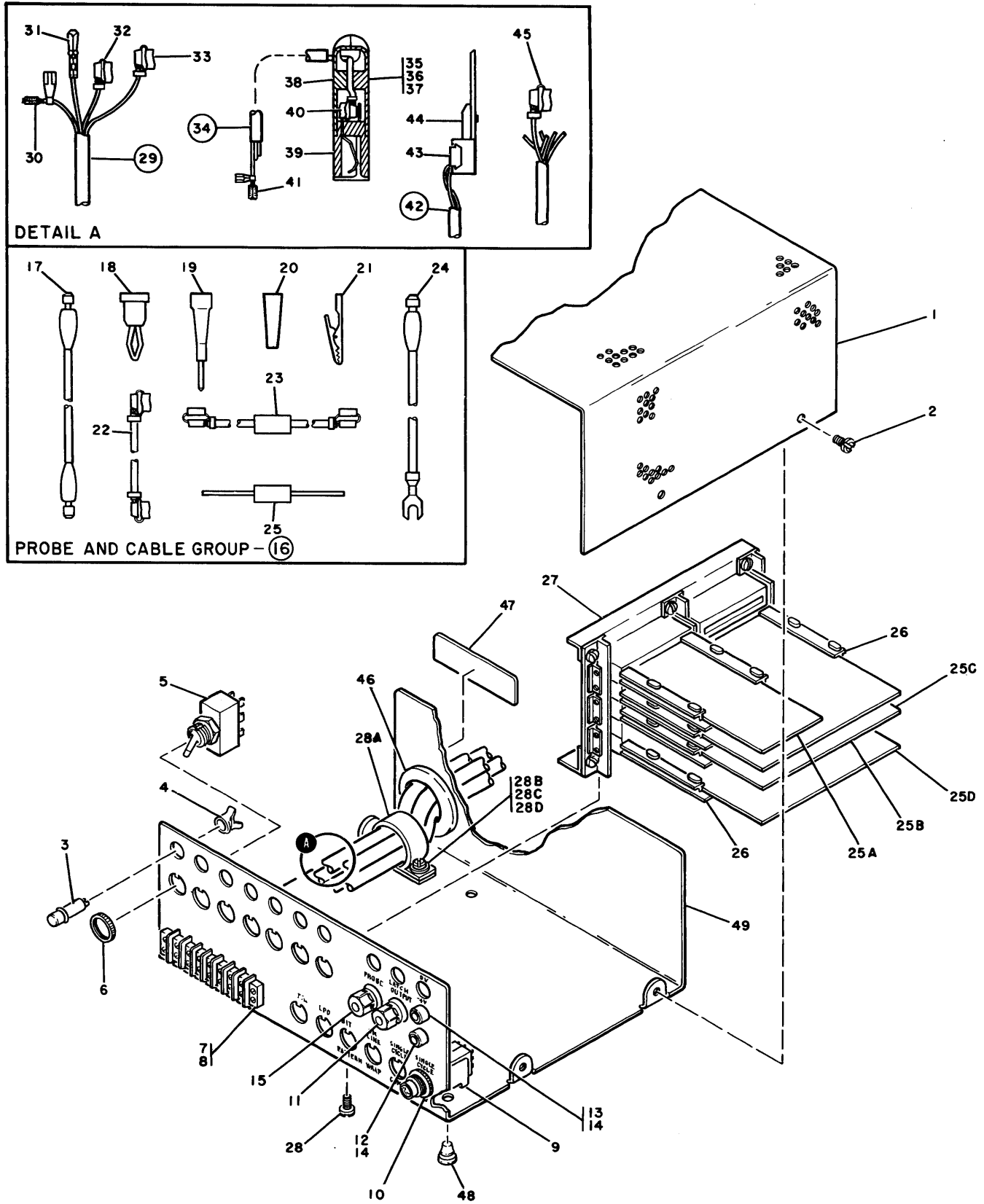

FIGURE 33. 1050 C. E. DIAGNOSTIC BOX ASSEMBLY. SEE LIST 33.

TCCLS AND TEST

LIST AND INDEX NUMBER	PART NUMBER	DESCRIPTION	UNITS PER ASM.	USABLE ON CODE
		1050 C. E. DIAGNOSTIC FOX ASSEMBLY		
33 -	822781	BOX ASSEMBLY, C.E. DIAGNOSTIC SEE FIGURE 33 FOR ILLUSTRATION	1	
- 1	822779	. COVER	1	
- 2	18390C	. SCREW, THD CTG, BH, 8-32 X 1/4 LG ATT PT	4	
- 3	550511	. LAMP, INCANDESCENT, 10V 14 MA	10	
- 4	36816E	. CLIP, SPEED	10	
- 5	734879	. SWITCH, TOGGLE, DEDT,	12	
- 6	216323	. NUT, DRESS, KNURI, 15/32-32 X 41/64 CHR ATT PT	12	
- 7	521829	. STRIP, BARRIER	1	
- 8	81693	. SCREW, MACH, BH, 6-32 X 3/8 LG ATT PT	4	
- 9	367182	. SWITCH, PUSH, 2 SFDT 125/25(V AC 5 AMP	1	
- 10	216323	. NUT, DRESS, KNURI, 15/32-32 X 41/64 CHR	1	
- 11	331065	. POST, BINDING	1	
- 12	602628	. JACK, NYLON TIP, BLACK	1	
- 13	602626	. JACK, NYLON TIP, WHITE	1	
- 14	117386	. NUT, PLAIN, HEX, 1/4-32 X 7/16 FL W ATT PT	2	
- 15	320570	. POST, BINDING, ELACK	1	
- 16	822813 NP	. PROBE AND CABLE GROUP		
- 17	451656	. . LEAD ASSEMBLY, TEST	1	
- 18	451659	. . TIP, BANANA	2	
- 19	453026	. . TIP, TEST PROFF	1	
- 20	461119	. . TIP, PROBE	6	
- 21	461159	. . CLIP	1	
- 22	725937	. . JUMPER ASSEMBLY, BLUE	3	
- 23	822751	. . RESISTOR ASSEMBLY, 8.2K, 1/2W	2	
- 24	822752	. . LEAD ASSEMBLY, TEST	5	
- 25	822884	. . DIODE ASSEMBLY	1	
- 25A	374626	. CARD ASSEMBLY	1	
- 25B	374201	. CARD ASSEMBLY	1	
- 25C	374204	. CARD ASSEMBLY	1	
- 25D	374202	. CARD ASSEMBLY	1	
- 26	216206	. GUIDE, SINGLE CARD LONG	9	
- 27	822785	. RECEPTACLE ASSEMBLY	1	
- 28	58207	. SCREW, MACH, UNRECT BH, 8-32 X 1/4 LG ATT PT	2	
- 28A	313745	. CLAMP, LOCP, 1 ID 0.204 DIA MTG HOLE	1	
- 28B	1159E	. NUT, PLAIN, HEX, 10-32 X 3/8 FL W ATT PT	1	
- 28C	55901	. WASHER, LCKK, EXT TEETH, KC.8 X 0.3810D ATT PT	1	
- 28D	45690	. WASHER, FL, NC.10 X 7/16 OD X 1/32 THK ATT PT	1	
- 29	822742	. CABLE ASSEMBLY, INT. ANALYZER	1	
- 30	209486	. . TERMINAL	37	
- 31	550501	. . RECEPTACLE, TAPER PIN, 22-20 AWG	20	
- 32	591047	. . TERMINAL, SLIP CN, 18-16 AWG	1	
- 33	596255	. . TERMINAL, SLIP ON, 24-20 AWG	38	
- 34	822743	. CABLE ASSEMBLY, NO. 1 ANALYZER	1	
- 34	822744	. CABLE ASSEMBLY, NO. 2 ANALYZER	1	
- 35	737914	. . STRAIN RELIEF, CABLE TO CARD-HALF LH	1	
- 36	38264	. SCREW, MACH, FII H, 4-40 X 3/8 LG ATT PT	2	
- 37	37913	. . NUT, HEX, 4-40 ATT PT	2	
- 38	737915	. . STRAIN RELIEF, CABLE TO CARD-HALF RH	1	
- 39	737916	. . CCNNECTOR ASM, RECP-CABIE TC CARD	1	
- 40	596255	. . TERMINAL, SLIP CN, 24-20 AWG	AR	
- 41	209486	. . TERMINAL	AR	
- 42	822745	. CABLE ASM, NO. 3 ANALYZER	1	
- 42	822746	. CABLE ASM, NO. 4 ANALYZER	1	
- 42	822747	. CABLE ASM, NO. 5 ANALYZER	1	
- 43	216300	. . PLUG, STRAIN RELIEF	1	
- 44	216304	. . STRAIN RELIEF	1	
- 45	596255	. . TERMINAL, SLIP CN, 24-20 AWG	AR	
- 46	198981	. GRMMET, RUBBER	1	
- 47	1E0528	. PLATE, IDENTIFICATION, SERIAL NUMBER	1	
- 48	1070160	. STOP	4	
- 49	822780	. BASE	1	

TOOLS AND TEST

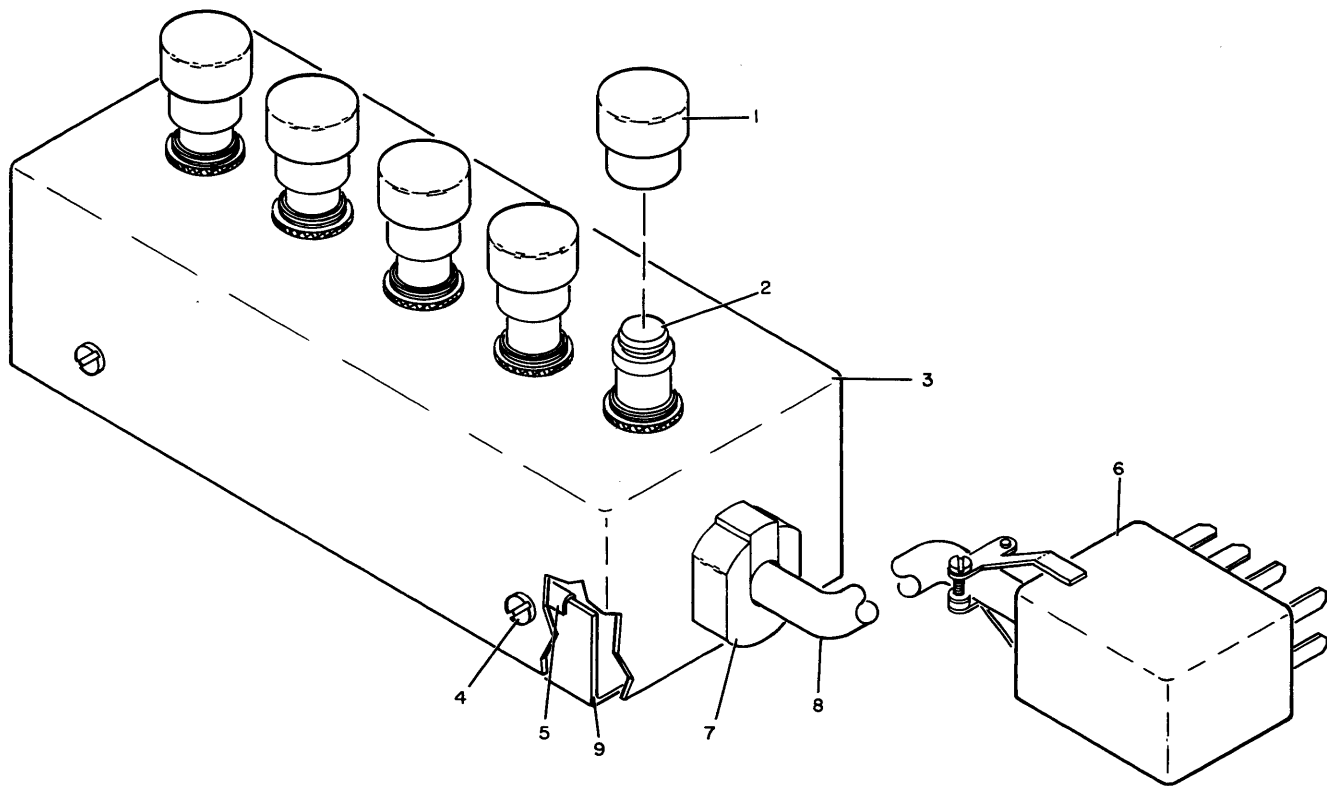

FIGURE 34. 305 SYNC PANEL REMOTE BOX ASSEMBLY. SEE LIST 34.

LIST AND INDEX NUMBER	PART NUMBER	DESCRIPTION				UNITS PER ASM.	USABLE ON CODE
		1	2	3	4		
		305 SYNC PANEL REMOTE BOX ASSEMBLY					
34 -	21C0937					1	
- 1	189138					5	
- 2	189136					5	
- 3	211438E					1	
- 4	801391					4	
- 5	21C9834					4	
- 6	359553					1	
- 7	1C7611					1	
- 8	2100317					1	
- 9	2114389					1	

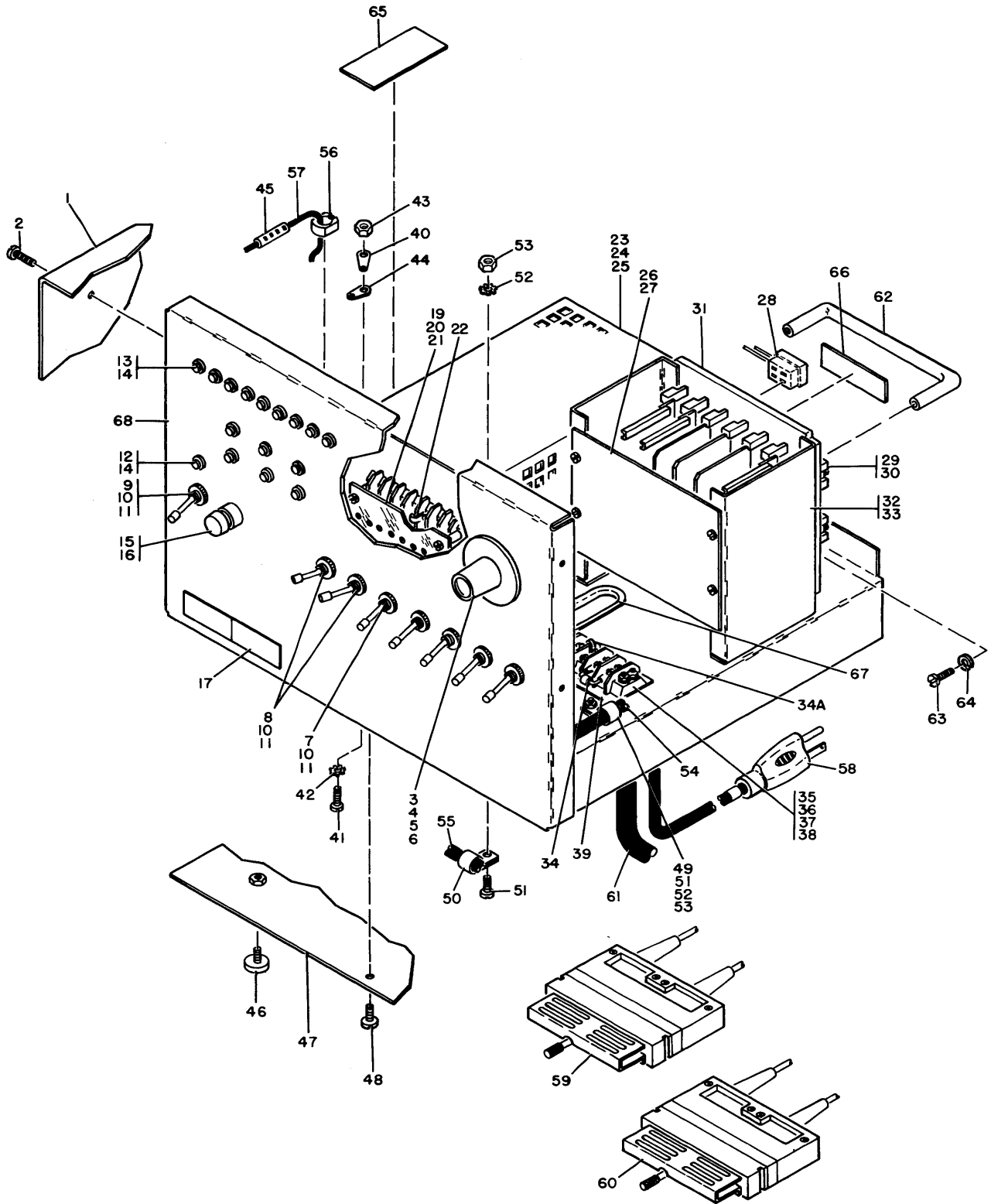

FIGURE 35. MANUAL INTERFACE TESTER (MIT). SEE LIST 35.

TCOLS AND TEST

LIST AND INDEX NUMBER	PART NUMBER	DESCRIPTION	UNITS PER ASM.	USABLE ON CODE
		MANUAL INTERFACE TESTER (MIT)		
35 -	453670	MANUAL INTERFACE TESTER (MI) SEE FIGURE 35 FOR ILLUSTRATION	1	
- 1	5495041	. COVER	1	
- 2	10170	. SCREW,MACH-BIND HD 6-32 X 1/4 LG	6	
- 3	847110	. KNOB	2	
- 4	824483	. SWITCH	2	
- 5	824486	. NUT,HEX- .375-32	4	
- 6	322572	. WASHER,LOCK- 3/8 X 0.678 CD	4	
- 7	725347	. SWITCH,TOGGLE SPDT	5	
- 8	725348	. SWITCH,TOGGLE DPDT	2	
- 9	550777	. SWITCH,TOGGLE	1	
- 10	216323	. NUT,DRESS,KNURT-15/32-32 X 41/64 CHROME	8	
- 11	159373	. WASHER,LOCK-15/32 ID X 3/4 CD	8	
- 12	5353890	. LAMP,INDICATOR	1	
- 13	5353889	. LAMP,INDICATOR	15	
- 14	5353887	. HOLDER	16	
- 15	111264	. FUSE- 3/4A	1	
- 16	179546	. HOLDER,FUSE	1	
- 17	5495138	. NAMEPLATE	1	
- 19	550788	. SHIELD	1	
- 20	10170	. SCREW,MACH-BIND HD 6-32 X 1/4 LG	1	
- 21	210883	. STUD-SHIELD MTG,TAPPED,NO. 6-32	1	
- 22	367115	. JUMPER	1	
- 23	5495049	. SUPPLY,POWER	1	
- 24	186759	. SCREW,MACH-BIND HD 8-32 X 5/16 LG	4	
- 25	60646	. WASHER,LOCK-INT T. NO.8	4	
- 26	5495043	. RETAINER,CARD	1	
- 27	10170	. SCREW,MACH-BIND HD 6-32 X 1/4 LG	4	
- 28	5495045	. CROSSOVER,VOLTAGE SLT	1	
- 29	813179	. CLAMP	4	
- 30	2123354	. SCREW	4	
- 31	5495039	. BOARD,SLT	1	
- 32	5495042	. BRACKET	2	
- 33	10170	. SCREW,MACH-BIND HD 6-32 X 1/4 LG	4	
- 34	5495141	. RESISTOR,JUMPER	1	
- 34a	367115	. JUMPER	1	
- 35	317485	. BLOCK,TERM	1	
- 36	322065	. SCREW,MACH-BIND HD 6-32 X 5/8 LG	4	
- 37	56722	. WASHER,LOCK-EYE TEETH NC.6	4	
- 38	257187	. NUT,PLAIN,HEX- 6-32	4	
- 39	527916	. STRIP,MARKER	1	
- 40	2248047	. TERMINAL	1	
- 41	25627	. SCREW-BD. ED 8-32 X .500 LG	1	
- 42	55901	. LOCKWASHER-NC. 8 X 0.381CD .168ID .023	1	
- 43	257189	. NUT,HEX- 8-32	1	
- 44	483681	. TERMINAL	1	
- 45	602603	. SPLICE,WIRE	1	
- 46	95834	. FOOT	1	
- 47	5495044	. COVER,BOTTOM	1	
- 48	10170	. SCREW,MACH-BIND HD 6-32 X 1/4 LG	2	
- 49	804109	. CLAMP,CABLE	1	
- 50	101922	. CLAMP,CABLE	1	
- 51	25627	. SCREW-BD HD 8-32 X .500 LG	2	
- 52	55901	. WASHER,LOCK-NO.8 X 0.381CD .168ID .023	2	
- 53	257189	. NUT,HEX- 8-32	2	
- 54	5495046	. CABLE	1	
- 55	5495047	. CABLE	1	
- 56	1138167	. BUSHING,STRAIN RELIEF	1	
- 57	5442687	. POWER CORD ASM	1	
- 58	5442687	. POWER CORD ASM	1	
- 59	5440650	. CONNECTOR ASSEMBLY	1	
- 60	5440649	. CONNECTOR ASSEMBLY	1	
- 61	5495047	. CABLE	1	
- 62	438267	. HANDLE	1	
- 63	75449	. SCREW,CAP,SOC HD- 10-32 X 3/8 LG	2	
- 64	9092	. WASHER,LOCK- .194 ID .337 CD	2	
- 65	369267	. LABEL	1	
- 66	5162745	. TAG,VOLTAGE	1	
- 67	5495140	. GRCMMET	1	
- 68	5495040	. WELD,CHASSIS	1	

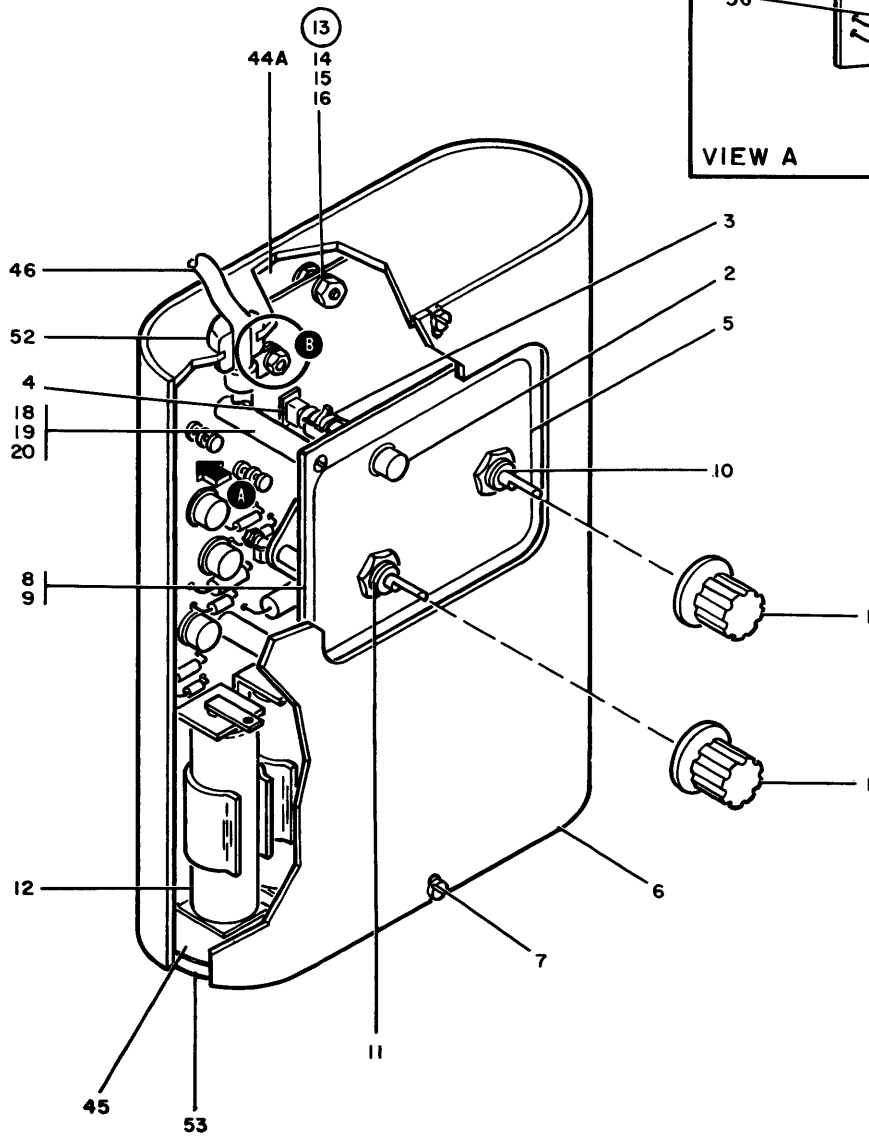
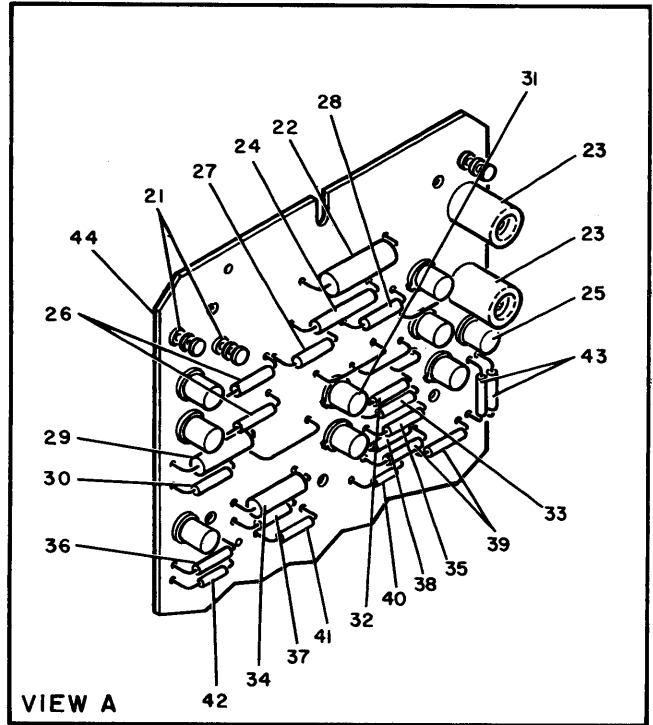
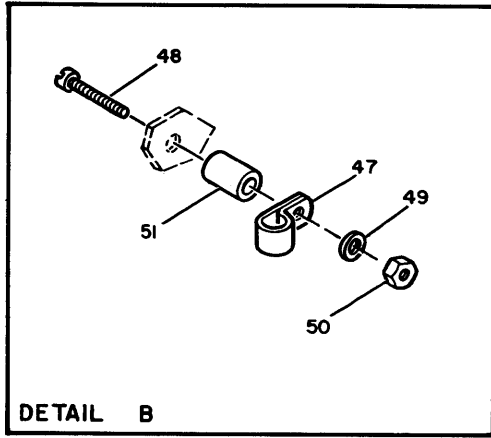

FIGURE 36. MARGINAL CHECK CONTROL UNIT ASSEMBLY. SEE LIST 36.



TOOLS AND TEST

LIST AND INDEX NUMBER	PART NUMBER	DESCRIPTION				UNITS PER ASM.	USABLE ON CODE
		1	2	3	4		
		MARGINAL CHECK CONTROL UNIT ASSEMBLY					
36 -	5712439	MARGINAL CHECK CONTROL UNIT ASSEMBLY SEE FIGURE 36 FOR ILLUSTRATION				1	
- 1	5712451	. KNOB				2	
- 2	5712461	. LAMP, INCANDESCENT, CLEAR, 14MA 10V				1	
- 3	368168	. CLIP, SPEED				1	
- 4	195CCC	. CONNECTOR, IAME, 2 PIN				1	
- 5	5712445	. NAMEPLATE				1	
- 6	5712441	. COVER				1	
- 7	91373	. SCREW, MACH, BH 3-48 X 0.250 LG				2	ATT PT
- 8	5712442	. PANEL, CONTRCL				1	
- 9	52522	. SCREW, MACH, PH, 4-40 X 5/16 LG				4	ATT PT
- 10	5712452	. RESISTOR, VAR, 2.5K CHMS E/M 20% 1/2W				1	
- 11	5712454	. SWITCH, RCTARY, NCKSHCET, 3-POLE, 3-POS				1	
- 12	5712455	. BATTERY, 4.2V				5	
- 13	5712469	. CARD ASSEMBLY, CCMFCNENT				1	
- 14	322065	. SCREW, MACH, BH, 6-32 X 5/8 LG				2	ATT PT
- 15	257986	. WASHER, FIAT, NC. 6 X 0.312 OD				4	ATT PT
- 16	38051	. NUT, PLAIN, HEX, 6-32 X 1/4 FL W				6	ATT PT
- 18	338238	. SCREW, MACH, BH, 4-40 NC X 0.3125 LG				4	ATT PT
- 19	257985	. WASHER, FI NC.4 X C.250 OD X 0.028 THK				4	ATT PT
- 20	5712443	. SPACER, 0.375 ID X 1/4 OD X 1.06 LG				4	ATT PT
- 21	317142	. . TERMINAL, STUD, NCNINSULATED DEL TURRET				3	
- 22	521737	. . CAPACITOR, ALUM, ELEC 50MFD 12V				1	
- 23	5712453	. . RESISTOR, VARIABLE, 2.5K E/M 20% 1/4W				2	
- 24	217074	. . CAPACITOR, POLY, FILM, 0.056MFD 100VDC				1	
- 25	318324	. . TRANSISTOR, TYPE 033				8	
- 26	321271	. . RESISTOR, FXD CCME, 10 CHMS, P/M 5% 1/2W				2	
- 27	213536	. . RESISTOR, 100 CHMS, 1/2W				1	
- 28	317023	. . RESISTOR, FXD COMP, 4.3K, P/M 5% 1/2W				1	
- 29	451278	. . RESISTOR, FIXED, CCME, 27 OHM 5% 1W				1	
- 30	317028	. . RESISTOR, FXD CCME, 18K, E/M 5% 1/2W				1	
- 31	2414977	. . TRANSISTOR				1	
- 32	317276	. . RESISTOR, FXD CCME, 1.2K E/M 5% 1/2W				1	
- 33	55002C	. . RESISTOR, FIXED, CCME, 1K 1% 1/8W				1	
- 34	528946	. . RESISTOR, FILM, 1050 CHMS P/M 1% 1/4W				1	
- 35	452493	. . RESISTOR, FILM, 1.78K OHMS P/M 1% 1/8W				1	
- 36	4524C5	. . RESISTOR, FILM, 499 OHMS E/M 1% 1/8W				1	
- 37	213693	. . RESISTOR, FXD CCME, 1K, P/M 5% 1/2W				1	
- 38	317021	. . RESISTOR, FXD CCME, 2.7K, P/M 5% 1/2W				1	
- 39	479125	. . RESISTOR, FXD FILM, 2.8K, P/M 1% 1/8W				2	
- 40	369679	. . DIODE, SEMICONDUCTOR, ZENER, TYPE GA				1	
- 41	479087	. . RESISTOR, FXD FILM, 549 CHMS, P/M 1% 1/8W				1	
- 42	369611	. . DIODE, SEMICONDUCTOR-ZENER, TYPE DY				1	
- 43	31702C	. . RESISTOR, FXD CCME, 2.2K, P/M 5% 1/2W				2	
- 44	5709247	. . CAB				1	
- 44A	5712446	. INSULATION				1	
- 45	5712447	. INSULATION, BATTERY				1	
- 46	5712456	. CORD AND PLUG				1	
- 47	5213276	. CLAMP, CABLE				1	
- 48	322551	. SCREW, MACH, BH, 6-32X3/4 LG				1	ATT PT
- 49	257986	. WASHER, FIAT, NC. 6 X 0.312 OD				1	ATT PT
- 50	38051	. NUT, PLAIN, HEX, 6-32 X 1/4 FL W				1	ATT PT
- 51	1091434	. SLEEVE, 5/32 ID X 9/32 CD X 5/16 THK				1	
- 52	5712463	. BRACKET				1	
- 53	5712440	. CASE				1	

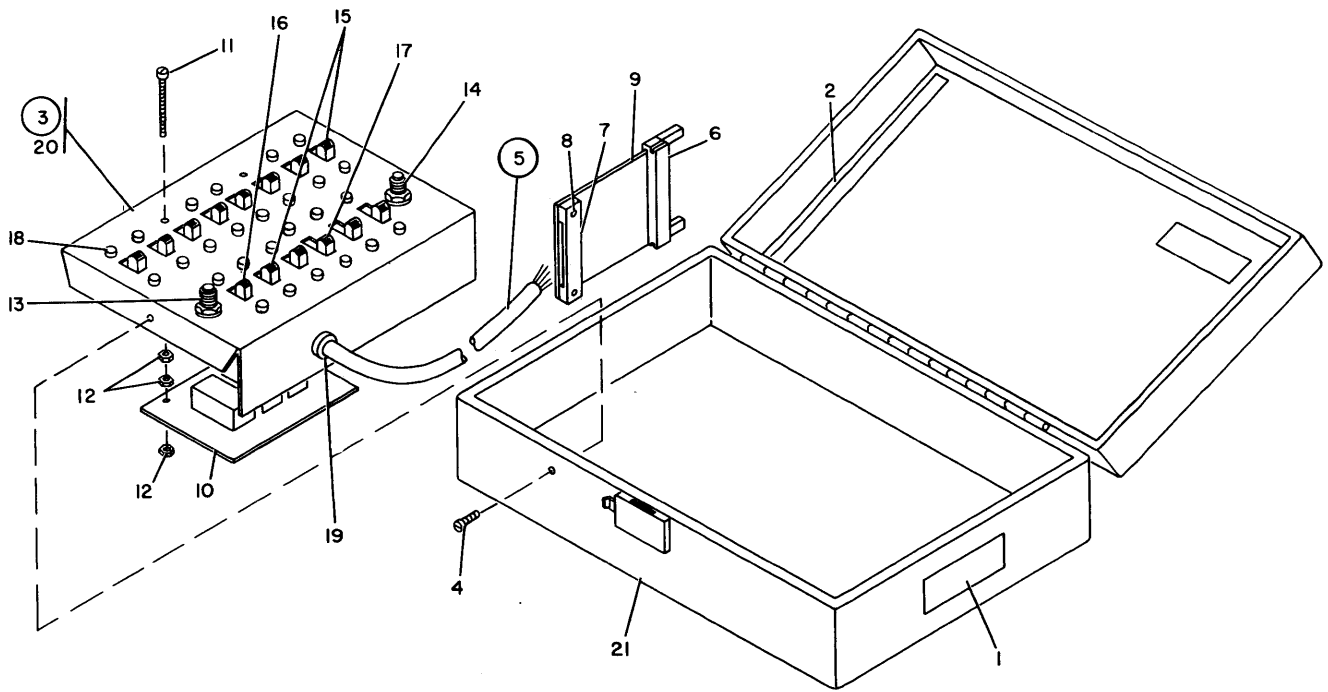

FIGURE 37. 44RK CE CONTROL BOX ASSEMBLY. SEE LIST 37.

LIST AND INDEX NUMBER	PART NUMBER	DESCRIPTION				UNITS PER ASM.	USABLE ON CODE
		1	2	3	4		
		44RK CE CONTROL BOX ASSEMBLY					
37 -	2200054	BOX ASM, 44RK CE CONTROL SEE FIGURE 37 FOR ILLUSTRATION				1	
- 1	2156266	. TAG, SERIAL				1	
- 2	221909C	. DECAL, ADDRESS WARNING				1	
- 3	2156230	. PANEL ASSEMBLY, 44 RK, CE CONTROL				1	
- 4	322550	. SCREW, MACH, BH, 6-32 X 1/2 LG ATT PT				2	
- 5	2156236	. . . CABLE ASSEMBLY				1	
- 6	811804	. . . GUIDE, CARD				1	
- 7	2180973	. . . CLAMP, SLT CARD				4	
- 8	2204180	. . . RIVET ATT PT				4	
- 9	2156239	. . . CONNECTOR, CARD				1	
- 10	2156238	. . . CARD				1	
- 11	438556	. . . SCREW, MACH, UNDRCT BH, 4-40 X 1-1/2 ATT PT				2	
- 12	37913	. . . NUT, HEX, 4-40 ATT PT				6	
- 13	2156235	. . . SWITCH, PUSH BUTTON, SPDT				1	
- 14	2156234	. . . SWITCH, PUSH BUTTON, SPST, NORM OPEN				1	
- 15	2156231	. . . SWITCH, SLIDE, SEST				9	
- 16	2156232	. . . SWITCH, SLIDE, DEDT				2	
- 17	2156233	. . . SWITCH, SLIDE, DEDT				3	
- 18	612781	. . . RIVET, SOLID, 0.124 DIA X 0.140 IN. LG ATT PT				26	
- 19	1138167	. . . BUSHING, STRAIN RELIEF				1	
- 20	2156228	. . . PANEL				1	
- 21	2156229	. . . BOX				1	

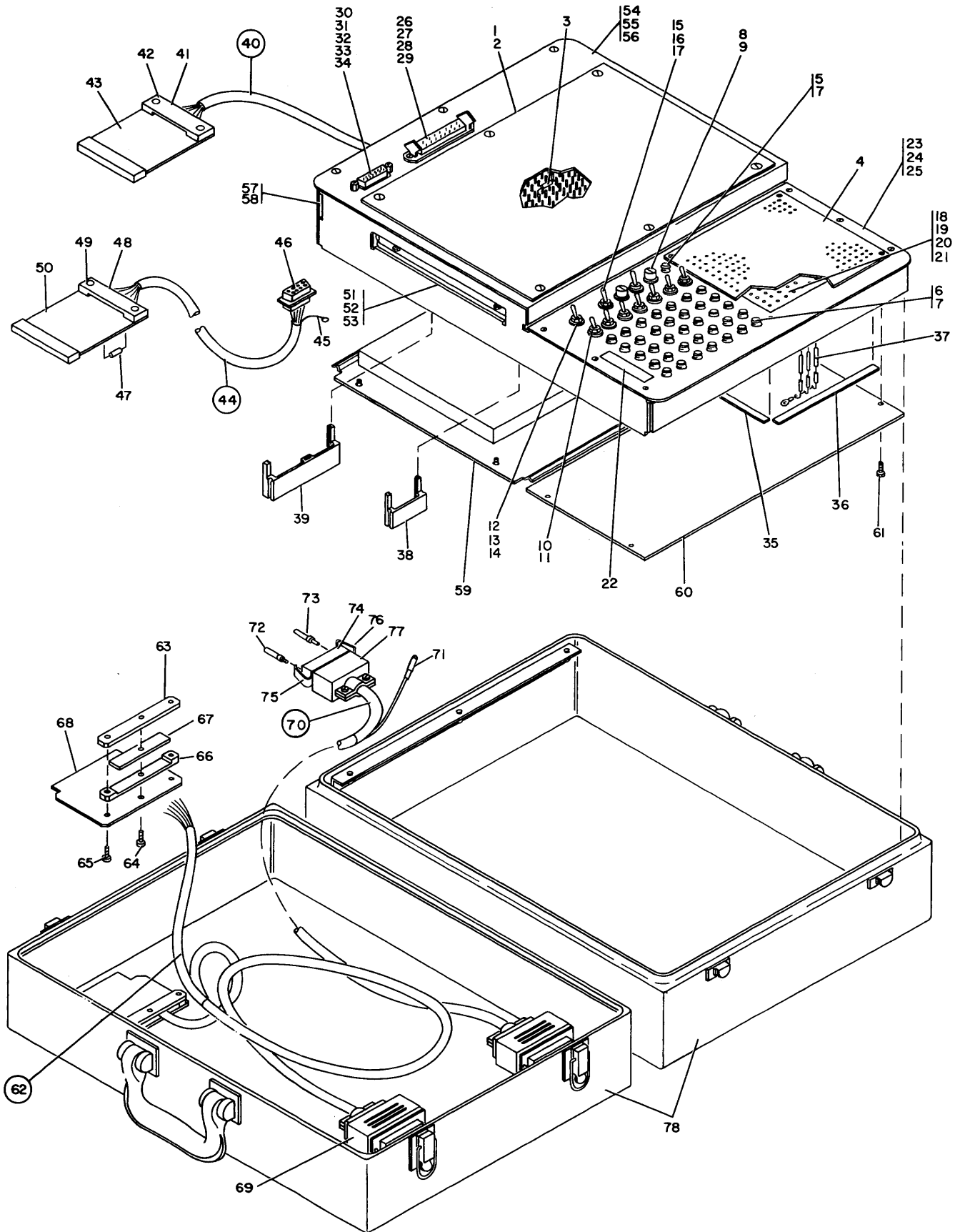

FIGURE 38. UNIVERSAL TELEPROCESSING TESTER ASSEMBLY. SEE LIST 38.

TOOLS AND TEST

LIST AND INDEX NUMBER	PART NUMBER	DESCRIPTION	UNITS PER ASM.	USABLE ON CODE
		UNIVERSAL TELEPROCESSING TESTER ASSEMBLY		
38 -	453611	tester ASSEMBLY, UNIVERSAL TELEPROCESSING SEE FIGURE 38 FOR ILLUSTRATION	G 1	
- 1	5442731	. COVER	1	
- 2	10170	. SCREW, MACH, BH, 6-32 X 1/4 LG	6	
- 3	5442798	. CAPACITOR ASSEMBLY	1	
- 4	5442726	. PLATE	1	
- 5	5362323	. INDICATOR ASSEMBLY, RED	1	
- 6	5362325	. INDICATOR ASSEMBLY, CLEAR	35	
- 7	5353887	. HOUSING, LAMP	36	
- 8	5442736	. SWITCH	2	
- 9	5442809	. NUT	2	
- 10	9900432	. SWITCH	8	
- 11	5442809	. NUT	8	
- 12	5442807	. CAP	1	
- 13	5442735	. SWITCH	1	
- 14	5442809	. NUT	1	
- 15	5442808	. CAP	1	
- 16	5442735	. SWITCH	1	
- 17	5442734	. NUT	1	
- 18	5442727	. PLUGBOARD	1	
- 19	322552	. SCREW, MACH, BH, 6-32 X 7/8 LG	4	
- 20	257986	. WASHER, FIAT, NC. 6 X 0.312 OD	4	
- 21	344015	. NUT, SELF LKG, HEX, 6-32 X 5/16 FL W	4	
- 22	5442745	. NAMEPLATE	1	
- 23	5442765	. PANEL	1	
- 24	81693	. SCREW, MACH, BH, 6-32 X 3/8 LG	6	
- 25	344015	. NUT, SELF LKG, HEX, 6-32 X 5/16 FL W	6	
- 26	5708684	. CONNECTOR	1	
- 27	91373	. SCREW, MACH, BH 3-48 X C.250 LG	2	
- 28	37066	. WASHER, ICCK, SPLIT, NC. 3 X 0.212 OD	2	
- 29	8506	. NUT, FLAIN, HEX, 3-48 X 3/16 FL W	2	
- 30	385951	. CONNECTOR	1	
- 31	5302396	. SHAFT, JACK, 4-40	2	
- 32	1127741	. SPACER, 0.116 ID X 3/16 CD X 1/32 THK	2	
- 33	257984	. WASHER, ICCK, SPLIT, 1/8 ID X 13/64 OD	2	
- 34	37913	. NUT, HEX, 4-40	2	
- 35	5442723	. STRIP, MARKER	1	
- 36	5442725	. STRIP, MARKER	1	
- 37	5442737	. BUS ASSEMBLY, DICDE	15	
- 38	811802	. GUIDE, CARD	10	
- 39	811804	. GUIDE, CARD	18	
- 40	5442751	. CABLE ASM, SWITCHES TO 01A-A1 POS A5	1	
- 40	5442753	. CABLE ASM, PLUG BOARD TO C1A-A1 POS N4	1	
- 40	5442752	. CABLE ASM, PLUG BOARD TO C1A-A1 POS N3	1	
- 40	5442750	. CABLE ASM, INDICATORS TO 01A-A1 POS A6	1	
- 40	5442748	. CABLE ASM, T5, T6 TO J1 INTERFACE	1	
- 40	5442747	. CABLE ASM, PLUG BOARD TO C1A-A1 POS T3	1	
- 40	5442746	. CABLE ASM, PLUG BOARD TO C1A-A1 POS T2	1	
- 40	5442744	. CABLE ASM, PLUGBOARD TO 01A-A1 POS T1	1	
- 40	5442742	. CABLE ASM, INDICATORS TO C1A-A1 POS A7	1	
- 40	5442743	. CABLE ASM, PLUGBOARD TO 01A-A1 POS A4	1	
- 41	5275481	. . STRAIN RELIEF	1	
- 42	5275486	. . RIVET	1	
- 43	5800634	. . CAB ASSEMBLY	1	
- 44	5442749	. CABLE ASM, 01A-A1 POS T7 TO POS J2	1	
- 45	804715	. . TERMINAL, IUG, INS, 18/22AWG NO.4 MTG HOLE	1	
- 46	5495085	. . CONNECTOR, MINATURE, FEMALE	1	
- 47	216482	. . RESISTOR, FXD, 39K, 1/4W	1	
- 48	5275481	. . STRAIN RELIEF	1	
- 49	5275486	. . RIVET	2	
- 50	5800634	. . CAB ASSEMBLY	1	

TOOLS AND TEST

LIST AND INDEX NUMBER	PART NUMBER	DESCRIPTION				UNITS PER ASM.	USABLE ON CODE
		1	2	3	4		
		NEW SELECTRIC TESTER (NEST)					
46 -	453556	NEW SELECTRIC TESTER-NEST SEE FIGURE 46 FOR ILLUSTRATION				1	
- 1	5495038	. CABLE ASSEMBLY, INTERFACE				1	
- 2	NO NO.	. MAINT. MANUAL FORM NO. FEMM Y27-0089-0				1	
- 3	NO NO.	. LABEL, VOLTAGE				1	
- 4	5495301	. PANEL ASM				1	
- 5	32042	. SCREW, MACH, BH, 10-32 X 3/8 LG				6	
- 6	5495315	. . COVER ASSEMBLY				1	
- 7	32042	. . SCREW, MACH, BH, 10-32 X 3/8 LG				6	
- 8	5495318	. . NAMEPLATE				1	
- 9	5495378	. . PLATE				1	
- 10	251970	. . SCREW, MACH, BS H, 4-40 X 0.250 LG				2	
- 11	5495321	. . CABLE				1	
- 12	107611	. . BUSHING				1	
- 13	483677	. . TERMINAL, RING, 18 TO 20 AWG				1	
- 14	81693	. . SCREW, MACH, BH, 6-32 X 3/8 LG				1	
- 15	62031	. . WASHER, LOCK, INT TEETH, NO.6 X 0.295 OD				1	
- 16	460628	. . RECEPTACLE				1	
- 17	332620	. . SCREW, MACH, BH 10-32 X 1/2 LG				2	
- 18	9092	. . WASHER, LOCK, SPLIT RING, 0.194ID 0.3370				2	
- 19	11598	. . NUT, FLAIN, HEX, 10-32 X 3/8 PL W				2	
- 20	338165	. . FUSE				1	
- 21	303549	. . FUSE, CARTRIDGE, SLOW BLOW, 250V 1A				1	
- 22	76521	. . FUSE POST				2	
- 23	2122254	. . BLOCK, FEMALE, 20 POSITION				1	
- 24	2122203	. . PIN, GUIDE, BRASS, SUPPLIED W/HARDWARE				1	
- 25	2122202	. . SOCKET, GUIDE				1	
- 26	2127985	. . CATCH, LOCKING				2	
- 27	2122472	. . CONNECTOR, 50 PLACE FEMALE				1	
- 28	2122734	. . PIN, GUIDE, CORNER, 34 AND 50 POS CONN				2	
- 29	2122735	. . SOCKET, GUIDE, CORNER, 34 & 50 POS CONN				2	
- 30	2127985	. . CATCH, LOCKING SPRING				2	
- 31	1160977	. . CONNECTOR				1	
- 32	251283	. . SCREW, MACH, FII H, 4-40 X 3/4 LG				2	
- 33	5495331	. . BLOCK				1	
- 34	338238	. . SCREW, MACH, BH, 4-40 NC X 0.3125 LG				2	
- 35	257985	. . WASHER, FI NO.4 X 0.250 OD X 0.028 THK				2	
- 36	257984	. . WASHER, LOCK, SPLIT, 1/8 ID X 13/64 OD				2	
- 37	734879	. . SWITCH, TOGGLE, DEDT				2	
- 38	835273	. . SWITCH, POWER				1	
- 39	216323	. . NUT, DRESS, KNURL, 15/32-32 X 41/64 CHR				3	
- 40	159373	. . WASHER, LOCK, EXT TEETH, 15/32ID X 3/4OD				3	
- 41	5376712	. . INDICATOR ASSEMBLY, WHITE, 24V				2	
- 42	5362323	. . INDICATOR ASSEMBLY, RED				5	
- 43	5362324	. . INDICATOR ASSEMBLY, AMBER 10V				6	
- 44	5353888	. . HOUSING, INDICATOR				13	
- 45	5495327	. . KNOB				2	
- 46	5495383	. . SWITCH				1	
- 47	5495306	. . TEST JACK				4	
- 48	5495336	. . SWITCH				3	
- 49	5442805	. . NUT				3	
- 50	5495326	. . KNOB				3	
- 51	5495338	. . SWITCH				1	
- 52	5495334	. . POTENTIOMETER				1	
- 53	5495333	. . POTENTIOMETER				1	

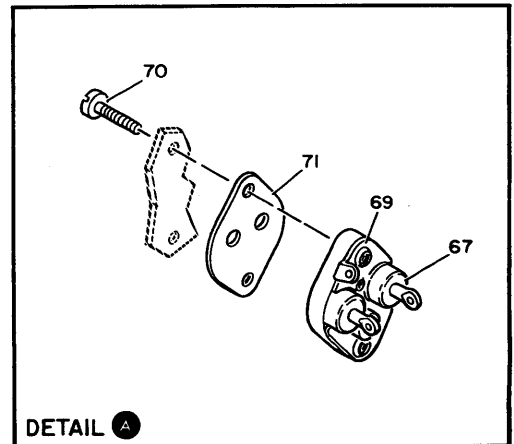
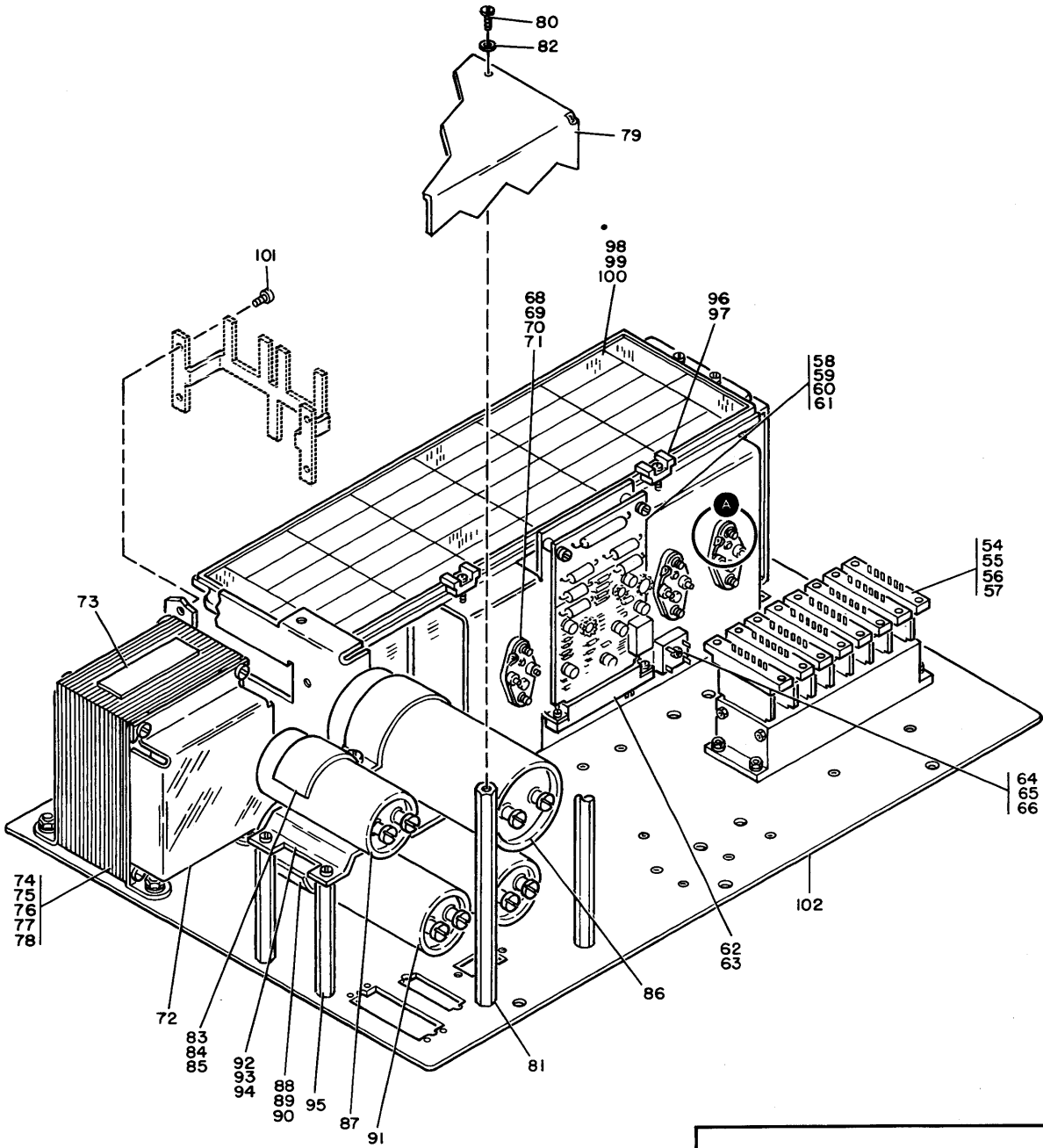

FIGURE 46. NEW SELECTRIC TESTER (NEST). SHEET 2 OF 2. INDEX NOS. 54-102. SEE LIST 46.

TOOLS AND TEST

LIST AND INDEX NUMBER	PART NUMBER	DESCRIPTION				UNITS PER ASM.	USABLE ON CODE
		1	2	3	4		
46 - 54	5495343	. .	SWITCH			1	
- 55	438540	. .	SCREW, MACH, BH, 2-56 X 3/8 LG	ATT PT		4	
- 56	219549	. .	WASHER, LOCK, SPLIT, NO. 2 X 0.165 OD	ATT PT		4	
- 57	47987	. .	NUT, PLAIN, HEX, 2-56 X 3/16 FL W	ATT PT		4	
- 58	5495372	. .	CARD ASSEMBLY			1	
- 59	438550	. .	SCREW, MACH, BH, 4-40 X 1/2 LG	ATT PT		2	
- 60	232398	. .	WASHER	ATT PT		2	
- 61	212861E	. .	WASHER	ATT PT		2	
- 62	5495462	. .	CONNECTOR, 15 CONTACT			1	
- 63	236550	. .	SCREW, MACH, BH, 4-40 X 0.375 LG	ATT PT		2	
- 64	5495349	. .	RECTIFIER			1	
- 65	322065	. .	SCREW, MACH, BH, 6-32 X 5/8 LG	ATT PT		1	
- 66	344015	. .	NUT, SELF LOCK, HEX, 6-32 X 5/16 FL W	ATT PT		1	
- 67	2414892	. .	TRANSISTOR NPN, TYPE 257			1	
- 68	2414952	. .	TRANSISTOR, NPN, TYPE 266			2	
- 69	5495341	. .	SOCKET			3	
- 70	322065	. .	SCREW, MACH, BH, 6-32 X 5/8 LG	ATT PT		6	
- 71	5270517	. .	INSULATOR, MICA			3	
- 72	5495345	. .	COVER, SAFETY			1	
- 73	124943	. .	LABEL			1	
- 74	5495335	. .	TRANSFORMER			1	
- 75	332620	. .	SCREW, MACH, BH 10-32 X 1/2 LG	ATT PT		4	
- 76	9092	. .	WASHER, LOCK, SPLIT RING, 0.194ID 0.337O	ATT PT		4	
- 77	56079	. .	WASHER, LOCK, EXT TEETH, 0.195ID 0.410OD	ATT PT		4	
- 78	11598	. .	NUT, PLAIN, HEX, 10-32 X 3/8 FL W	ATT PT		4	
- 79	5495317	. .	COVER, SAFETY			1	
- 80	322550	. .	SCREW, MACH, BH, 6-32 X 1/2 LG	ATT PT		3	
- 81	257986	. .	WASHER, FLAT, NO. 6 X 0.312 OD	ATT PT		3	
- 82	5495381	. .	STANDOFF			3	
- 83	5495329	. .	CLAMP			1	
- 84	38376	. .	SCREW, MACH, FIL H, 8-32 X 1-1/4 LG	ATT PT		1	
- 85	1090873	. .	WASHER, LOCK, SPLIT RING, 0.168ID, 0.296OD	ATT PT		1	
- 86	208235	. .	CAPACITOR, ELECT, 5500MFD P 100 M 10%			1	
- 87	2181753	. .	CAPACITOR			1	
- 88	5495347	. .	CLAMP			1	
- 89	641	. .	SCREW, MACH, FIL H, 8-32 X 0.750 LG	ATT PT		1	
- 90	1090873	. .	WASHER, LOCK, SPLIT RING, 0.168ID, 0.296OD	ATT PT		1	
- 91	208245	. .	CAPACITOR, ELECT, 2500MFD P 100 M 10%			2	
- 92	5495328	. .	PLATE			1	
- 93	81693	. .	SCREW, MACH, BH, 6-32 X 3/8 LG	ATT PT		3	
- 94	6364	. .	WASHER, LOCK, SPLIT, NO. 6 X 1/4 OD	ATT PT		3	
- 95	5495330	. .	STANDOFF			3	
- 96	813179	. .	CLAMP, BOARD			2	
- 97	38354	. .	SCREW, MACH, FIL H, 6-32 X 1/2 LG	ATT PT		2	
- 98	5495349	. .	BOARD ASSEMBLY			1	
- 99	322550	. .	SCREW, MACH, BH, 6-32 X 1/2 LG	ATT PT		4	
-100	257986	. .	WASHER, FLAT, NO. 6 X 0.312 OD	ATT PT		4	
-101	251970	. .	SCREW, MACH, BS H, 4-40 X 0.250 LG			4	
-102	5495314	. .	PANEL			1	
-103	5495324	. .	CASE			1	





NUMERICAL INDEX

PART NO.	LIST AND INDEX NO.	PART NO.	LIST AND INDEX NO.	PART NO.	LIST AND INDEX NO.	PART NO.	LIST AND INDEX NO.
92	1 - 12	11598-CONT	5 - 83	38051-CONT	4 - 74	55901-CONT	35 - 42
194	1 - 47		12 - 6		23 - 4		35 - 52
288	18 - 17		16 - 4		23 - 29		39 - 65
337	17 - 103		16 - 43		36 - 16	56079	42 - 9
	23 - 17		17 - 79		36 - 50		6 - 26
443	3 - 59		23 - 10	38214	12 - 50		12 - 5
	17 - 47		23 - 35	38235	3 - 20		17 - 92
598	16 - 2		26 - 97		3 - 43		22 - 35
641	46 - 89		33 - 28B		4 - 20		23 - 11
845	26 - 100		46 - 19		4 - 72		23 - 36
1413	1 - 16		46 - 78		5 - 52		26 - 96
1668	1 - 7	11891	4 - 50		12 - 36		32 - 27
1942	3 - 34		4 - 57		12 - 39		46 - 77
2118	1 - 9	18491	1 - 23		12 - 60	56121	4 - 8
3550	29 - 61	18735	12 - 55		12 - 66		28 - 3
	29 - 61	19944	39 - 51		17 - 12	56722	5 - 42
3960	29 - 61	22478	5 - 24		23 - 32		12 - 37
5528	3 - 39		22 - 27		30 - 1		12 - 40
6318	3 - 40		29 - 29		45 - 3		12 - 53
6325	1 - 28		39 - 17	38263	21A- 68		12 - 61
6364	3 - 44	23096	29 - 15	38264	16 - 36		12 - 67
	3 - 49	24588	22 - 62		19 - 15		15 - 6
	3 - 53		22 - 69		33 - 36		17 - 13
	3 - 57	25282	22 - 12	38266	44 - 8		17 - 77
	22 - 30	25627	22 - 37		44 - 16		21A- 10
	22 - 61		29 - 23	38271	1 - 33		23 - 5
	22 - 68		35 - 41	38350	21A- 12		23 - 28
	23 - 24		35 - 51		21A- 14		23 - 33
	39 - 21		39 - 16		21A- 17		24 - 28
	39 - 27		39 - 64		21A- 20		24 - 48
	39 - 31	25672	21 - 10	38352	26 - 84		26 - 29
	45 - 22	26464	22 - 4	38354	13 - 67		27 - 28
	45 - 26	28413	4 - 12		20 - 78		35 - 37
	46 - 94		17 - 60		21 - 61		42 - 31
6444	28 - 26		17 - 91		26 - 35		42 - 65
7341	1 - 24	32042	5 - 28		27 - 22		45 - 28
8235	4 - 66		6 - 25		46 - 97	58207	4 - 30
8506	18 - 19		12 - 4	38363	1 - 31		5 - 21
	31 - 10		16 - 25		1 - 53		13 - 44
	38 - 29		46 - 5	38376	46 - 84		17 - 87
9092	3 - 60		46 - 7	38380	17 - 49		17 - 99
	16 - 3	32617	4 - 7		17 - 95		17 - 113
	35 - 64		17 - 54	38433	16 - 41		17 - 122
	46 - 18		26 - 95		26 - 52		20 - 43
	46 - 76	34512	6 - 8	38442	16 - 73		21 - 26
10170	3 - 56		6 - 18	45642	5 - 53		23 - 46
	4 - 23		11 - 20	45651	22 - 3		31 - 6
	5 - 41		12 - 44	45690	4 - 51		31 - 8
	5 - 56		22 - 6		5 - 29		31 - 30
	13 - 71		39 - 70		5 - 84		33 - 28
	17 - 17		45 - 47		16 - 55	59647	29 - 61
	17 - 57		45 - 58		17 - 61	59652	29 - 61
	19 - 11	35739	15 - 5		17 - 80	60646	3 - 19
	20 - 81		23 - 52		17 - 93		4 - 31
	21 - 64	37066	38 - 28		23 - 37		17 - 114
	21A- 2	37913	2 - 12		29 - 24		17 - 123
	21A- 9		2 - 15		32 - 28		35 - 25
	23 - 23		2 - 26		33 - 28D		39 - 53
	24 - 11		15 - 7	47242	4 - 9	62031	3 - 21
	27 - 8		21A- 69	47987	45 - 98		4 - 4
	27 - 17		25 - 18		45 - 100		4 - 21
	27 - 27		25 - 24		46 - 57		4 - 24
	29 - 28		26 - 54	49814	17 - 53		4 - 27
	29 - 37		30 - 6	52522	36 - 9		4 - 34
	31 - 16		30 - 43	55726	4 - 26		4 - 42
	35 - 2		33 - 37		4 - 79		4 - 67
	35 - 20		37 - 12		5 - 78		4 - 73
	35 - 27		38 - 34		16 - 13		4 - 80
	35 - 33		39 - 28		17 - 5		23 - 15
	35 - 48		39 - 39		17 - 76		26 - 36
	38 - 2		39 - 60		41 - 20		26 - 85
	38 - 58		41 - 9A	55901	6 - 9		45 - 6
	38 - 61		44 - 4		6 - 19		45 - 72
	39 - 24		44 - 9		6 - 29		46 - 15
	39 - 68		44 - 17		12 - 45	67873	26 - 20
	42 - 28		45 - 44		23 - 44	70078	13 - 42
	45 - 30		45 - 67		23 - 47		20 - 41
	45 - 61	38051	4 - 3		23 - 56		21 - 24
11598	4 - 10		4 - 33		26 - 101	72828	39 - 18
	5 - 30		4 - 41		33 - 28C	73134	29 - 43

TOOLS AND TEST

PART NO.	LIST AND INDEX NO.	PART NO.	LIST AND INDEX NO.	PART NO.	LIST AND INDEX NO.	PART NO.	LIST AND INDEX NO.
75449	35 - 63	129242	42 - 22	186759-CONT	29 - 5	210866	3 - 55
76521	46 - 22	129243	5 - 39		29 - 7	210867	3 - 68
78952	18 - 1	129244	5 - 38		29 - 11	210868	3 - 47
79779	4 - 60	133840	21A- 36		29 - 22	210870	3 - 66
80817	29 - 52	138754	39 - 79		29 - 46	210871	3 - 10
81693	15 - 3		45 - 37		29 - 57	210872	3 - 46
	17 - 4	138755	27 - 29		35 - 24	210873	4 - 5
	28 - 63	150209	25 - 17	186961	16 - 18	210874	4 - 28
	33 - 8		26 - 53	186962	39 - 41	210875	3 - 24
	38 - 24		30 - 5	186967	11 - 6	210883	17 - 119
	38 - 55		30 - 40		13 - 50		27 - 20
	39 - 26		44 - 3		22 - 75		35 - 21
	39 - 74	159297	3 - 58		30 - 22		39 - 68A
	39 - 76	159373	22 - 21		30 - 48	210884	17 - 118
	42 - 25		24 - 16	186988	1 - 3		27 - 21
	42 - 30		35 - 11	187243	5 - 5	210967	17 - 50
	42 - 49		39 - 6		5 - 32	210984	4 - 14
	45 - 21		39 - 9		5 - 67		17 - 89
	45 - 25		39 - 12		24 - 34		17 - 116
	45 - 50		39 - 15		42 - 13		29 - 48
	45 - 54		39 - 18		42 - 16	210985	29 - 53
	46 - 14		45 - 88		42 - 40	210986	29 - 54
	46 - 93		45 - 92	187459	1 - 48	212775	19 - 6
81779	13 - 78		45 - 109	187467	29 - 47	212822	14 - 5
81898	4 - 15		46 - 40	187470	17 - 88		19 - 4
91373	36 - 7	159944	5 - 47	187855	4 - 13		28 - 49
	38 - 27	165605	28 - 10	189136	13 - 76	213536	36 - 27
91514	1 - 54	167338	12 - 3		20 - 88		42 - 21
92748	3 - 9		45 - 53		21 - 71	213539	1 - 42
	39 - 62	169698	29 - 26		34 - 2	213556	7 - 4
92784	3 - 11	170589	1 - 22	189138	11 - 7	213693	8 - 1
	3 - 16	171092	44 - 22		13 - 74		9 - 1
	3 - 36	173937	29 - 9		20 - 84		10 - 1
	17 - 44	176106	26 - 11		21 - 67		16 - 60
	39 - 45	176325	29 - 44		34 - 1		31 - 33
94856	4 - 38	177946	3 - 50	191480	17 - 115		36 - 37
95834	35 - 46		17 - 69	195000	17 - 22	213714	1 - 38
97992	13 - 77	179007	26 - 93		36 - 4	214928	2 - 16
	20 - 89	179744	5 - 15	196722	1 - 14	214968	5 - 61
	21 - 72		5 - 17	198363	5 - 44		5 - 68
99174	45 - 74		5 - 60		5 - 48	215680	11 - 8
101922	35 - 50		30 - 24	198981	33 - 46	216075	28 - 51
	39 - 75	179946	18 - 2	198932	31 - 24	216076	13 - 69
103895	1 - 27		27 - 25	204362	12 - 11		14 - 6
105792	1 - 4		29 - 41	205331	5 - 34		19 - 8
107611	3 - 17		35 - 16		42 - 23		20 - 79
	3 - 23	180528	29 - 60	206046	1 - 50		21 - 62
	17 - 74		33 - 47	206047	1 - 50		23 - 26
	34 - 7	183720	29 - 56	206589	1 - 11	216083	14 - 7
	46 - 12	183848	29 - 2	206592	1 - 34		19 - 7
109918	39 - 34	183900	3 - 18	206593	1 - 25		28 - 50
110114	13 - 72		28 - 38	206595	1 - 40		31 - 35
	20 - 82		32 - 3	206913	1 - 20	216085	14 - 3
	21 - 65		32 - 12	206914	1 - 21		19 - 1
111256	23 - 48		32 - 24	206915	1 - 19		21A- 5
111259	45 - 16		33 - 2	206916	1 - 17		31 - 34
111264	29 - 40	186399	16 - 57	207316	4 - 77	216091	16 - 35
	35 - 15	186442	1 - 10	207324	4 - 75		19 - 14
	39 - 49	186444	1 - 30		23 - 7	216197	4 - 49
112628	39 - 31	186446	1 - 26	207348	4 - 19	216206	4 - 68
113692	29 - 8	186447	1 - 52	208224	17 - 97		14 - 2
115186	11 - 4	186448	1 - 15	208229	4 - 25		19 - 2
	12 - 8	186449	1 - 29		4 - 71		23 - 21
	12 - 10	186450	1 - 5	208235	46 - 86		33 - 26
	12 - 42	186451	1 - 55	208245	46 - 91	216208	16 - 46
	12 - 64	186452	1 - 49	208989	4 - 36		28 - 18
117184	24 - 17	186453	1 - 46	209314	5 - 40		32 - 17
117386	33 - 14	186454	1 - 45	209483	4 - 17		38 - 63
118418	1 - 44	186455	1 - 43	209484	4 - 16	216209	16 - 47
118463	11 - 9	186460	1 - 13A	209486	33 - 30		28 - 19
123072	26 - 67	186461	1 - 13B		33 - 41		31 - 20
	26 - 80	186478	1 - 13	209529	28 - 64		32 - 20
124580	21A- 32	186530	1 - 32	210839	3 - 29		38 - 66
124581	42 - 14	186586	26 - 3	210844	4 - 6	216210	16 - 50
124585	21A- 39	186636	1 - 6	210845	4 - 35		28 - 20
124589	30 - 11	186758	42 - 8	210846	3 - 26		31 - 19
124943	46 - 73	186759	6 - 2	210850	3 - 3		32 - 19
128455	3 - 27		6 - 6	210855	3 - 35		38 - 67
	3 - 61		23 - 43	210857	3 - 42	216215	21A- 15
	30 - 23		23 - 55	210860	3 - REF	216231	16 - 39

TOOLS AND TEST

PART NO.	LIST AND INDEX NO.	PART NO.	LIST AND INDEX NO.	PART NO.	LIST AND INDEX NO.	PART NO.	LIST AND INDEX NO.
216265	5 - 33 13 - 36 13 - 49 13 - 68 14 - 4 21 - 16 21 - 30 28 - 28 28 - 40 31 - 23 32 - 22	234058 234453 234457 236550	11 - 25 21 - 8 21A- 66K 5 - 36 22 - 9 22 - 45 22 - 51 27 - 3 28 - 17 32 - 18 38 - 64 39 - 37 46 - 63	257187-CONT 257189	45 - 35 45 - 52 45 - 56 3 - 41 6 - 10 6 - 20 6 - 28 12 - 46 13 - 45 20 - 44 21 - 27 22 - 26 25 - 12 26 - 102 29 - 25 35 - 43 35 - 53 39 - 52 39 - 66 39 - 71 42 - 10 45 - 48 45 - 59 30 - 49 1 - 18 29 - 31 16 - 10 12 - 49 15 - 16 15 - 22 38 - 33 39 - 27 39 - 38 46 - 36 5 - 87 15 - 15 15 - 21 36 - 19 46 - 35 5 - 57 17 - 18 17 - 58 17 - 64 22 - 31 23 - 25 27 - 32 36 - 15 36 - 49 38 - 20 46 - 81 46 - 100 6 - 14 8 - REF 5 - 43 42 - 24 12 - 30 6 - 15 9 - REF 6 - 16 10 - REF 10 - 7 8 - 7 9 - 4 10 - 8 8 - 8 9 - 5 10 - 9 8 - 2 10 - 2 13 - 53 20 - 56 21 - 43 8 - 3 8 - 4 10 - 3 7 - 6 10 - 4 7 - 5 12 - 18 8 - 5	300729-CONT 300734 300736 300793 301356 301416 301750 301768 301824 301825 301826 301881 302090 302131 303549 304994 306112 308704 309758 309900 309919 309920 309921 309922 309923 309929 309944 311546 312575 313289 313745 314047 315977 316807 316996 317004 317006 317008 317011 317012 317014 317016 317018	9 - 2 10 - 5 1 - 35 7 - 3 12 - 24 24 - 21 26 - 13 17 - 15 3 - 38 17 - 112 23 - 31 8 - 6 9 - 3 10 - 6 12 - 14 7 - 1 4 - 39 24 - 23 27 - 2 24 - 25 27 - 4 27 - 24 46 - 21 6 - 13 29 - 4 5 - 46 12 - 7 12 - 41 12 - 63 7 - 8 8 - 10 9 - 7 10 - 11 7 - 13 7 - 12 8 - 15 9 - 12 10 - 16 7 - 10 7 - 9 8 - 11 9 - 8 10 - 12 8 - 16 9 - 13 10 - 17 8 - 9 9 - 6 10 - 10 13 - 3 20 - 3 5 - 9 13 - 22 20 - 22 33 - 28A 3 - 33 42 - 17 43 - 6 4 - 54 4 - 58 17 - 81 23 - 12 23 - 40 21 - 45 21A- 44 30 - 12 20 - 55 1 - 36 16 - 58 4 - 76 20 - 57 21A- 31 20 - 52 21 - 42 13 - 55 16 - 62 20 - 53 21 - 37 21 - 44 21A- 26
216266	19 - 5						
216285	16 - 37 19 - 3	236849	16 - 8 16 - 54 16 - 75 21 - 6 21 - 14 21A- 66G 21A- 66N				
216286	5 - 79 21A- 6 28 - 47 32 - 13						
216300	5 - 7 17 - 21 28 - 14 33 - 43						
216304	5 - 8 17 - 23 28 - 15 33 - 44	236915 236916	24 - 39 22 - 53 24 - 35	257479 257570 257959 257982 257984			
216323	21A- 48 22 - 22 24 - 15 24 - 19 33 - 6 33 - 10 35 - 10 39 - 5 39 - 8 39 - 11 39 - 14 39 - 17 45 - 87 45 - 91 45 - 108 46 - 39	237322 240041 249080	1 - 8 22 - 32 13 - 30 13 - 39 20 - 30 20 - 39 21 - 21 11 - 3 46 - 32 13 - 19 20 - 19 2 - 2 2 - 11 2 - 14 15 - 14 17 - 85 30 - 39 45 - 43 46 - 10 46 - 101				
216337	3 - 63						
216338	3 - 28 3 - 62						
216339	3 - 8	252550	6 - 11	257986			
216340	3 - 6	253267	5 - 59				
216341	3 - 13	253453	24 - 49 25 - 29 45 - 40				
216428	16 - 63A						
216448	32 - 8						
216455	28 - 34	255522	29 - 42				
216482	38 - 47	256341	17 - 73	261159			
216499	2 - 21	257184	5 - 63	284424			
216735	2 - 23	257187	3 - 22				
216741	2 - 20			286533			
216746	2 - 22			300638			
216885	45 - 46			300642			
217019	4 - 52 17 - 82 21 - 36 21 - 38 217074 219423 219510 219549 219628 220032 220742 220856 221665 221790 5 - 20 5 - 23 5 - 26 30 - 13 13 - 8 20 - 8 23 - 41 29 - 59 46 - 60			300710 300712 300714 300720 300721 300722 300725 300727 300728 300729			

TOOLS AND TEST

PART NO.	LIST AND INDEX NO.	PART NO.	LIST AND INDEX NO.	PART NO.	LIST AND INDEX NO.	PART NO.	LIST AND INDEX NO.
317020	36 - 43	322551	36 - 48	338901	6 - 5	368169	26 - 50
317021	36 - 38	322552	38 - 19	338903	6 - 22		41 - 26
317023	36 - 28	322572	30 - 33		12 - REF	368199	39 - 12
317025	1 - 39		35 - 6	338904	6 - 17	369118	21A- 29
	12 - 16	322599	11 - 21		11 - REF	369207	35 - 65
317028	12 - 25	322609	11 - 22	338905	6 - 23	369214	4 - 56
	36 - 30	322729	16 - 59	338906	6 - 30		23 - 9
317029	12 - 17	322731	7 - 2	338907	6 - 1	369218	24 - 9
317030	12 - 13	322766	17 -117	338908	6 - 4	369594	28 - 68
317031	12 - 20	322821	12 - 27	338909	11 - 24		32 - 29
317037	1 - 41	322888	30 - 19	338910	12 - 70	369611	36 - 42
317060	12 - 22	323656	13 - 60	338911	12 - 65	369616	23 - 13
317065	12 - 23	323837	39 - 58	338912	6 - 21	369623	21A- 27
317142	36 - 21	323900	12 - 15	338913	12 - 47	369639	21 - 48
317145	45 - 32	323920	13 - 54	338914	12 - 43		21A- 38
317155	45 - 42	323925	23 - 8	338915	11 - 19	369679	36 - 40
317156	12 - 58	324948	13 - 23	338916	11 - 2	370066	13 - 64
317157	12 - 51		20 - 23	338917	12 - 9	370262	17 - 31
	12 - 56	324999	5 - 45	338920	12 - 1	370372	28 - 31
317173	11 - 1		42 - 26	338921	6 - 7		32 - 5
	18 - 3	325862	21A- 46	338926	11 - 26	370421	21A- 4
317200	12 - 59	327922	45 - 49	340001	6 - 27	370453	13 - 62
317218	12 - 57	328480	39 - 72	344015	24 - 44	370616	3 - 1
317232	23 - 51	331065	33 - 11		38 - 21	370805	21 - 56
	27 - 19		42 - 5		38 - 25		21A- 4
317262	12 - 31	331122	26 - 10		38 - 53	370860	21A- 4
317272	1 - 37	331698	11 - 10		38 - 56	371071	5 - 72
317276	36 - 32	332620	21 - 4		46 - 66	371078	5 - 76
317287	2 - 19		21A- 66F	344599	5 - 50	371079	5 - 73
317338	12 - 28		46 - 17	347181	18 - 14	371262	5 - 71
317339	12 - 33		46 - 75	348494	20 - 90	371265	5 - 70
317367	5 - 6	333264	12 - 12		21 - 74	371272	5 - 74
317421	21A- 60	334067	11 - 5	350384	44 - 1	371277	5 - 69
317430	20 - 58	334149	3 - 31	350422	20 - 66	371501	17 - 36
317485	35 - 35	334768	17 - 41	350432	20 - 61	371679	13 - 65
317520	12 - 69		17 - 71		21 - 34		20 - 76
317797	3 - 64		17 -107	350444	20 - 65		21 - 55
318324	36 - 25	334902	16 - 63C		21 - 39	371884	5 - 75
320167	42 - 20	334914	20 - 50	350447	20 - 64	371931	13 - 63
320456	17 - 98	334921	3 - 12	350475	20 - 62		20 - 75
320570	13 - 81		3 - 15		21 - 35	372006	17 - 30
	20 - 92		3 - 37	350977	45 - 29	372008	17 - 38
	21 - 75		17 - 42	351045	13 - 75	372009	17 - 34
	21A- 47		17 - 45		20 - 85	372010	17 - 35
	33 - 15		17 - 67		21 - 70	372016	17 - 33
	42 - 6		17 - 72	354167	24 - 20	372079	21 - 58
320610	16 - 63B		17 -108	354656	28 - 39		21A- 4
321019	12 - 26		18 - 13	356642	39 - 73	372080	21 - 59
321057	12 - 2		24 - 36	356742	39 - 29		21A- 4
321195	12 - 21		29 - 49	358844	24 - 18	372155	21A- 4
321271	36 - 26		30 - 46		43 - 4	372182	21A- 4
321397	16 - 26		39 - 46	359553	34 - 6	372610	17 - 37
322065	3 - 52		42 - 39	359695	16 - 15	372683	20 - 74
	35 - 36		45 - 38	360032	12 - 32		21 - 57
	36 - 14	334932	3 - 5	360193	28 - 6	372718	17 - 29
	45 - 33		13 - 35	360370	3 - 7	372737	17 - 32
	46 - 65		20 - 35		3 - 14	372826	17 - 24
	46 - 70		21 - 17	360433	24 - 38	373485	17 - 25
322235	12 - 34		21 - 31	360590	39 - 40	373486	17 - 26
322267	17 -120		22 - 74	360664	13 - 52	374133	17 - 28
322310	13 - 79		42 - 34	360882	39 - 50	374143	17 - 27
	20 - 91	336719	29 - 61	360902	13 - 56	374201	33 - 25B
	21 - 73	337549	23 - 18		20 - 49	374202	33 - 25D
	31 - 4	338106	6 - 12	361503	17 -110	374204	33 - 25C
322347	12 - 19		7 - REF	362193	45 - 36	374492	21A- 4
	20 - 51	338108	7 - 11	363420	5 - 14	374626	33 - 25A
322550	3 - 48	338110	7 - 7	365047	16 - 30	374818	23 - 19
	15 - 24	338159	11 - 23		18 - 8	374900	21A- 4
	21A- 64	338165	46 - 20		26 - 16	375068	21A- 4
	22 - 60	338169	15 - 6	365048	18 - 7	385951	38 - 30
	22 - 67		25 - 23	367115	35 - 22	396071	28 - 16
	23 - 14	338174	12 - 35		35 - 34A	419130	23 - 38
	37 - 4	338175	12 - 38	367182	33 - 9	424193	20 - 59
	38 - 52	338238	5 - 86	368164	18 - 9		21 - 32
	39 - 20		12 - 48		26 - 17	438008	21A- 33
	39 - 30		16 - 48	368168	18 - 11	438267	35 - 62
	39 - 68B		31 - 18		26 - 37	438540	46 - 55
	45 - 13		36 - 18		30 - 27	438548	16 - 34
	46 - 80		38 - 65		33 - 4		28 - 33
	46 - 99		46 - 34		36 - 3		32 - 7

TOOLS AND TEST

PART NO.	LIST AND INDEX NO.	PART NO.	LIST AND INDEX NO.	PART NO.	LIST AND INDEX NO.	PART NO.	LIST AND INDEX NO.
438548-CONT	41 - 9	461444	16 - 20	520409	42 - 18	591649-CONT	21A- 66A
	41 - 16	461445	16 - REF	520539	17 - 66	591746	13 - 17
438549	15 - 5	461446	16 - 56	521736	12 - 29		20 - 17
	39 - 26	472187	45 - 31	521737	3 - 32	591747	13 - 5
438550	2 - 25	473406	4 - 44		36 - 22		20 - 5
	15 - 20	473412	23 - 2	521829	33 - 7	591748	13 - 20
	39 - 59	473422	23 - 3	523176	13 - 32		20 - 20
	44 - 2	473426	4 - 32		20 - 32	591749	13 - 10
	45 - 66	473442	4 - 82	526378	4 - 1		20 - 10
	46 - 59		27 - 5		17 - 100	591750	13 - 14
438552	25 - 16		27 - 6		39 - 71A		20 - 14
438556	37 - 11	473531	4 - 61	527916	35 - 39	591752	16 - 52
438558	3 - 67	473533	4 - 81	528478	13 - 66		21 - 2
438559	30 - 4	473536	4 - 48		20 - 77		21A- 66D
438566	16 - 77	473543	4 - 40		21 - 60	591753	21 - 13
	17 - 7	473544	4 - 64		21A- 11		21A- 66L
438568	12 - 52	473576	4 - 2	528486	20 - 54	591754	21 - 5
438572	17 - 63	473582	4 - 53		21A- 30		21A- 66E
	21A- 24		17 - 83	528824	28 - 58	591755	21 - 3
438586	29 - 19		23 - 39	528937	16 - 61		21A- 66H
	39 - 15	474180	26 - 33		21 - 47	591765	21 - 15
438814	26 - 1	475134	5 - 64	528946	36 - 34		21A- 66P
440655	22 - 2	475465	17 - 14	532398	21A- 63	591766	21 - 7
441107	42 - 15	477203	4 - 65	532429	16 - 21		21A- 66M
441181	23 - 50	477252	4 - 29	532903	5 - 4	591769	21 - 12
441318	5 - 35	477280	3 - 2	533534	4 - 22		21A- 66J
441770	6 - 24		4 - REF		4 - 78	591774	21 - 9
442814	3 - 65	477283	4 - 47	534768	31 - 5	594282	13 - 29
443793	42 - 19	477284	4 - 11	535058	13 - 57		13 - 38
444151	22 - 13	477285	4 - 46		20 - 69		20 - 29
450692	45 - 112	477287	4 - 45		21 - 50		20 - 38
450842	1 - 51	477288	4 - 59	535964	16 - 14		21 - 20
450954	17 - 55	477289	4 - 83	538649	20 - 86	595359	28 - 35
451057	1 - 1	479038	21A- 37		21 - 69		32 - 9
451656	33 - 17	479087	36 - 41	539691	25 - 10	595720	24 - 32
451659	33 - 18	479094	21A- 42	550020	36 - 33		24 - 55
452394	17 - REF	479125	36 - 39	550501	30 - 21		26 - 41
452400	22 - REF	479128	17 - 9		30 - 47		26 - 47
453026	33 - 19	479318	43 - 1		33 - 31		26 - 64
453048	2 - REF	479319	5 - 16	550511	18 - 10		26 - 77
453596	46 - REF	479953	4 - 43		26 - 12		26 - 90
453599	45 - REF		23 - 6		30 - 26		42 - 37
453611	38 - REF	480535	22 - 17		33 - 3		42 - 42
453625	39 - REF	483074	30 - 14	551687	45 - 86		42 - 54
453649	45 - REF	483107	17 - 111	555049	24 - 10		42 - 59
454105	1 - REF	483316	30 - 15	556510	13 - 70		43 - 10
454183	13 - 73	483523	39 - 16	556519	13 - 58	595725	13 - 33
	20 - 83		43 - 3		20 - 70		20 - 33
	21 - 66	483531	43 - 2		21 - 51		22 - 55
460476	6 - REF	483677	46 - 13	556826	13 - 1		22 - 73
460628	46 - 16	483681	35 - 44	556851	13 - 83	595726	13 - 34
460660	39 - 7	484351	32 - 21	556855	28 - 41		20 - 34
461119	33 - 20	491226	21 - 40	556933	13 - 41		22 - 54
461142	13 - REF	491278	36 - 29		20 - 40		22 - 72
461159	33 - 21	491349	16 - 51		21 - 23	595978	31 - 22
461201	16 - 20		31 - 21	556934	13 - 43	596224	21A- 66B
461202	16 - 24		38 - 68		20 - 42	596255	17 - 20
461203	16 - 65	492403	20 - 63	556935	13 - 61		17 - 40
461204	16 - 5	492405	36 - 36		20 - 73		20 - 36
461205	16 - 38	492473	20 - 67		21 - 54		20 - 48
461206	16 - 45		21 - 41	556938	13 - 82		28 - 28
461207	16 - 44	492475	13 - 51	556940	13 - 31		28 - 42
461208	16 - 56	492493	36 - 35		13 - 40		31 - 32
461209	16 - 1	492540	20 - 60		20 - 31		33 - 33
461212	16 - 6		21 - 33		21 - 22		33 - 40
461214	16 - 53	492592	21 - 46	589715	23 - 53		33 - 45
461215	16 - 31	502479	16 - 63		27 - 23	597068	5 - 55
461217	16 - 78		21A- 43	591047	16 - 19	597300	3 - 51
461218	16 - 7	503592	31 - 3		33 - 32		17 - 68
461219	16 - 9	507446	29 - 55	591607	13 - 4	597575	13 - 15
461220	16 - 16	507851	39 - 54		20 - 4		20 - 15
461222	16 - REF	510352	5 - 10	591608	13 - 6	597578	13 - 16
461390	20 - REF	510379	23 - 27		20 - 6		20 - 16
461413	21 - REF	513668	5 - 22	591609	13 - 7	597987	4 - 18
461436	16 - 31		16 - 11		20 - 7	598041	13 - 37
461438	16 - 24	513669	16 - 12	591640	13 - 11		20 - 37
461439	16 - 65	514306	21A- 67		20 - 11		21 - 19
461440	16 - 44	515661	16 - 32	591641	13 - 12		21A- 66C
461441	16 - 45	516919	30 - 25		20 - 12	598234	13 - 25
461443	16 - 38	519061	3 - 25	591649	21 - 18		20 - 25

TOOLS AND TEST

PART NO.	LIST AND INDEX NO.	PART NO.	LIST AND INDEX NO.	PART NO.	LIST AND INDEX NO.	PART NO.	LIST AND INDEX NO.
598237	13 - 2	725349	21A- 50	741861	18 - 4	821067	22 - 33
	20 - 2	725543	32 - 25	741862	26 - 14		28 - 1
598238	13 - 26	725570	42 - 4	743033	17 - 1	821069	28 - 21
	20 - 26	725588	32 - 15	743046	28 - 29	821071	28 - 57
598240	13 - 24	725937	33 + 22	743047	28 - 29	821073	22 - 10
	20 - 24	726580	32 - 16	743048	28 - 29		28 - 56
598241	13 - 21	726581	32 - 15	743049	28 - 29	821098	28 - 45
	20 - 21	726582	32 - 15	743050	28 - 29	821099	28 - 13
598248	13 - 27	726583	32 - 15	750342	17 - 96	822650	18 - 16
	20 - 27	726584	32 - 15	760156	32 - 1	822653	18 - 20
598253	13 - 9	726585	32 - 15	765295	44 - 7	822654	17 - 19
	20 - 9	726586	32 - 15		44 - 15	822655	17 - 39
598256	13 - 28	726587	32 - 15	765654	30 - 9	822656	17 - 43
	20 - 28	726588	28 - 27	765665	30 - 8	822659	17 - 70
598479	17 - 78	727001	28 - 37	765748	24 - 13	822661	17 - 51
	23 - 34		32 - 11	801391	34 - 4	822670	18 - 6
598688	13 - 13	727002	32 - 23	802130	5 - 11	822671	17 - 62
	20 - 13	727003	32 - 4	803278	22 - 34	822675	18 - 12
	21 - 11	727004	32 - 31		28 - 2	822676	17 - 2
599274	45 - 34	727005	28 - 36	804109	35 - 49	822677	17 - 11
602603	35 - 45		32 - 10	804455	29 - 27		18 - REF
602626	33 - 13	727006	28 - 32	804715	38 - 45	822678	17 - 52
602628	33 - 12		32 - 6		44 - 5		19 - REF
612781	37 - 18	727007	32 - REF	811363	24 - 40	822679	19 - 13
612952	29 - 20	730175	4 - 63		39 - 7	822680	17 - 124
616201	29 - 10	730176	4 - 62	811364	15 - 10A	822681	17 - 16
616202	29 - 30	731037	22 - 36	811417	42 - 67	822682	18 - 21
616203	29 - 12	731626	24 - 47	811426	24 - 43A	822683	17 - 48
616204	29 - 18		28 - 5	811802	22 - 42	822684	17 - 46
616205	29 - 16		28 - 8		22 - 48	822685	17 - 94
616206	29 - 6		28 - 23		26 - 39	822686	19 - 12
616209	29 - 3		28 - 44		26 - 45	822687	17 - 75
616210	29 - 61		28 - 46		26 - 62	822688	17 - 59
616211	29 - 1		28 - 53		26 - 75	822689	17 - 86
616212	29 - 50		28 - 55		26 - 82	822690	19 - 10
616213	29 - 50		28 - 61		26 - 88	822691	19 - 9
616214	29 - 50		28 - 67		38 - 38	822692	17 - 56
619372	29 - 17		42 - 64		39 - 6	822693	19 - 16
619851	29 - 21	731627	24 - 43		43 - 8	822696	17 - 8
619853	29 - 14	734483	28 - 25	811804	24 - 56	822697	17 - 6
621325	29 - 45		41 - 2		37 - 6	822698	17 - 3
621446	17 - 102	734878	24 - 12		38 - 39	822699	17 - 106
627901	27 - 35	734879	21A- 53		42 - 35	822742	33 - 29
628308	29 - 32		33 - 5		42 - 51	822743	33 - 34
629576	17 - 105		46 - 37	812193	25 - 25	822744	33 - 34
629577	17 - 121	734960	26 - 7		25 - 30	822745	33 - 42
631810	45 - 15	734961	26 - 9	813179	35 - 29	822746	33 - 42
634475	39 - 63	734963	26 - 8		42 - 66	822747	33 - 42
634543	39 - 67	735435	18 - 15		46 - 96	822751	33 - 23
635491	29 - REF		39 - 10	813197	39 - 21	822752	33 - 24
719003	5 - 49	737616	21A- 52		41 - 17	822779	33 - 1
719778	13 - 80		21A- 54	813234	39 - 20	822780	33 - 49
	20 - 87	737806	17 - 109	813329	41 - 18	822781	33 - REF
	21 - 68	737858	27 - 13	813392	42 - 11	822785	33 - 27
722867	5 - 2	737914	33 - 35	813621	26 - 86	822813	33 - 16
723155	5 - 3	737915	33 - 38	813681	39 - 42	822884	33 - 25
724485	18 - 5	737916	14 - 8	813769	15 - 25	822928	28 - 29
724749	5 - 80		33 - 39		41 - 14	822949	28 - 27
724800	5 - 12	738825	39 - 13		41 - 27	824483	35 - 4
724802	5 - 19		45 - 90	813801	39 - 43	824486	2 - 5
724803	5 - 85	738826	22 - 19	813802	39 - 41		2 - 18
724804	5 - 82		24 - 14	813810	24 - 50		35 - 5
724805	5 - 65		39 - 4	814127	39 - 21A	835273	46 - 38
724806	5 - 77	738828	22 - 20	815151	39 - 24	838063	22 - 18
724807	5 - 25	740452	22 - 76	815934	38 - 71	845763	22 - 38
724808	5 - 18	740453	22 - 28	821050	28 - REF	846525	2 - 17
724809	5 - 13	740455	22 - 24	821051	28 - 70	846527	2 - 24
724810	5 - 88	740456	22 - 23	821052	28 - 7	846528	2 - 9
724811	5 - 58	740459	22 - 43	821053	28 - 12	846529	2 - 27
724812	5 - 81		22 - 49	821054	28 - 9	846530	2 - 28
724830	5 - REF	740460	22 - 39	821055	28 - 60	846531	2 - 13
724839	5 - 66	740461	22 - 47	821056	28 - 11	846532	2 - 10
724840	5 - 31	740463	22 - 1	821057	28 - 66	846533	2 - 1
724843	5 - 1	740464	22 - 11	821058	28 - 4	846534	2 - 3
725155	28 - 48	740576	22 - 59	821059	28 - 24	846548	2 - 4
	32 - 14		22 - 66	821060	28 - 22	846549	2 - 7
725347	21A- 49	741136	22 - 63	821063	28 - 43	846554	2 - 8
	35 - 7		22 - 70	821064	28 - 54	846555	2 - 6
725348	21A- 51	741137	22 - 64	821065	28 - 52	847110	35 - 3
	35 - 8		22 - 71	821066	28 - 62	847111	39 - 10

TOOLS AND TEST

PART NO.	LIST AND INDEX NO.	PART NO.	LIST AND INDEX NO.	PART NO.	LIST AND INDEX NO.	PART NO.	LIST AND INDEX NO.
856508	45 -106	2102571--CONT	10 - 15	2156234	37 - 14	2200014	24 - 1
1070160	33 - 48	2103073	5 - 37	2156235	37 - 13	2200054	25 - REF
1077739	13 - 18	2106333	17 - 10	2156236	37 - 5	2200180	37 - REF
	20 - 18	2108782	31 - 29	2156238	37 - 10	2204180	42 - REF
	29 - 13	2108783	31 - 25	2156239	37 - 9	2207420	37 - 8
1090622	45 - 51	2108785	31 - 7	2156260	37 - 1	2207421	42 - 1
	45 - 55	2108786	31 - 37	2156799	30 - 30	2207422	42 - 1A
1090873	17 -104	2108787	31 - 12	2156808	30 - 35	2207424	42 - 47
	22 - 7	2108788	31 - REF	2156809	30 - REF	2207427	42 - 1B
	46 - 85	2109434	31 - 2	2156822	30 - 34	2207428	42 - 32
	46 - 90		31 - 27	2156824	30 - 50	2207429	42 - 57
1091111	18 - 18	2109834	34 - 5	2161716	30 - 32	2207430	42 - 50
	31 - 11	2111232	30 - 10	2161717	30 - 2	2207432	42 - 7
1091434	36 - 51	2111258	8 - 12	2161719	30 - 29	2219090	42 - 68
1092019	30 - 18		9 - 9	2161725	30 - 31	2248047	37 - 2
1092125	28 - 59		10 - 13	2163765	30 - 20		35 - 40
1103744	16 - 49	2111680	31 - 36	2163768	30 - 16		45 - 57
1104137	23 - 49	2114108	5 - 27	2163769	30 - 3	2263591	43 - REF
	45 - 17	2114388	34 - 3	2178596	25 - 4	2263592	43 - 7
1105014	11 - 13	2114389	34 - 9	2178597	25 - 3	2263593	43 - 5
1105015	11 - 12	2114985	30 - 41	2180972	24 - 45	2263594	43 - 13
1105018	11 - 14	2122016	28 - 30	2180973	24 - 51	2414892	46 - 67
1105024	11 - 11	2122039	28 - 69		24 - 54	2414952	46 - 68
1105288	11 - 18		32 - 30		25 - 14	2414977	36 - 31
1105289	11 - 17	2122194	31 - 9		27 - 7	2502866	21A- 59
1105291	11 - 16	2122202	26 - 57	2181005	24 - 3	2502872	21A- 3
1105294	11 - 15		26 - 70		24 - 27	2504500	21A- 61
1106000	29 - 58		30 - 36		24 - 59	2504517	21A- 55
1106594	29 - 38		38 - 72		25 - 6	2513300	15 - REF
1115657	21A- 65		46 - 25		42 - 45	2513301	15 - 17
1124562	29 - 35	2122203	26 - 59		42 - 48	2513302	15 - 23
1124741	29 - 34		26 - 72	2181100	25 - 5	2513304	15 - 26
1124807	29 - 36		38 - 73	2181101	24 - 58	2513305	15 - 2
1124810	29 - 39		46 - 24		42 - 69	2513307	15 - 8
1127055	3 - 4	2122204	31 - 28	2181102	24 - 61	2513308	15 - 4
1127741	38 - 32	2122254	46 - 23	2181103	25 - 32	2513315	15 - 13
1132438	14 - 1	2122256	38 - 74	2181104	24 - 62	2513316	15 - 9
1132508	29 - 33		41 - 24	2181106	24 - 26	2513320	15 - 1
1132694	26 - 99	2122257	26 - 73		42 - 44	2513321	15 - 18
1133593	41 - 6	2122258	26 - 58	2181107	25 - 31	2513323	15 - 19
1138167	35 - 56		26 - 71	2181109	25 - 15	2513327	15 - 12
	37 - 19	2122259	22 - 57	2181110	24 - 42	2730086	27 - 1
	39 - 56		30 - 44	2181112	24 - 30	2730088	27 - 16
	43 - 12	2122261	22 - 56	2181113	24 - 53	2784399	27 - 37
1143227	39 - 57		30 - 45	2181114	25 - 13	5052546	26 - 55
1160977	46 - 31	2122337	26 - 98	2181115	25 - 21	5052547	26 - 38
1164582	41 - 4	2122471	26 - 60	2181116	25 - 27	5052656	26 -104
1175350	15 - 13	2122472	46 - 27	2181117	24 - 46	5052658	26 - 81
1269120	41 - 1	2122734	41 - 22		42 - 63	5052660	26 - 94
1272825	41 - REF		46 - 28	2181119	24 - 4	5052666	26 -103
1280969	41 - 19	2122735	46 - 29	2181129	25 - 2	5052667	26 - 19
1280970	41 - 15	2122837	30 - 38	2181132	25 - 1	5052668	26 - 32
1280972	41 - 3	2122839	26 - 51	2181133	24 - 60	5052670	26 - 26
1280973	41 - 28		30 - 42		42 - 46	5052674	26 - 30
1280974	41 - 21	2123282	31 - 17	2181141	42 - 70	5052676	26 - 31
1280975	41 - 7	2123354	35 - 30	2181601	31 - 31	5052681	26 - 27
1280976	41 - 8	2123397	31 - 15	2181753	46 - 87	5052684	26 - REF
1280982	41 - 5	2127864	26 - 74	2191846	24 - 24	5052685	26 - 68
1280985	41 - 25		38 - 77	2192885	31 - 1	5052723	26 - 44
1765342	15 - REF	2127890	22 - 58		31 - 26	5052978	26 - 83
1765352	15 - 1		22 - 65	2194019	27 - 15	5052981	26 - 34
1765360	15 - 2		41 - 23		27 - 31	5052994	26 - 23
1765361	15 - 26	2127894	26 - 61	2197811	26 - 87	5052995	26 - 24
2100317	34 - 8	2127985	46 - 26	2197812	26 - 87	5052996	26 - 25
2100937	34 - REF	2127986	30 - 37	2197813	26 - 87	5115398	30 - 28
2101326	4 - 37	2127988	26 - 56	2197814	26 - 87	5150384	27 - 18
2101389	39 - 68C		26 - 69	2197815	26 - 87	5162745	35 - 66
2101495	30 - 17		38 - 75	2197864	26 - 5	5182427	27 - 10
2102096	7 - 9A	2127989	38 - 76	2197865	26 - 4	5182432	27 - 39
	8 - 13		46 - 30	2197917	26 - 21	5182438	27 - 36
	9 - 10	2128618	46 - 61	2197918	26 - 6	5182440	27 - REF
	10 - 14	2145077	30 - 7	2197989	26 - 42	5182448	27 - 9
2102364	31 - 14	2152826	42 - 21A		26 - 48	5182459	27 - 34
	42 - 61	2155702	45 - 80		26 - 65	5182482	27 - 30
2102365	5 - 51	2156228	37 - 20		26 - 78	5182544	27 - 7
	5 - 62	2156229	37 - 21		26 - 91	5182545	27 - 14
	31 - 13	2156230	37 - 3	2198227	26 - 22	5182546	27 - 38
2102367	22 - 25	2156231	37 - 15	2198862	26 - 18	5183588	27 - 26
2102571	8 - 14	2156232	37 - 16	2200012	24 - REF	5213122	42 - 27
	9 - 11	2156233	37 - 17	2200013	24 - 2	5213276	36 - 47

TOOLS AND TEST

PART NO.	LIST AND INDEX NO.	PART NO.	LIST AND INDEX NO.	PART NO.	LIST AND INDEX NO.	PART NO.	LIST AND INDEX NO.
5213296	39 - 47	5353887-CONT	39 - 9	5442687-CONT	39 - 55	5495073	38 - 59
5240455	17 - 90		39 - 22		45 - 73	5495077	38 - 57
5240458	17 - 101		42 - 3	5442722	38 - 78	5495078	38 - 60
5240459	17 - 84		45 - 83	5442723	38 - 35	5495085	38 - 46
5261089	23 - 30	5353888	46 - 44	5442725	38 - 36	5495134	39 - 44
5266079	23 - 20	5353889	22 - 15	5442726	38 - 4	5495138	35 - 17
5270517	46 - 71		24 - 6	5442727	38 - 18	5495140	35 - 67
5271723	44 - 11		25 - 8	5442730	38 - 54	5495141	35 - 34
	44 - 19		35 - 13	5442731	38 - 1	5495301	46 - 4
5271724	44 - 12		39 - 8	5442734	38 - 17	5495306	46 - 47
	44 - 20	5353890	35 - 12	5442735	38 - 13	5495314	46 - 102
5275481	38 - 41	5353902	39 - 35		38 - 16	5495315	46 - 6
	38 - 48	5353922	26 - 40	5442736	38 - 8	5495317	46 - 79
	39 - 25		26 - 46	5442737	38 - 37	5495318	46 - 8
	39 - 36		26 - 63	5442741	38 - 51	5495319	46 - 64
	39 - 46		26 - 76	5442742	38 - 40	5495321	46 - 11
5275486	38 - 42		26 - 89	5442743	38 - 40	5495324	46 - 103
	38 - 49	5356046	21 - 77	5442744	38 - 40	5495326	46 - 50
	39 - 37	5356048	21 - 63	5442745	38 - 22	5495327	46 - 45
	39 - 47	5356051	21 - 28	5442746	38 - 40	5495328	46 - 92
5302396	38 - 31	5356052	21 - 29	5442747	38 - 40	5495329	46 - 83
5302662	44 - 10	5356053	21 - 1	5442748	38 - 40	5495330	46 - 95
5302663	44 - 18	5356054	21 - 25	5442749	38 - 44	5495331	46 - 33
5312162	16 - 71	5356057	16 - 52	5442750	38 - 40	5495333	46 - 53
5312164	16 - 72	5356166	39 - 36	5442751	38 - 40	5495334	46 - 52
5312165	16 - 68	5356322	21A- 34	5442752	38 - 40	5495335	46 - 74
5312166	16 - 67		21A- 40	5442753	38 - 40	5495336	46 - 48
5312167	16 - 70		21A- 45	5442755	38 - 62	5495338	46 - 51
5312168	16 - 76	5362301	22 - 40	5442756	38 - 70	5495341	46 - 69
5312169	16 - 28		24 - 37	5442765	38 - 23	5495343	46 - 54
5312170	16 - 64		39 - 35	5442798	38 - 3	5495345	46 - 72
5312175	16 - 66		42 - 33	5442807	38 - 12	5495347	46 - 88
5312176	16 - 27		45 - 84	5442808	38 - 15	5495349	46 - 98
5312180	16 - 17	5362303	39 - 32	5442809	38 - 9	5495372	46 - 58
5312181	16 - 40	5362305	39 - 29		38 - 11	5495378	46 - 9
5312182	16 - 74	5362323	38 - 5		38 - 14	5495381	46 - 82
5312183	16 - 42		45 - 82		46 - 49	5495383	46 - 46
5312190	16 - 69		46 - 42	5442810	14 - 9	5495406	45 - 7
5312193	16 - 29	5362324	46 - 43	5442812	39 - 23	5495431	45 - 111
5312194	16 - 22	5362325	38 - 6	5442813	39 - 2	5495433	45 - 113
5312196	16 - 23	5363669	21 - 76	5442814	39 - 5	5495434	45 - 62
5312299	16 - 33	5364151	39 - 61	5442815	39 - 4	5495437	45 - 63
5314195	28 - 41	5367846	16 - 67	5442818	39 - 33	5495440	45 - 64
5319854	25 - 11	5367909	21A- 7	5442819	39 - 45		45 - 64
5323472	13 - 46	5372182	39 - 2	5442823	39 - 19	5495443	45 - 60
	20 - 45	5372183	39 - 3	5442847	39 - 23	5495444	45 - 1
5323473	13 - 47	5376712	46 - 41	5442848	39 - 80	5495445	45 - 10
	20 - 46	5404468	39 - 30	5442849	39 - 39	5495446	45 - 70
5323474	13 - 48	5404480	22 - 41	5442850	39 - 49	5495447	45 - 19
5342470	28 - 41		39 - 34	5442852	39 - 69	5495448	45 - 5
5344918	20 - 94		45 - 85	5442853	39 - 13		45 - 71
5344922	20 - 68	5418051	45 - 18	5442855	39 - 1	5495450	45 - 39
	21 - 49		45 - 41	5442856	39 - 25	5495453	45 - 110
5344923	20 - 47	5419461	21A- 62	5442857	39 - 40	5495454	45 - 45
5344924	20 - 1	5419462	21A- 62	5442858	39 - 78	5495455	45 - 76
5344925	20 - 80	5420330	21A- REF	5442859	39 - 77	5495456	45 - 94
5344926	20 - 72	5420331	21A- 70	5442863	39 - 1	5495457	45 - 104
	21 - 53	5420332	21A- 1	5442864	39 - 14A	5495458	45 - 99
5344927	20 - 93	5420333	21A- 23	5442865	39 - 19	5495459	45 - 95
5349203	39 - 11	5420334	21A- 35	5442866	39 - 42	5495460	45 - 93
5352308	39 - 48	5420335	21A- 41	5442923	39 - 14	5495461	45 - 105
5352958	22 - 44	5420336	21A- 8	5442995	39 - 3	5495462	45 - 65
	22 - 50	5420337	21A- 66	5443015	39 - 44		46 - 62
	43 - 9	5420338	21A- 19	5443016	39 - 43	5495463	45 - 107
5352960	24 - 31	5420339	21A- 16	5495038	46 - 1	5495464	45 - 9
	24 - 54	5420340	21A- 13	5495039	35 - 31	5495465	45 - 24
	42 - 36	5420341	21A- 22	5495040	35 - 68	5495466	45 - 20
	42 - 41	5420344	21A- 62	5495041	35 - 1	5495467	45 - 75
	42 - 52	5420346	21A- 18	5495042	35 - 32	5495468	45 - 77
5352967	42 - 53	5420347	21A- 21	5495043	35 - 26	5495469	45 - 78
	42 - 58	5420348	21A- 56	5495044	35 - 47	5495471	45 - 79
5353868	39 - 33	5420349	21A- 58	5495045	35 - 28	5495472	45 - 89
5353883	24 - 5	5420350	21A- 57	5495046	35 - 54	5495477	45 - 78
	25 - 7	5440649	35 - 60	5495047	35 - 55	5495478	45 - 78
	42 - 2	5440650	35 - 59		35 - 61	5495479	45 - 78
5353887	22 - 16	5442606	45 - 2	5495049	35 - 23	5495480	45 - 78
	24 - 7	5442608	45 - 101	5495059	44 - 14	5495481	45 - 11
	25 - 9	5442609	45 - 102	5495060	44 - REF	5495482	45 - 12
	35 - 14	5442687	35 - 57	5495061	44 - 23	5495483	45 - 8
	38 - 7		35 - 58	5495062	44 - 6	5495484	45 - 8



TOOLS AND TEST

PART NO.	LIST AND INDEX NO.	PART NO.	LIST AND INDEX NO.	PART NO.	LIST AND INDEX NO.	PART NO.	LIST AND INDEX NO.
5495485	45 - 81	5804663	24 - 41				
5495532	45 - 97	5808281	15 - 10				
5495534	45 - 68	5808301	15 - 11				
5495535	45 - 69	5811497	22 - 8				
5495537	45 - 96	5819436	24 - 57				
5500734	45 - 62		42 - 38				
5500735	45 - 63		42 - 55				
5500767	45 -103	5820448	27 - 11				
5500777	35 - 9	8022411	27 - 12				
5500788	35 - 19	8216712	15 - 10				
5700484	24 - 52	9900385	14 - REF				
	25 - 22	9900432	38 - 10				
	25 - 28						
	42 - 62						
5703843	44 - 13						
	44 - 21						
5708684	38 - 26						
5708689	38 - 69						
5708949	23 - 1						
5708951	23 - 45						
5708952	23 - 16						
5708953	23 - 42						
5708954	23 - 54						
5708955	22 - 5						
	23 - REF						
5708956	23 - 57						
5708957	23 - 22						
5709247	36 - 44						
5712439	36 - REF						
5712440	36 - 53						
5712441	36 - 6						
5712442	36 - 8						
5712443	36 - 20						
5712445	36 - 5						
5712446	36 - 44A						
5712447	36 - 45						
5712451	36 - 1						
5712452	36 - 10						
5712453	36 - 23						
5712454	36 - 11						
5712455	36 - 12						
5712456	36 - 46						
5712461	36 - 2						
5712463	36 - 52						
5712469	36 - 13						
5800000	24 - 41						
5800099	24 - 41						
5800236	24 - 41						
5800247	24 - 41						
5800346	24 - 41						
5800347	24 - 41						
5800509	24 - 41						
5800610	24 - 33						
	26 - 43						
	26 - 49						
	26 - 66						
	26 - 79						
	26 - 92						
5800634	22 - 46						
	22 - 52						
	25 - 19						
	38 - 43						
	38 - 50						
	39 - 38						
	39 - 48						
	42 - 43						
	42 - 56						
	42 - 60						
5800703	24 - 41						
5800725	24 - 41						
5800731	43 - 11						
5800869	24 - 41						
5800885	41 - 13						
5801216	25 - 20						
5801245	25 - 26						
5801333	41 - 10						
5801334	41 - 11						
5801335	41 - 12						
5802144	15 - 9						
5804018	24 - 41						





**YOUR COMMENTS, PLEASE . . .**

Your answers to the questions on the back of this form, together with your comments, help us produce better publications for your use. Each reply is carefully reviewed by the persons responsible for writing and publishing this material. All comments and suggestions become the property of IBM.

Please note: Requests for copies of publications and for assistance in using your IBM system should be directed to your IBM representative or to the IBM sales office serving your locality.

Cut Along Line

Fold

Fold

FIRST CLASS  
PERMIT NO. 569  
RESEARCH TRIANGLE PARK  
NORTH CAROLINA

**BUSINESS REPLY MAIL**  
NO POSTAGE STAMP NECESSARY IF MAILED IN U. S. A.

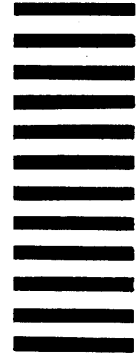

POSTAGE WILL BE PAID BY . . .

IBM Corporation  
P. O. Box 12275  
Research Triangle Park  
North Carolina 27709

Attention: Publications Center, Dept. E01

Fold

Fold

10015 AND 1 est Equipment Volume II (FC) Printed in U.S.A. S123-0438-3



**International Business Machines Corporation**  
**Data Processing Division**  
**1133 Westchester Avenue, White Plains, New York 10604**  
**(U.S.A. only)**

**IBM World Trade Corporation**  
**821 United Nations Plaza, New York, New York 10017**  
**(International)**



Tools/Test

Tools/Test

Fold

Cut

S123-0438-3

Tools and Test Equipment Volume 2 (PC) Printed in U.S.A. S\*23-0438-3

**IBM**

**International Business Machines Corporation  
Data Processing Division  
1133 Westchester Avenue, White Plains, New York 10604  
(U.S.A. only)**

**IBM World Trade Corporation  
821 United Nations Plaza, New York, New York 10017  
(International)**